



PROMATION ENGINEERING

Precision Actuation for Industry

Installation & Operation Manual

This IOM is for the following
ProMation Engineering Products:

P2-120PN4-I135

P3-120PN4 -I135





PROMATION ENGINEERING

Precision Actuation for Industry

Field Manual P2/3 120PN4-I135

0-135 ohm Proportional Control
ISO5211 F07 8P22



Table of Contents

2	Product Specifications
3	Shipping and Handling
3	Product Mounting and Setup
3	Installation Notes
4	Wiring Diagram
5	Diagram of Controller
6	Controller: Initial Startup
6	Controller: Change INPUT/OUTPUT signal type
7	Controller: Adjusting the actuator CW position
8	Cams: Adjusting the actuator CW position
9	Controller: Adjusting the actuator CCW position
10	Cams: Adjusting the actuator CCW position
11	Controller: Change Loss of Signal Response Setting
12	Controller: Auto-Calibration Procedure
13	Cams: Adjusting the actuator Auxiliary Switches
13	Commissioning
14	Mechanical Data
15	Mechanical Data

FM15_P23 HV PN4-I135 Ver A 091015

Product Specifications

Actuator Specifications	P2	P3
Torque "lb/Nm	800"lbs/90Nm	1335"lbs/150Nm
Supply Voltage	120vac	120vac
Max Inrush Current	1.8A	1.8A
Running Current	1.0A	1.2A
Motor	Split Phase Capacitor	
Runtime (90°@60Hz/vdc)	15 sec	22 sec
Runtime (90°@50Hz)	17 sec	26 sec
Duty Cycle	Proportional: Managed (75% maximum)	
Motor Starts	1200 per hour	
Weight	31lbs/14kg	
Mechanical Connections	ISO5211 F07 8pt 22mm	
Electrical Entry	(2) 3/4" NPT	
Electrical Terminations	12-18ga	
Environmental Rating	NEMA 4/4X	
Manual Override	5" Handwheel	
Control	Proportional (0-135 ohm)	
Actuator Case Material	Aluminum Alloy, Powder coated	
Motor Protection	230°F/110°C Thermal F* Class *Totally Enclosed Non-Ventilated Motors	
Ambient Temperature Operating Range	-22°F to +125°F -30°C to +52°C	

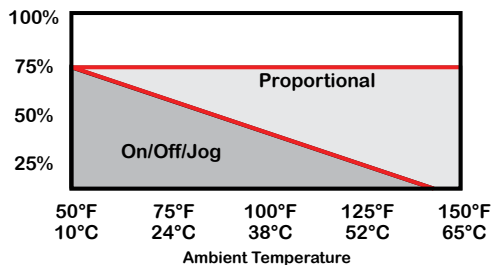

Introduction

This document provides necessary information for set-up, calibration, testing and use of the P Series quarter-turn electric actuators stated on the cover page. Each unit is shipped from the factory with initial calibration of mechanical stops, cams and switches completed for 0-90 degree operation. However, these are general settings and serve as a starting point for proper calibration of the actuator in its real-world application.

Safety

Safety is a basic factor any time you maintain and operate mechanical equipment. Appropriate handling methods and proper use of tools and clothes can help prevent serious accidents -- accidents which can cause injuries to you or a fellow worker. This manual was created to enable a trained user to install, adjust and troubleshoot your ProMation actuator.

Only competent and trained personnel should install, maintain and operate ProMation Actuators. Any work related to this actuator must be carried out in accordance with this manual and related codes and regulations. Local workplace health and safety rules should always be followed.

Duty cycle

Duty cycle is the percent of time that an actuator spends running as a fraction of the total time. Duty Cycle is directly related to heat; excessively repositioning an actuator typically results in motor overheating which can cause permanent damage and/or reduced service life.

Duty cycle can be calculated as follows:

(example P2 series actuator running 3 seconds ON and 30 seconds OFF)

Runtime = 3s, Total time = 3s + 30s = 33s, therefore this duty cycle would be 9% (3/33)

Additionally, ProMation P series actuators are designed for a maximum of 1200 starts per hour (one start every 3 seconds maximum).

Shipping and Handling

1. This actuator is shipped in the FULLY CW position (2 color position indicator shows "CLOSE" and the Reference Dimple aligns with "0"). (The "1" mark is the FULLY CCW position).
2. **NOTE, THIS ACTUATOR MUST HAVE WATER TIGHT EMT FITTINGS, WITH CONDUIT DRAINAGE INSTALLED AND POWER SUPPLIED TO UNIT TO KEEP THE HEATER WARM AT THE TIME OF INSTALLATION.**
3. **Storage: This unit should NOT be stored outside unless it is powered up and has proper conduit terminations. When NOT powered up, it should be stored in a clean, dry environment at all times.**
4. This actuator has been **factory calibrated to operate between 0 degrees and 90 degrees. Most quarter-turn products will not require recalibration of these settings.** If any travel adjustment is necessary, please refer to pages 7-13 for instructions.

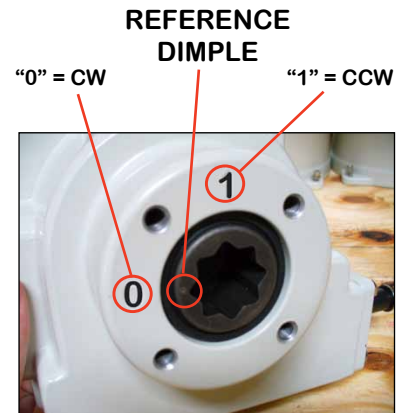

0 and 1 colored for clarity

5. **The actuator CANNOT operate with a rotation greater than 95 degrees.**

Product Mounting and Setup

1. Fully CLOSE the valve or damper to which the actuator is to be mounted.
 - Keep in mind this actuator rotates CW (as viewed from above the unit) when driving CLOSED.
2. Assemble necessary linkage components and attach the actuator to the driven device.
3. Tighten mounting bolts, making sure actuator is centered on the device drive shaft.
4. Utilize the handwheel to check for unobstructed manual operation from fully CCW to fully CW positions BEFORE applying power to the unit.
5. Make the electrical connections per wiring diagram on page 4.
 - Connect POWER to terminals marked H and N.
 - Actuator accepts a 0-135 ohm signal.
 - Connect CONTROL wires to terminals marked R, W, and G. The potentiometer wiper MUST connect to W or the controller will not function.
 - Wires for 4-20mA ONLY feedback may be connected to terminals – (OUT–) and + (OUT+) for remote position indication.
 - Terminals 7-12 on the switch card (430-10100) are for the (adjustable) aux switches. They are dry type Form C rated 10A @ 250vac MAX.
 - The drain wire on the signal cables must be grounded at ONE END ONLY! (Preferably at the supply end).
6. Do NOT apply power at this time.

Installation Notes

- These actuators are designed to be used between a horizontal and upright position. Do NOT mount the assembly with the actuator top below a horizontal position.
- When installing conduit, use proper techniques for entry into the actuator. Use drip loops to prevent conduit condensate from entering the actuator.
- Mechanical travel stops are factory calibrated for 90 degree operation. These stops are NOT designed to adjust mechanical rotation by more than +/- 3 degrees, they are for positioning the handwheel only.
- Both NPT conduit ports MUST use proper equipment to protect the NEMA 4X integrity of the housing.
- The internal heater is to be used in ALL applications.
- Do NOT install the actuator outdoors or in humid environments unless it is powered up and the heater is functioning.
- Use proper wire size to prevent actuator failure (see chart on page 4 for proper wire sizing).
- All terminals accept 12-16AWG solid/stranded wire.

Wiring Diagram

Proportional Control

Actuator ships in fully closed position!

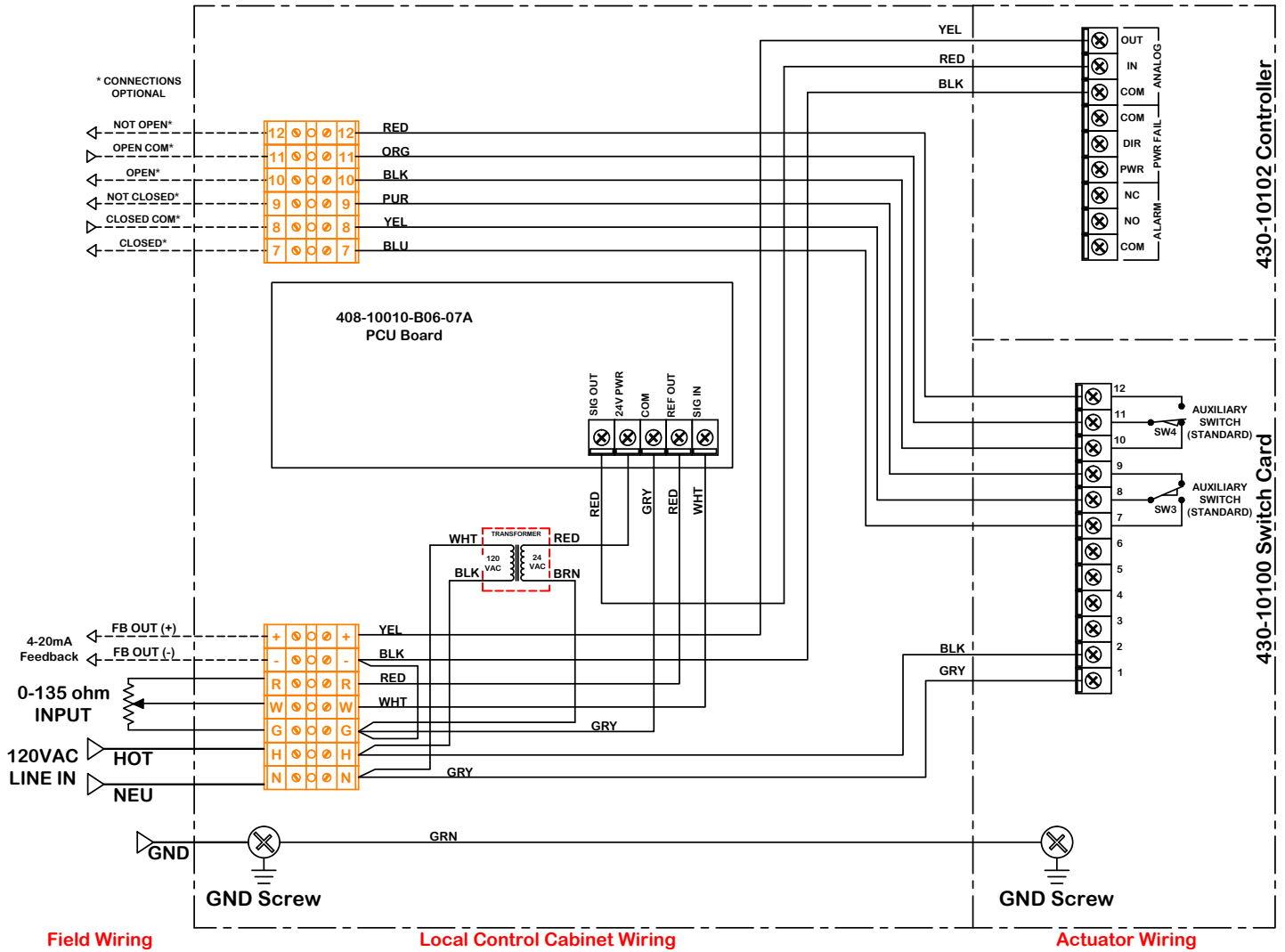

FM15_P23 HV PN4-I135 Ver A 091015

Wire Sizing Chart

MAX distance between Actuator and Supply (feet)		
Actuator/Voltage	P2 120VAC	P3 120VAC
Wire Gage / Amps	1.8A	1.8A
16	722	722
14	1166	1166
12	1783	1783
10	3030	3030
8	4523	4523

Wire sizing data is provided in the table to assist in the selection of the proper wire size for ProMotion actuators using various wire sizes over distance. Please make sure to reference the correct voltage and do not exceed the indicated length of the wire run for each model.

Diagram of Controller

Proportional Control

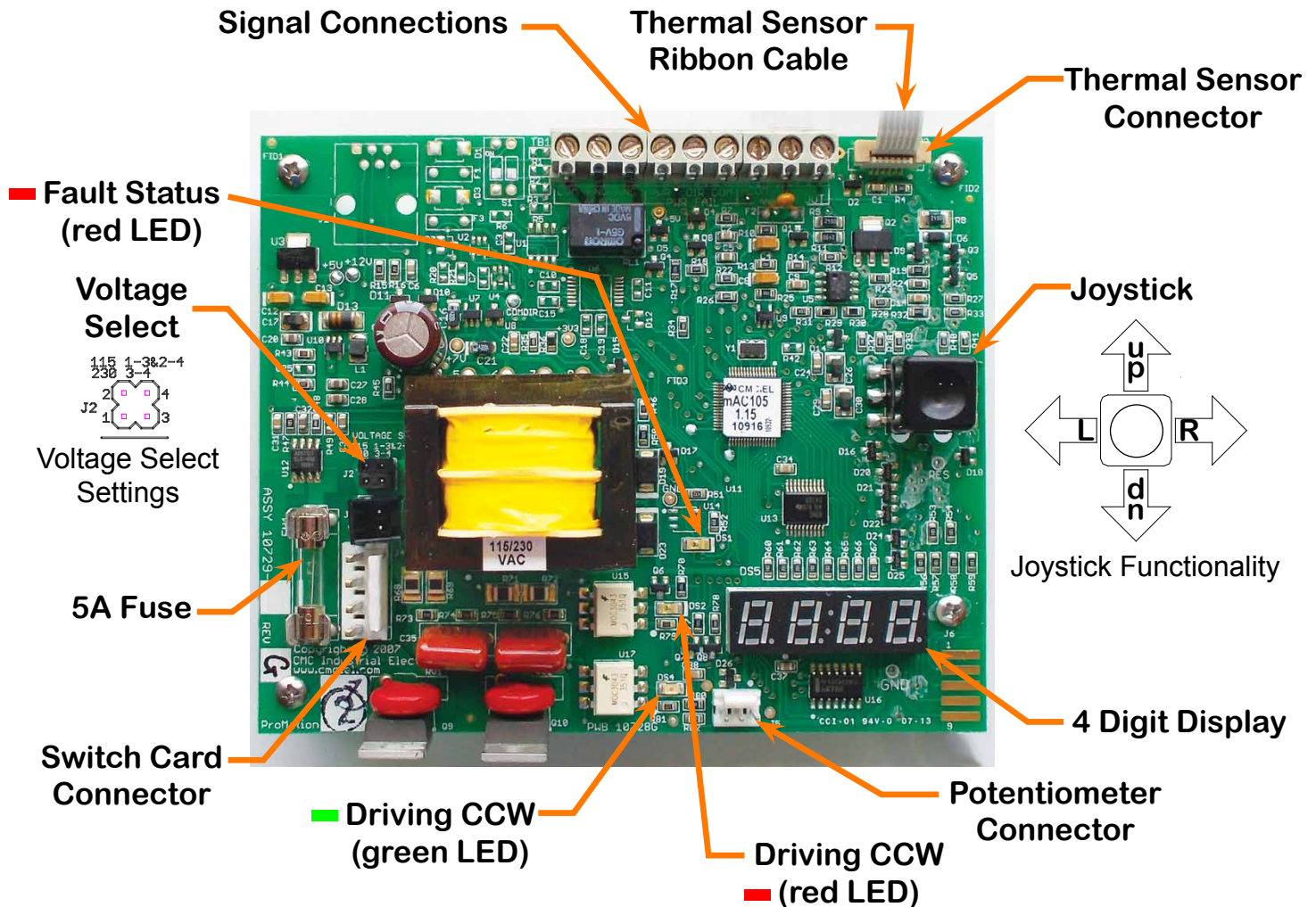

The proportional control card has been calibrated and tested at the factory to operate between 0 degrees and 90 degrees operating range. There is normally no need for any adjustments at this point in the installation. Changes from the factory set cam settings and controller settings can be very difficult to reverse.

The default settings in the controller are as follows:

- Input/Output Signal: 4-20mA ONLY (**Must not change this setting**)
- Signal Response: Direct Acting (max signal = CCW)
- Loss of Signal: Fail in Position
- Controller version: 1.15

The **Fault Status** indicator will blink once per second under normal operating conditions. It will blink approximately three times per second if a fault has occurred. A fault status indication will not return to normal unless the fault has been cleared or the board has been powered down.





Under normal operation, the **4 digit display** will show percentage of CCW position...i.e. 25 = 25% CCW, or roughly 22 degrees CCW.



Controller: Initial Startup

These instructions illustrate the initial power up sequence for power up, initial data displays, and position display so the user has a baseline for proper startup sequencing.

(Assumes actuator is properly mounted and wired as directed elsewhere in this manual).

Power Up (<i>baseline of normal functionality</i>):	4 digit display reads:	How the display behaves	Notes
1. Apply power to the actuator and wait 20 seconds for the controller to power up, self-test, and stabilize.		(Blank display before power up)	Power off
2. Immediately on power up the fault status light will begin blinking at a rate of once per second throughout operation		(Static display for about 1 second)	Initial power on display test of all led elements
3. The 4 digit display will begin sequencing through the self-test messaging.		(Text 'crawls' left to right. Displays twice.)	Software version (in this example: Version 1.15)
4. Because there are only 4 display characters the text will scroll or crawl across the display.	 example display	(Text 'crawls' left to right. Displays twice.)	Actuator - Voltage (in this example: P2 Actuator - 120 volt)
5. At this point the actuator is functioning properly.		(Static display, stays on.)	Rotation display showing 0.0% CCW
6. Note: Autocalibrating AFTER any controller modifications wipes out those modifications and the controller starts from it's new zero point.			

Controller: Adjusting the actuator CW position

Follow these instructions to adjust the CW position controlled by the 105 Proportional Controller (standard operation). Proceed to the next page to adjust the CW position controlled by the travel cam.

(Assumes actuator is powered up, running and is at the default display, showing position).

Press the joystick LEFT twice...	Display reads:	rEdLt, NE
Press the joystick DOWN three times...	Display reads:	SEt tRdUeL
Press the joystick RIGHT once...	Display reads:	AutO SEt
Press the joystick DOWN once...	Display reads:	FULL CLoSEd
Press the joystick RIGHT once... (actual position in steps)	Display reads:	00 to 4096

Press joystick UP and HOLD to drive further CCW or press DOWN and HOLD to drive further CLOSED. The adjusted CLOSED position MUST be between 50 and 1000 steps.

When the correct CLOSED position is established, press the joystick IN...	Display reads:	done
Press the joystick LEFT twice...	Display reads:	SEt tRdUeL
Press the joystick UP three times	Display reads:	rEdLt, NE
Press the joystick RIGHT once... DOWN twice, then RIGHT once, the display will now show % of CCW position (0.0 = Fully CW)		00 to 100

Notice! Performing an Auto Calibration after this procedure will ERASE this custom stop set point and will return to the factory default setting. For this reason, you CANNOT run an Auto Calibration procedure at any time after this setting has been changed.

Cams: Adjusting the actuator CW position

Serious Damage to the actuator will result if the motor is allowed to drive the gear train into the mechanical stop!! Remove power from this device BEFORE making any travel adjustments.

This actuator has been factory calibrated to operate between 0 degrees and 90 degrees. Most quarter-turn products will not require recalibration of these settings. Proceed **ONLY** if adjustments are required.



CW Mechanical Stop



Cam 1

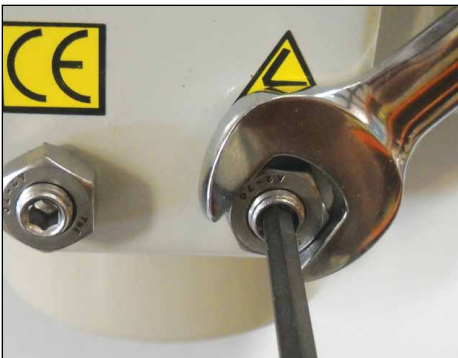

CW Mechanical Stop

Loosen Mechanical Stop

1. BEFORE power is applied, use a 17mm wrench and a 5mm hex key to loosen the RIGHT SIDE mechanical stop. This is the CW stop limit adjustment. Turn the stop screw 5-6 turns CCW to allow electrical cam stop adjustment without running into the mechanical stop screw.
2. Use the manual hand wheel to position the actuator to your required CW position. This must be within +/- 3 degrees of the factory setting.

Adjust Cam 1

3. The lower cam is Cam 1, the CW end-of-travel adjustment. Once the actuator is at its required CW position, with POWER OFF, use a 2.5mm hex key to free up the cam set screw. Once it is free, rotate the hex key to the RIGHT 10-15 degrees to reset the switch roller arm. Then snug the set screw up against the camshaft (CW) until slight pressure is felt. Then SLOWLY rotate the hex key pushing the cam to the LEFT until you hear the "click" on the bottom switch indicating that correct adjustment has been achieved. Tighten the set screw.

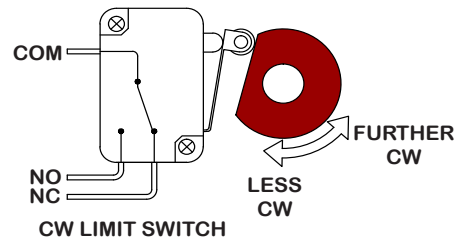

4. Apply power to the actuator and drive CCW at least 15-20 degrees. Then drive the actuator CW until the cam stops the electrical travel. Check to be sure this is the correct CW position you require. Repeat step 3 if further adjustment is needed.

Tighten Mechanical Stop

5. While holding the 17mm wrench on the RIGHT SIDE jam nut to prevent the jam nut from locking, turn the 5mm hex key CW until the end of the stop screw bottoms out against the internal stop boss. Then turn the hex key ONE FULL TURN CCW before locking that adjustment with the jam nut. This procedure assures that the actuator reaches its end of travel electrically before there is any interference from the mechanical stop.

6. This completes the CW position calibration.

Notice! After completing this step, you must initiate a recalibration routine (see AutoCalibration Procedures) in order for the changes to take effect in the controller.

Potentiometer Gear Engagement

During the setting of the CW stop position, make sure that the potentiometer pinion gear and the camshaft sector gear do not drive past the point of engagement. If the sector gear does not have at least 2 full teeth contacting the potentiometer pinion gear, contact your distributor for mechanical recalibration instructions.

The mechanical stop screw limits handwheel operation ONLY and is NOT to be used as an electrical travel limiting device.

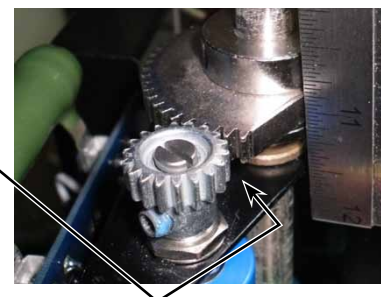

Controller: Adjusting the actuator CCW position

Follow these instructions to adjust the CCW position controlled by the 105 Proportional Controller (standard operation). Proceed to the next page to adjust the CCW position controlled by the travel cam.

(Assumes actuator is powered up, running and is at the default display, showing position).

Press the joystick LEFT twice...	Display reads:	rEdLt, NE
Press the joystick DOWN three times...	Display reads:	SEt tRaduEL
Press the joystick RIGHT once...	Display reads:	AUto SEt
Press the joystick DOWN twice...	Display reads:	FULL oPEn
Press the joystick RIGHT once... (actual position in steps)	Display reads:	00 to 4096

Press joystick UP and HOLD to drive further CCW or press DOWN and HOLD to drive further CW. The adjusted CCW position MUST be between 2500 and 4000 steps.

When the correct CCW position is established, press the joystick IN...	Display reads:	done
Press the joystick LEFT twice...	Display reads:	SEt tRaduEL
Press the joystick UP three times	Display reads:	rEdLt, NE
Press the joystick RIGHT once... DOWN twice, then RIGHT once, the display will now show % of CCW position (0.0 = Fully CW)		00 to 100

FM15_P23 HV PN41135 Ver A 091015

Notice! Performing an Auto Calibration after this procedure will ERASE this custom stop set point and will return to the factory default setting. For this reason, you CANNOT run an Auto Calibration procedure at any time after this setting has been changed.

Cams: Adjusting the actuator CCW position

Serious Damage to the actuator will result if the motor is allowed to drive the gear train into the mechanical stop!! Remove power from this device BEFORE making any travel adjustments.

This actuator has been factory calibrated to operate between 0 degrees and 90 degrees. Most quarter-turn products will not require recalibration of these settings. Proceed **ONLY** if adjustments are required.



CCW Mechanical Stop

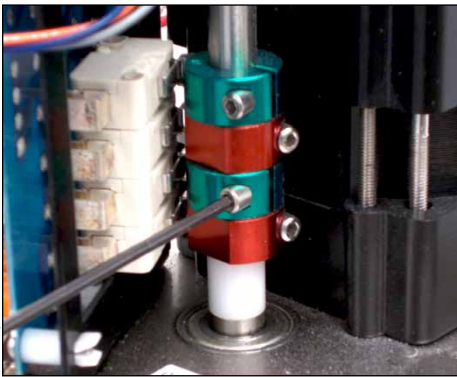

Cam 2



CCW Mechanical Stop

Loosen Mechanical Stop

1. BEFORE power is applied, use a 17mm wrench and a 5mm hex key to loosen the LEFT SIDE mechanical stop. This is the CCW stop limit adjustment. Turn the stop screw 5-6 turns CCW to allow electrical cam stop adjustment without running into the mechanical stop screw.
2. Use the manual hand wheel to position the actuator to your required CCW position. This must be within +/- 3 degrees of the factory setting.

Adjust Cam 2

3. The second cam is Cam 2, the CCW end-of-travel adjustment. Once the actuator is at its required CCW position, with POWER OFF, use a 2.5mm hex key to free up the cam set screw. Once it is free, rotate the hex key to the LEFT 10-15 degrees to reset the switch roller arm. Then snug the set screw up against the camshaft (CW) until slight pressure is felt. Then SLOWLY rotate the hex key pushing the cam to the RIGHT until you hear the "click" on the second switch indicating that correct adjustment has been achieved. Tighten the set screw.

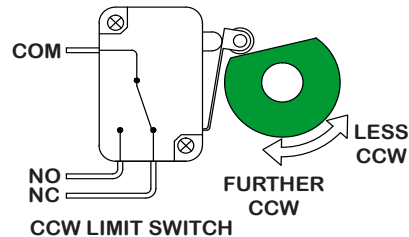

4. Apply power to the actuator and drive CW at least 15-20 degrees. Then drive the actuator CCW until the cam stops the electrical travel. Check to be sure this is the correct CCW position you require. Repeat step 3 if further adjustment is needed.

Tighten Mechanical Stop

5. While holding the 17mm wrench on the LEFT SIDE jam nut to prevent the jam nut from locking, turn the 5mm hex key CW until the end of the stop screw bottoms out against the internal stop boss. Then turn the hex key ONE FULL TURN CCW before locking that adjustment with the jam nut. This procedure assures that the actuator reaches its end of travel electrically before there is any interference from the mechanical stop.
6. This completes the CCW position calibration.

Notice! After completing this step, you must initiate a recalibration routine (see Auto-Calibration Procedures) in order for the changes to take effect in the controller.

The mechanical stop screw limits handwheel operation ONLY and is NOT to be used as an electrical travel limiting device.

Controller: Change Loss of Signal Response Setting

(Assumes actuator is powered up, running and is at the default display, showing position).

Notice: Any changes, settings or new calibration points are lost if a factory "Reset" is performed on the controller. Contact the factory for details.

Press the joystick LEFT twice...	Display reads:	rEALt, NE
Press the joystick DOWN twice...	Display reads:	SEt ProcESS
Press the joystick RIGHT once...	Display reads:	in dnd out
Press the joystick DOWN once...	Display reads:	INPUt FAULT
Press the Joystick RIGHT once...	Display reads:	FAULT LEvEL
Press the Joystick DOWN once...	Display reads:	FAULT PoSi, ti on
Press the Joystick RIGHT once...	Display reads:	-0.1
Press the joystick UP or DOWN to select	Display reads:	-0.1 to 100.0

{The display shows percentage of full CCW. i.e. 100.0 = full CCW.
50.0 = 50% CCW, 0.0 = Full CW. -0.1 = Fail in position (no move)}

After selection is displayed, press the joystick IN...

	Display reads:	done
Press the joystick LEFT three times...	Display reads:	SEt ProcESS
Press the joystick UP twice...	Display reads:	rEALt, NE
Press the joystick RIGHT once... DOWN twice, then RIGHT once, the display will now show % of CCW position (0.0 = Fully CW)		00 to 100

FM15_P23 HV PN4135 Ver A 091015

Controller: Auto-Calibration Procedure

(Assumes actuator is powered up, running and is at the default display, showing position).

Notice: Any changes, settings or new calibration points are lost if a factory "Reset" is performed on the controller. Contact the factory for details.

Press the joystick LEFT twice...	Display reads:	<i>rEdLt, NE</i>
Press the joystick DOWN three times...	Display reads:	<i>SEt tRaduEL</i>
Press the joystick RIGHT once...	Display reads:	<i>AUtO SEt</i>
Press the joystick RIGHT once...	Display reads:	<i>PUSH to rUn</i>

Press the joystick IN. The display will show calibration routines AC1 through AC10, moving the actuator to different positions and recording data at each step. When the auto calibration routine is complete, the actuator will be in the fully CW position, and the display will read:

done

Press the joystick LEFT twice...	Display reads:	<i>SEt tRaduEL</i>
Press the joystick UP three times	Display reads:	<i>rEdLt, NE</i>

Press the joystick RIGHT once... DOWN twice, then RIGHT once, the display will now show % of CCW position (0.0 = Fully CW)

00 to 100

Cams: Adjusting the actuator Auxiliary Switches

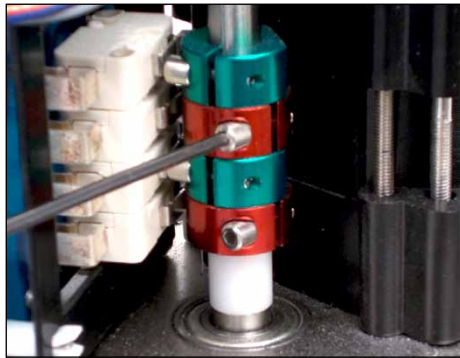

Cam 3

Adjust Cam 3

1. The THIRD cam is Cam 3, the CW auxiliary switch adjustment. Drive the actuator to its CW position. Then use a 2.5mm hex key to free up the cam set screw. Once it is free, rotate the hex key to the RIGHT 10-15 degrees to reset the switch roller arm. Then snug the set screw up against the camshaft (CW) until slight pressure is felt. Then SLOWLY rotate the hex key and cam to the LEFT until you hear the “click” on the third switch. Continue to rotate the cam between 3 and 5 degrees to the LEFT to make sure the auxiliary cam switch changes state before the actuator reaches its end of travel electrically. Tighten the cam set screw.

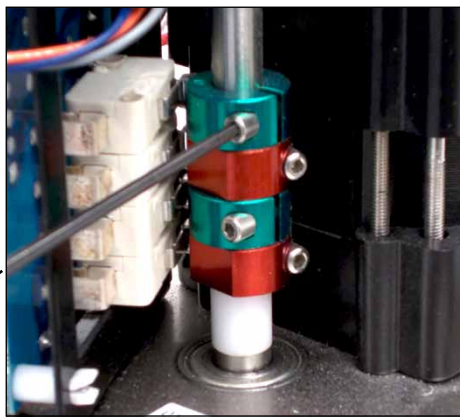

Cam 4

Adjust Cam 4

1. The FOURTH cam is Cam 4, the CCW auxiliary switch adjustment. Drive the actuator to its CCW position. Then use a 2.5mm hex key to free up the cam set screw. Once it is free, rotate the hex key to the LEFT 10-15 degrees to reset the switch roller arm. Then snug the set screw up against the camshaft (CW) until slight pressure is felt. Then SLOWLY rotate the hex key to the RIGHT until you hear the “click” on the fourth switch. Continue to rotate the cam between 3 and 5 degrees to the RIGHT to make sure the auxiliary cam switch changes state before the actuator reaches its end of travel electrically. Tighten the cam set screw.

Commissioning

After completing all mounting and wiring procedures and main power is available, it is now possible to commission the actuator.

1. Utilize the handwheel to rotate the actuator and damper, valve or other connected device through its full travel from full CW to full CCW and back again to check for any possible interference. Do NOT utilize any mechanical advantage devices to rotate the handwheel (pipes, wrenches, extension bars, etc.).
2. Apply correct power to the unit.
3. Measure correct power on terminals 2 (Hot) and 1 (Neu) on the switch board.
4. Measure correct power on the two heater terminals on the switch board.
5. Command the field device to generate a CCW signal. The actuator rotates in a CCW direction (as viewed from above).
6. Measure terminals 1 (Neu) and 6 (Hot) for correct voltage (matching that measured in step 3).
7. Actuator will stop when it reaches it's full CCW position.
8. Command the field device to generate a CW signal. The actuator rotates in a CW direction (as viewed from above).
9. Measure terminals 1 (Neu) and 4 (Hot) for correct voltage (matching that measured in step 3).
10. Actuator will stop when it reaches it's full CW position.
11. Actuator is now commissioned and operational.

Mechanical Data

P2/3 Series Dimensional Data

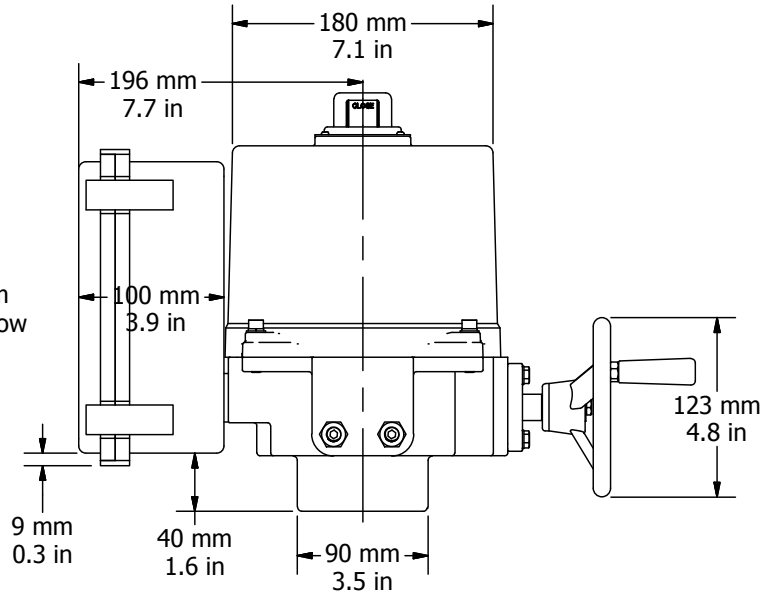
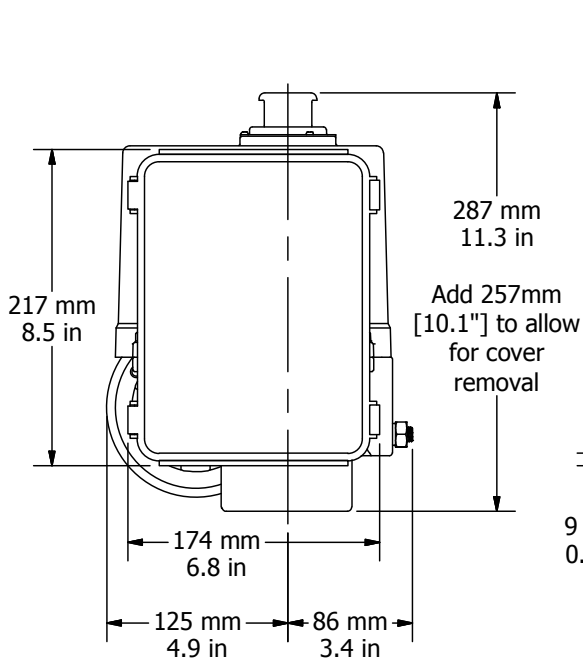
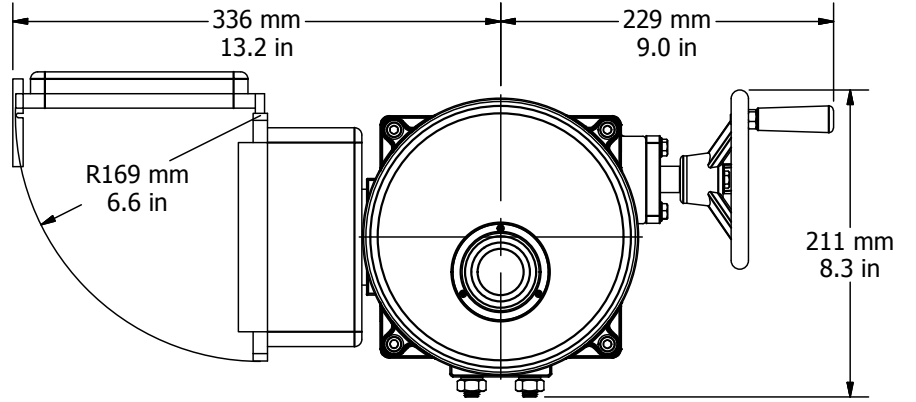
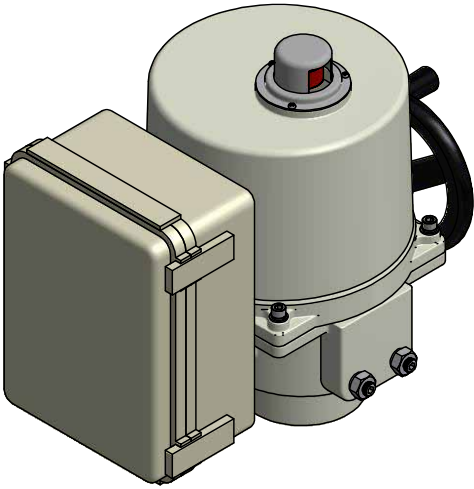

Drive Coupling Fabrication Data

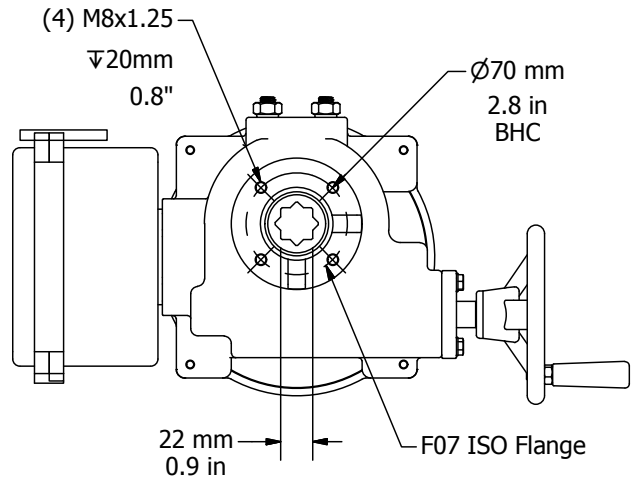
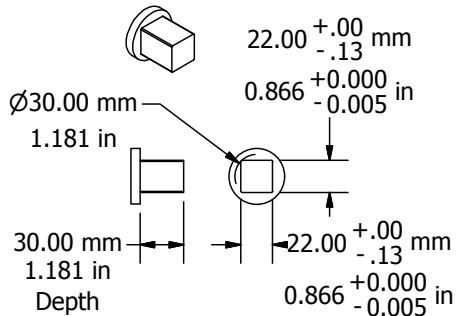

FM15_P23 HV PN4-I135 Ver A 091015

Mechanical Data

P Series Exploded View

(P2/3-120N4 unit is shown)

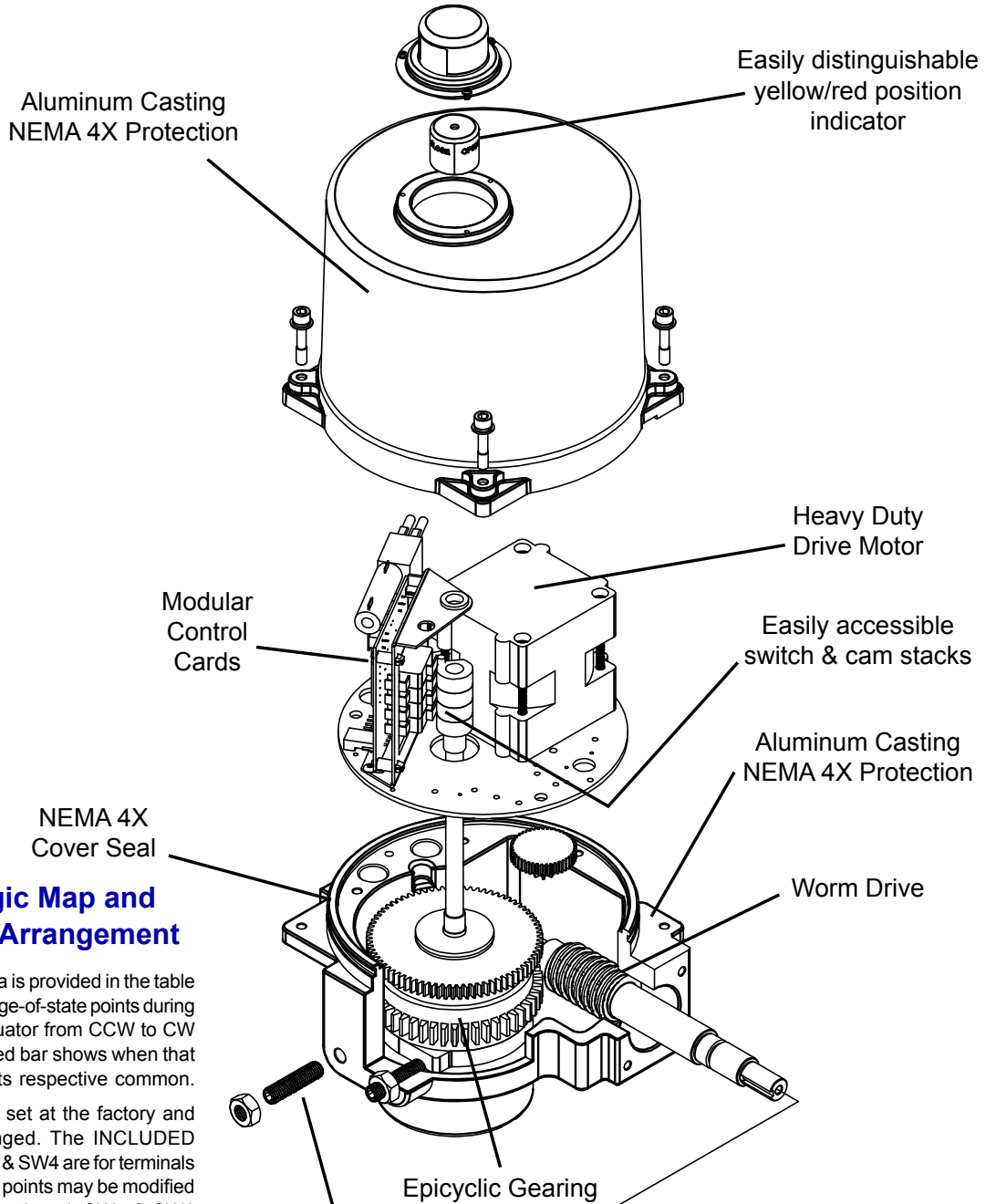

Switch Logic Map and Switch/Cam Arrangement

Switch sequencing data is provided in the table below to show the change-of-state points during the rotation of the actuator from CCW to CW and back again. The red bar shows when that terminal makes with its respective common.

Switches 1 and 2 are set at the factory and should NOT be changed. The INCLUDED auxiliary switches SW3 & SW4 are for terminals 7 thru 12 and those set points may be modified if need be. When so optioned, SW5 & SW6 auxiliary switches are initially set to function the same as auxiliary switches SW3 & SW4.

	cw			ccw		
	-5°	0°	5°	85°	90°	95°
12	Not Open					
11	Open Switch Common					
10	Open					
9	Not Closed					
8	Closed Switch Common					
7	Closed					

SW4 CCW AUX
(Factory Set - Adj)

SW3 CW AUX
(Factory Set - Adj)

Used by
Controller

FM15_P23 HV PN4-135 Ver A 091015

Industrial Applications

ProMation Engineering actuators have been installed to operate process controls such as butterfly valves, ball valves, high performance valves, plug valves, gate valves and dampers, in a broad range of demanding industrial applications.

**Power
Generation**



**Water
Processes**



Mining



Oil and Gas



Agriculture

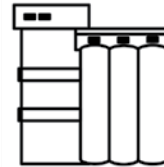

Chemicals



Complete Support

ProMation Engineering is committed to providing superior customer support for your sales, project management and installation teams. Contact us today.

Full Documentation

We offer complete wiring diagrams, field installation manuals and set up documentation for all our products, both in printed and digital form. We regularly host customized educational webinars for our customers.

RapidQuote

Most quotes and estimates are generated within hours of the request.

ProMation Engineering Services

ProMation Engineering can provide design and technical services for OEM's, projects with customized requirements and specialized operations.

ProMation Engineering follows a policy of continual product updates and enhancements. Our website is the best place to obtain the latest product documentation, including the wiring diagrams for these controllers. Visit us at www.promationei.com or use the code to link to the site.



**PROMATION
ENGINEERING**

Precision Actuation for Industry

16138 Flight Path Drive
Brooksville, FL 34604

Phone (352) 544-8436 Fax (352) 544-8439

email: sales@promationei.com



Use your smart phone barcode scanner app here.