



PROMATION ENGINEERING

Precision Actuation for Industry

Data Sheet

P2/3 LV Series

On/Off/Jog / Proportional
ISO5211 F07 8P22

The low voltage (12v and 24v) P series quarter turn actuators have been designed for dependable performance in rugged industrial applications such as skid packages, clean water and wastewater treatment, and damper control.

ProMation Engineering has an extensive stock of electric actuators and can ship product very rapidly, worldwide.

Several key features increase ProMation actuator reliability:

- Cool running DC brush motors deliver 75% duty cycle.
- Easy to see yellow/red raised position indicator.
- Clutchless Manual Override
- Anti-Condensation Heater protects components from moisture.
- Epicyclic geartrains eliminate the need for an unreliable brake.

Also available in 120VAC or 230VAC or 3 phase supply. Separate spec sheets are available for these configurations.

See www.promationei.com for more information or call ProMation Engineering.



Actuator Specifications	P2		P3	
	12vac/vdc	24vac/vdc	12vac/vdc	24vac/vdc
Torque "lb/Nm	800"lbs/90Nm		1335"lbs/150Nm	
Supply Voltage	12vac/vdc	24vac/vdc	12vac/vdc	24vac/vdc
Max Inrush Current	5.2A	4.5A	4.9A	5.0A
Running Current	3.4A	2.2A	4.4A	2.4A
Motor	DC Brush Type			
Runtime (90°@60Hz)	15 sec		22 sec	
Runtime (90°@50Hz)	15 sec		22 sec	
Duty Cycle	75%			
Motor Starts	1200 per hour			
Weight	26lbs/12kg			
Mechanical Connections	ISO5211 F07 8pt 22mm			
Electrical Entry	(2) 3/4" NPT			
Electrical Terminations	12-16ga			
Environmental Rating	NEMA 4/4X			
Manual Override	5" Handwheel			
Control	On/Off-Jog, Proportional			
Actuator Case material	Aluminum Alloy, Powder coated			
Motor Protection	230°F/110°C Thermal F* Class *Totally Enclosed Non-Ventilated Motors			
Ambient Temperature	-22°F to +125°F			
Operating Range	-30°C to +52°C			

Product Notes:

1. The P Series LV models can be ordered as an on/off (two position) model that can also be used in bump/jog applications. Available in 12vac/vdc and 24vac/vdc.
2. It can also be ordered with a **premium internal proportional control card** that accepts a wide range of control signals, generates multiple feedback signals, and has look-ahead fault prevention. Available in 24vac.
3. It can also be ordered with an **internal proportional control card** that accepts a wide range of control signals and 4-20mA feedback signal. Available in 12vdc and 24 vdc.

Duty cycle graph

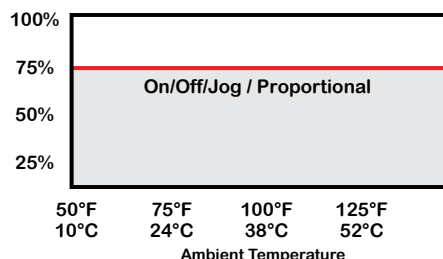

- Duty cycle is defined as the ratio of total time vs. run time, and is a function of environmental conditions including ambient temperature, supply voltage and control signal stability
- Duty Cycle rating on all 12/24VAC/VDC actuators is 75%.

SD16_P28_LV_Ver1_030416

ProMation Premium Controller:

The Premium Proportional Controller offers a full array of features - such as various control and feedback signals, alphanumeric readout, several fault indicators for operational diagnostics, extensive data logging that provides full proportional control for all industrial applications. ModBus communications are also an option on this controller.

Full Proportional Control Featuring:

- Autocalibration
- Programmable
- High resolution
- Alarm Outputs
- Data logging
- Simple User Interface
- Field Selection Friendly
- Thermal Management



Control Signal Inputs

(selectable using program menu):

- 0-10vdc
- 1-5vdc
- 2-10vdc
- 4-20mA

Factory set with common isolated from ground. Ground reference is possible.

Feedback Signal Output

(Can be different than input):

- 0-10vdc
- 1-5vdc
- 2-10vdc
- 4-20mA

Max Load: 250 ohms

Signal	Input Impedance	Sensitivity
0-10vdc	140k ohms	50mV
1-5vdc	250k ohms	20mV
2-10vdc	140k ohms	40mV
4-20mA	250 ohms	80µA

Auxiliary Signal Output

(programmable):

Alarm Contacts allow for signaling of 5 different fault conditions.

2 Position Control

Contacts and capability for 2 position (only) override of the actuator.

- Auxiliary switches are rated 10A @ 250vac MAX.
- Terminals 7-12 are dry type Form C.
- Terminals accept 16-22ga solid/stranded wire.

SAMPLE DIAGRAM

Refer to the proper IOM for your actuator for the correct wiring diagram or visit www.promationei.com.

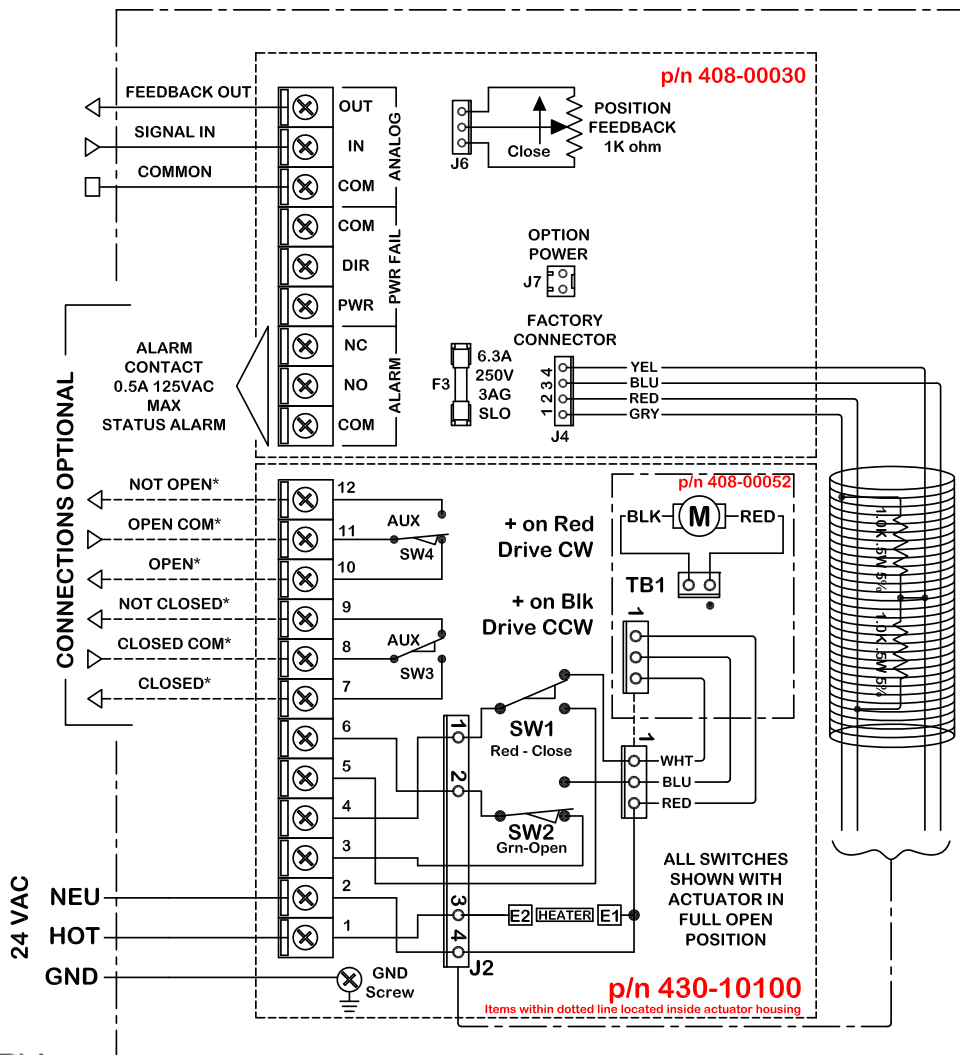

SD16_P28_LV-Ver 1_030416

ProMation DC Proportional Controller:

The Premium controller offers features such as various control and feedback signals, indicators for operational diagnostics, and non-interactive zero and span trimmers for precise actuator performance.

Control Signal Inputs

(selectable using dip switches):

- 0-5vdc
- 0-10vdc
- 1-5vdc
- 2-10vdc
- 4-20mA

Feedback Signal Output

Max Load: 250 ohms

Full Proportional Control Featuring:

- Potentiometric feedback
- Selectable Loss of Signal functions
- Drive / Fault Indicators
- Zero and Span Trimmers



Drive / Fault Indicators
Drive / Fault indicators allow for signaling of 8 different conditions.

Zero and Span Trimmers
Can be set to any position within the usable range of the feedback potentiometer. This allows the unit to be calibrated for direct or reverse acting without rewiring.

Signal	Input Impedance	Sensitivity
0-5vdc	13k ohms	20mV
0-10vdc	13k ohms	50mV
1-5vdc	13k ohms	20mV
2-10vdc	13k ohms	40mV
4-20mA	250 ohms	80µA

- Auxiliary switches are rated 10A @ 250vac MAX.
- Terminals 7-12 are dry type Form C.
- Terminals accept 16-22ga solid/stranded wire.

SAMPLE DIAGRAM

Refer to the proper IOM for your actuator for the correct wiring diagram or visit www.promationei.com.

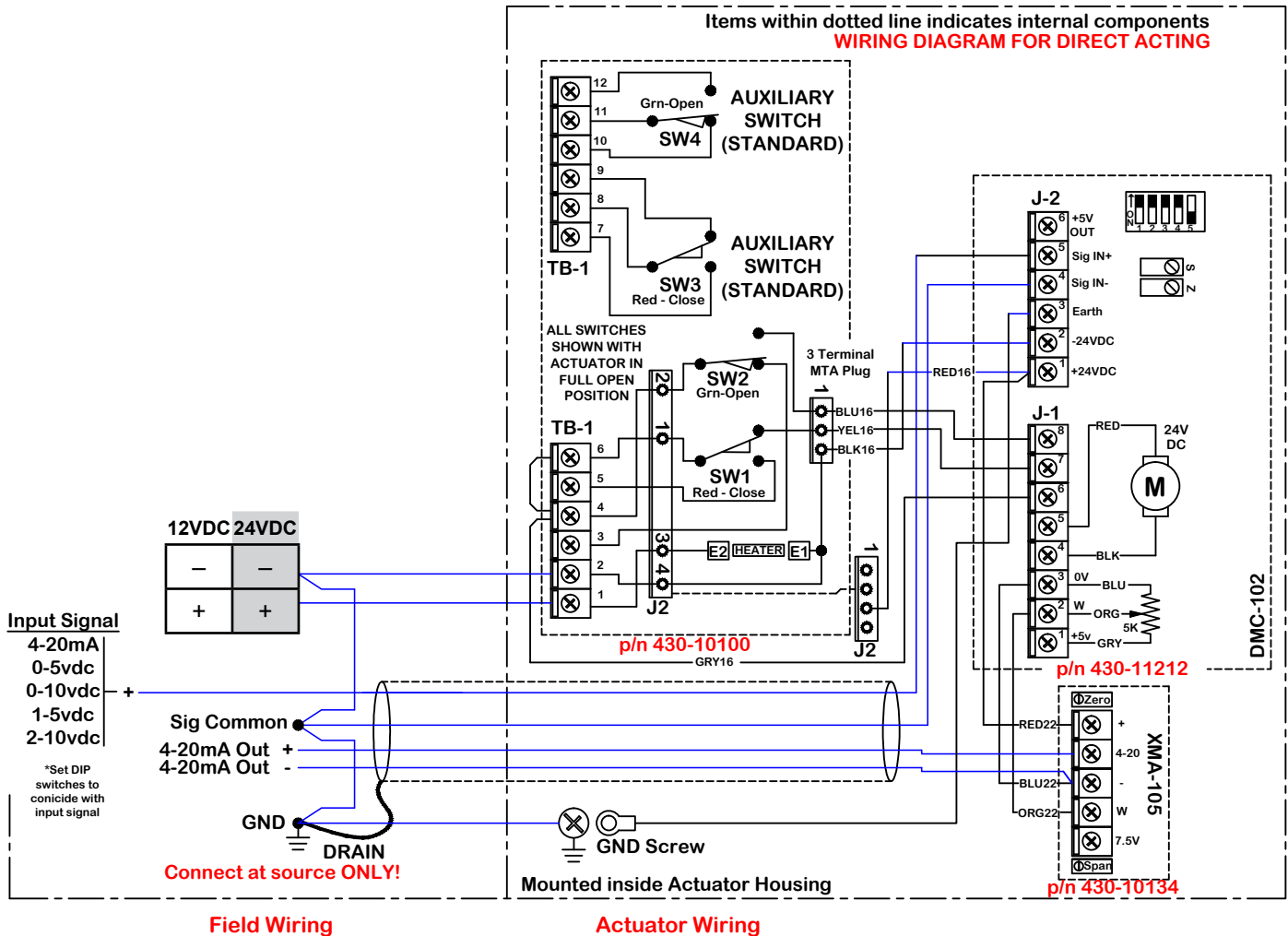

SD16_P28_LV-Ver1_030416

ProMation On/Off/Jog Controller:

The heart of the On/Off/Jog actuator is a robust general purpose relay controlled 12 or 24 vac/vdc controller which drives a 75% duty cycle DC motor. It is suitable for bump/jog operation.

On/Off/Jog Control Featuring:

- Simple Installation
- Drive Indicators
- Switched Pilot Outputs
- Dry Contact Auxiliary Switches
- Optional Connections for position indication
- Upgradeable with a number of factory installed options



- Field Control Device may be relay contact, Switch or Triac type.
- Pilot device 10A MAX.
- Auxiliary switches are rated 10A @ 250vac MAX.
- Terminals 7-12 are dry type Form C.
- Terminals accept 16-22ga solid/stranded wire.

SAMPLE DIAGRAM

Refer to the proper IOM for your actuator for the correct wiring diagram or visit www.promationei.com.

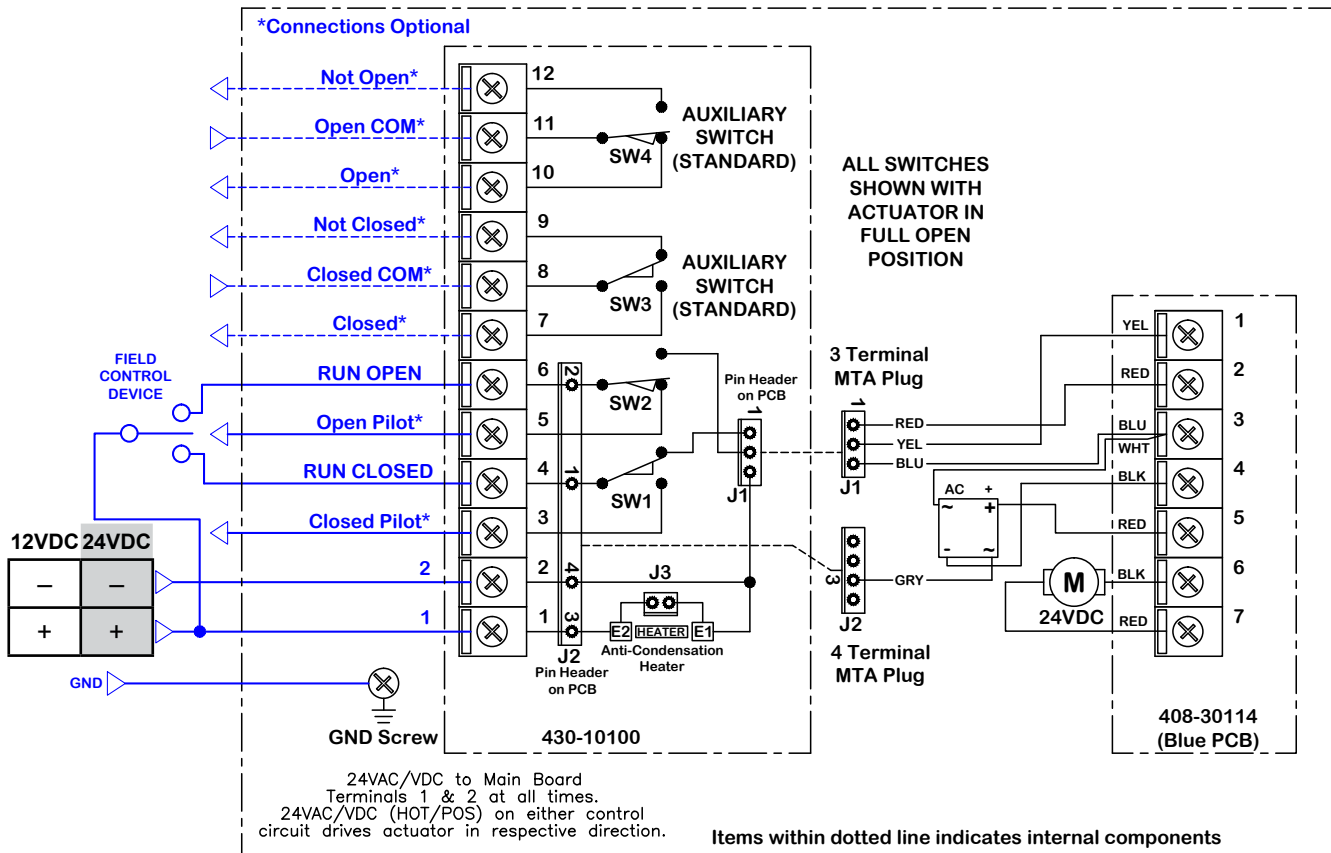

Wire Sizing Chart

Wire sizing data is provided to assist in the selection of the proper wire size for ProMation P Series actuators using various wire sizes over distance.

Please make sure to reference the correct voltage and do not exceed the indicated length of the wire run for each model.

		MAX distance between Actuator and Supply (feet)			
Actuator	Voltage	P2		P3	
		12VAC/VDC	24VAC/VDC	12VAC/VDC	24VAC/VDC
Amps	5.2A	25	58	27	52
	4.5A	40	93	43	84
Wire Gage	5.2A	62	143	65	128
	4.5A	105	242	111	218
		157	362	166	326

P2/3 Series Dimensional Data

P2/3 Series Views

(Typical)

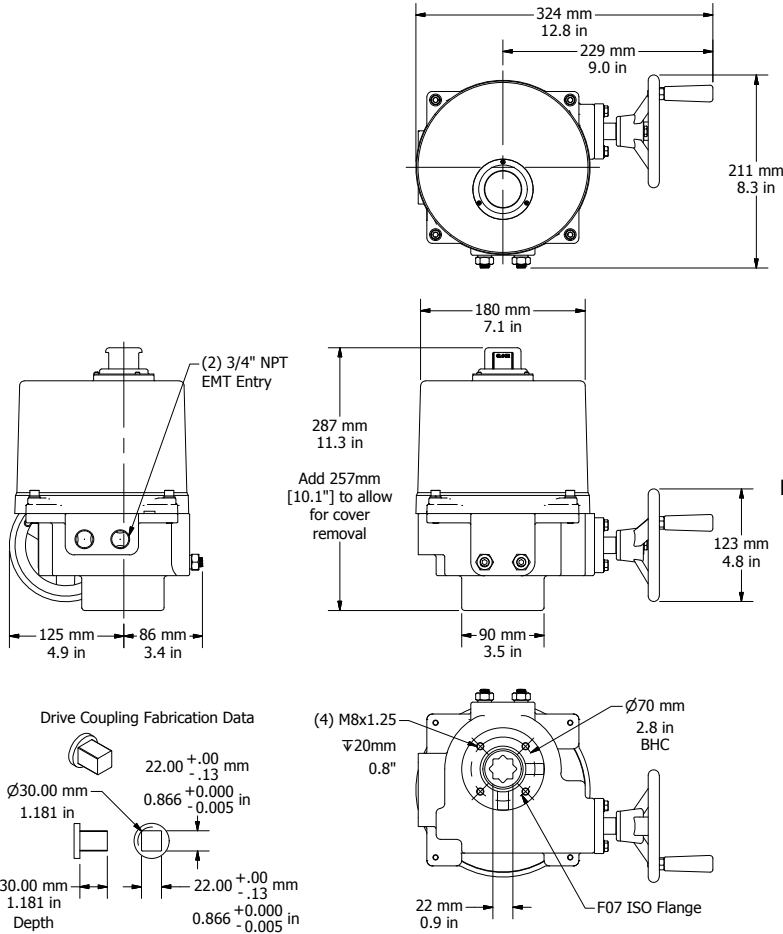

P Series Exploded View

(Typical)

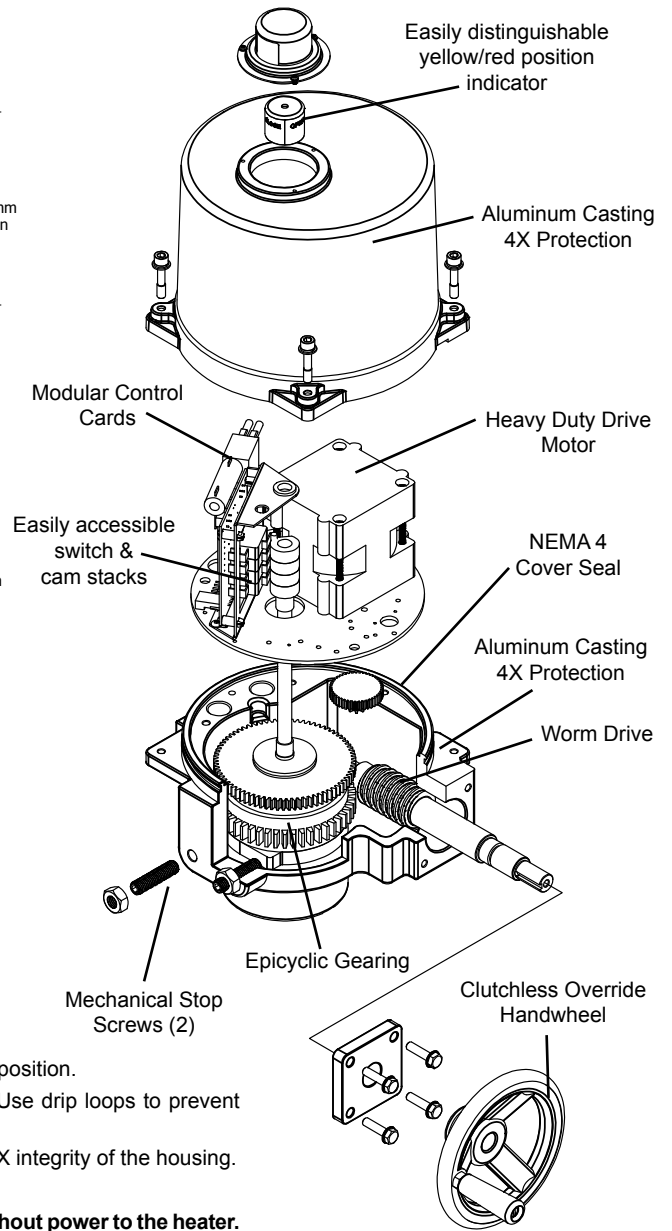

Application Notes:

1. These actuators are to be mounted ONLY between a horizontal and upright position.
2. When installing conduit, use proper techniques for entry into the actuator. Use drip loops to prevent conduit condensate from entering the actuator.
3. Both NPT conduit ports MUST use proper equipment to protect the NEMA 4X integrity of the housing.
4. The anti-condensate heater is to be used in ALL applications.
5. **Do not install or store the actuator outdoors or in humid environments without power to the heater.**
6. Use proper wire size to prevent actuator failure (see wire sizing chart).
7. Mechanical travel stops exist to prevent over-rotation for manual override only. They are not intended to stop motor driven rotation.
8. **Do not parallel wire multiple actuators together without utilizing isolation relays!** If this is your intention, please contact ProMation Engineering for a multiple actuator parallel wiring diagram.

Switch Logic Map and Switch/Cam Arrangement

Switch sequencing data is provided in the table below to show the change-of-state points during the rotation of the actuator from OPEN to CLOSED and back again. The red bar indicates when that terminal makes with it's respective common.

SW1 and SW2 are set at the factory and should NOT be changed. The INCLUDED auxiliary switches SW3 & SW4 are for terminals 7 thru 12 and those setpoints may be modified if need be. When so optioned, SW5 & SW6 auxiliary switches are initially set to function the same as auxiliary switches SW3 & SW4.

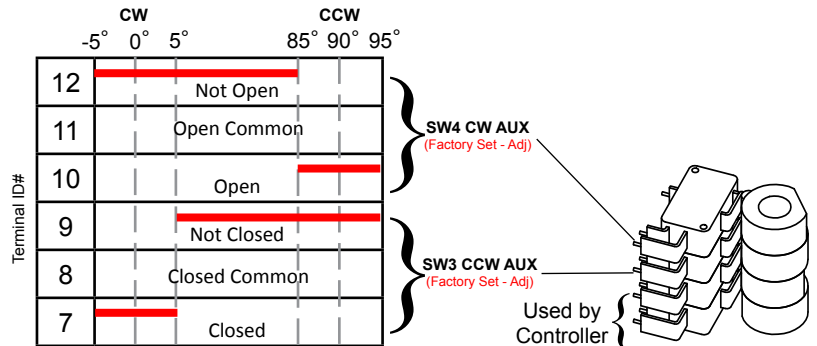

On/Off Switch/Cam arrangement shown



SD16_P28_LV_Ver1_030416

AVAILABLE OPTIONS (Factory Installed)

- Premium Proportional Controller Option. Converts 2 position to proportional control.
- Single Wire Control Relay (Internal) Units operate NORMALLY CLOSED - ENERGIZE TO OPEN.
- Single Wire Control Relay (Internal) Units operate NORMALLY OPEN- ENERGIZE TO CLOSED.
- Mechanical Torque Switch Assembly. P2~P8 except P2/3 24PN4-AC series.
- IP68 Protection, tested to 0.7kgf/cm² for 72 hours. P2~P8 only.
- 0-45-90 degree rotation option.
- 0-90-180 degree rotation option. P2~P8 only.
- 0-180 degree rotation option. No Mid-point position is offered. (On/Off only). P2~P8 only.
- 1k ohm position feedback potentiometer.
- 5k ohm position feedback potentiometer.
- 10k ohm position feedback potentiometer.
- 4-20mA feedback generator for On/Off/Jog actuators.
- Auxiliary Switch set. Provides 3rd and 4th auxiliary switches (Form C x 2).
- Adjustable Timer, Dual Set Point Timer (Duration and Frequency) (Contact factory for application assistance).
- Proportional Control Signal override capability (OPEN OR CLOSED). LV P2~P8 Series only.
- Integral Thermostat for Heater Control - turns on at 32°F, turns off at 50°F.
- Timer function which slows actuator rotation (cycle time) using an internally mounted octal timer. (Contact factory for application assistance). LV P2~P8 series only.
- Chain wheel override for applications where an actuator is mounted some distance from the floor. (Use with LCS).
- Local Control Stations (LCS) ProMation LCSs are designed to be remotely located or directly mounted to the actuator. Proportional actuators will have different options than On/Off. Available in steel, stainless, or fiberglass enclosures. (See catalog for additional Local Control Selections).
- 3 Phase models with or without Motor Control Center.
- Optional SCADA and Modbus compatibility.
- Epoxy coating for increased environmental protection.
- Nylon coating for increased environmental protection.
- Stainless Steel enclosure. P1~P6 Only.

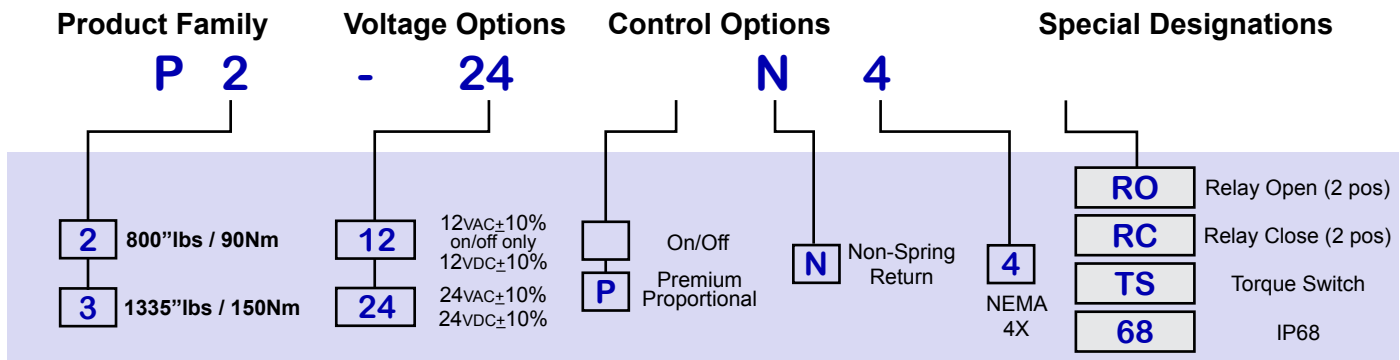

Note: Not all combinations are possible. Please consult factory.

ProMation Product Line



PL Series Linear Drive

Up to 4400lbs down/up force.



P Series Non-Spring Return

55"lbs through 40,000"lbs.



PA~PD Series Spring Return

445"lbs through 2300"lbs.



PBU Battery Back-Up Systems

Provides battery power to drive open

ProMation Engineering follows a policy of continual product updates and enhancements. Our website is the best place to obtain the latest product documentation, including the wiring diagrams for these controllers. Visit us at www.promationei.com or use the QR code below to link to the site.



PROMATION ENGINEERING
Precision Actuation for Industry

16138 Flight Path Drive
Brooksville, FL 34604
Phone (352) 544-8436 Fax (352) 544-8439
email: sales@promationei.com



Use your smart phone barcode scanner app here.