



# PROMATION ENGINEERING

Precision Actuation for Industry

Data Sheet

## P7/8 24V Series

On/Off/Jog/Proportional  
ISO5211 F12 8P36

The 24V P series quarter turn actuators have been designed for dependable performance in rugged industrial applications such as mining, clean water and wastewater treatment, and damper control.

ProMation Engineering has an extensive stock of electric actuators and can ship product very rapidly, worldwide.

Several key features increase ProMation actuator reliability:

- Cool running DC brush motors deliver 75% duty cycle.
- Easy to see yellow/red raised position indicator.
- Clutchless Manual Override
- Anti-Condensation Heater protects components from moisture.
- Epicyclic geartrains eliminate the need for an unreliable brake.

Also available in 120VAC or 230VAC or 3 phase supply. Separate spec sheets are available for these configurations.

See [www.promationei.com](http://www.promationei.com) for more information or call ProMation Engineering.



Actuator Specifications	P7	P8
Torque "lb/Nm	8900"lbs/1000Nm	13250"lbs/1500Nm
Supply Voltage	24vac/vdc	24vac/vdc
Max Inrush Current	7.8A	8.0A
Running Current	6.8A	8.1A
Motor	DC Brush Type	
Runtime (90°@60Hz)	46 sec	46 sec
Runtime (90°@50Hz)	46 sec	46 sec
Duty Cycle	75%	
Motor Starts	1200 per hour	
Weight	82lbs/37kg	
Mechanical Connections	ISO5211 F12 8pt 36mm	
Electrical Entry	(2) 3/4" NPT	
Electrical Terminations	12-16ga	
Environmental Rating	NEMA 4/4X	
Manual Override	11.6" Handwheel	
Control	On/Off-Jog, Proportional	
Actuator Case material	Aluminum Alloy, Powder coated	
Motor Protection	230°F/110°C Thermal F* Class *Totally Enclosed Non-Ventilated Motors	
Ambient Temperature Operating Range	-22°F to +125°F -30°C to +52°C	

### Product Notes:

1. The P Series LV models can be ordered as an on/off (two position) model that can also be used in bump/jog applications. Available in 24vac/vdc.
2. It can also be ordered with a **premium internal proportional control card** that accepts a wide range of control signals, generates multiple feedback signals, and has look-ahead fault prevention. Available in 24vac.
3. It can also be ordered with an **internal proportional control card** that accepts a wide range of control signals and 4-20mA feedback signal. Available in 24 vdc.

### Duty cycle graph

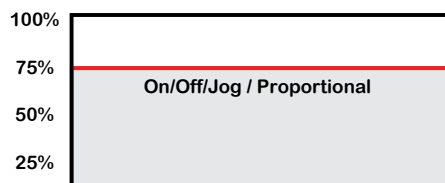

- Duty cycle is defined as the ratio of total time vs. run time, and is a function of environmental conditions including ambient temperature, supply voltage and control signal stability
- Duty Cycle rating on all 24VAC/VDC actuators is 75%.

SD16\_P28\_LV-Ver1\_030416

### ProMation Premium Controller:

The Premium Proportional Controller offers a full array of features - such as various control and feedback signals, alphanumeric readout, several fault indicators for operational diagnostics, extensive data logging that provides full proportional control for all industrial applications. ModBus communications are also an option on this controller.

#### Full Proportional Control Featuring:

- Autocalibration
- Programmable
- High resolution
- Alarm Outputs
- Data logging
- Simple User Interface
- Field Selection Friendly
- Thermal Management



#### Control Signal Inputs

(selectable using program menu):

- 0-10vdc
- 1-5vdc
- 2-10vdc
- 4-20mA

Factory set with common isolated from ground. Ground reference is possible.

#### Feedback Signal Output

(Can be different than input):

- 0-10vdc
- 1-5vdc
- 2-10vdc
- 4-20mA

Max Load: 250 ohms

Signal	Input Impedance	Sensitivity
0-10vdc	140k ohms	50mV
1-5vdc	250k ohms	20mV
2-10vdc	140k ohms	40mV
4-20mA	250 ohms	80µA

#### Auxiliary Signal Output

(programmable):

Alarm Contacts allow for signaling of 5 different fault conditions.

#### 2 Position Control

Contacts and capability for 2 position (only) override of the actuator.

- Auxiliary switches are rated 10A @ 250vac MAX.
- Terminals 7-12 are dry type Form C.
- Terminals accept 16-22ga solid/stranded wire.

### SAMPLE DIAGRAM

Refer to the proper IOM for your actuator for the correct wiring diagram or visit [www.promationei.com](http://www.promationei.com).

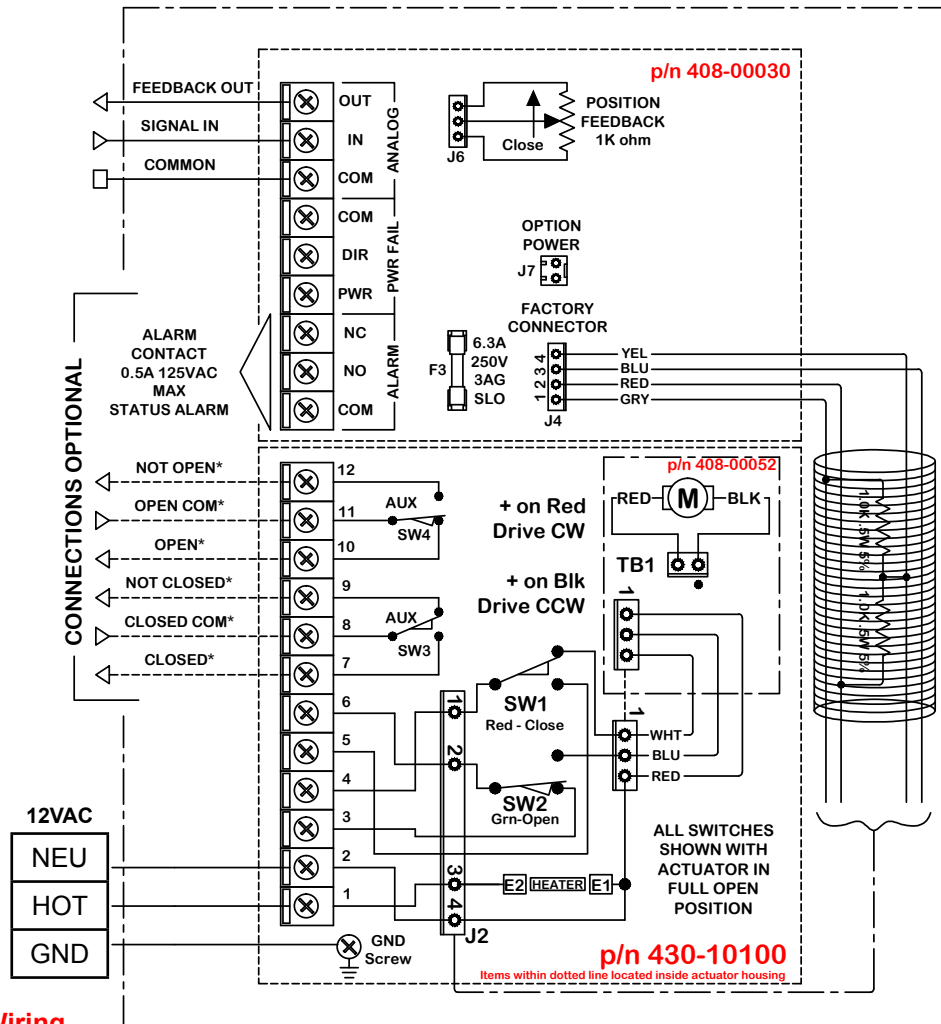

#### Field Wiring

#### Actuator Wiring

### ProMation DC Proportional Controller:

The Premium controller offers features such as various control and feedback signals, indicators for operational diagnostics, and non-interactive zero and span trimmers for precise actuator performance.

#### Full Proportional Control Featuring:

- Potentiometric feedback
- Selectable Loss of Signal functions
- Drive / Fault Indicators
- Zero and Span Trimmers



#### Control Signal Inputs

(selectable using dip switches):

- 0-5vdc
- 0-10vdc
- 1-5vdc
- 2-10vdc
- 4-20mA

#### Feedback Signal Output

Max Load: 250 ohms

**Drive / Fault Indicators**  
Drive / Fault indicators allow for signaling of 8 different conditions.

**Zero and Span Trimmers**  
Can be set to any position within the usable range of the feedback potentiometer. This allows the unit to be calibrated for direct or reverse acting without rewiring.

Signal	Input Impedance	Sensitivity
0-5vdc	13k ohms	20mV
0-10vdc	13k ohms	50mV
1-5vdc	13k ohms	20mV
2-10vdc	13k ohms	40mV
4-20mA	250 ohms	80µA

- Auxiliary switches are rated 10A @ 250vac MAX.
- Terminals 7-12 are dry type Form C.
- Terminals accept 16-22ga solid/stranded wire.

### SAMPLE DIAGRAM

Refer to the proper IOM for your actuator for the correct wiring diagram or visit [www.promationei.com](http://www.promationei.com).

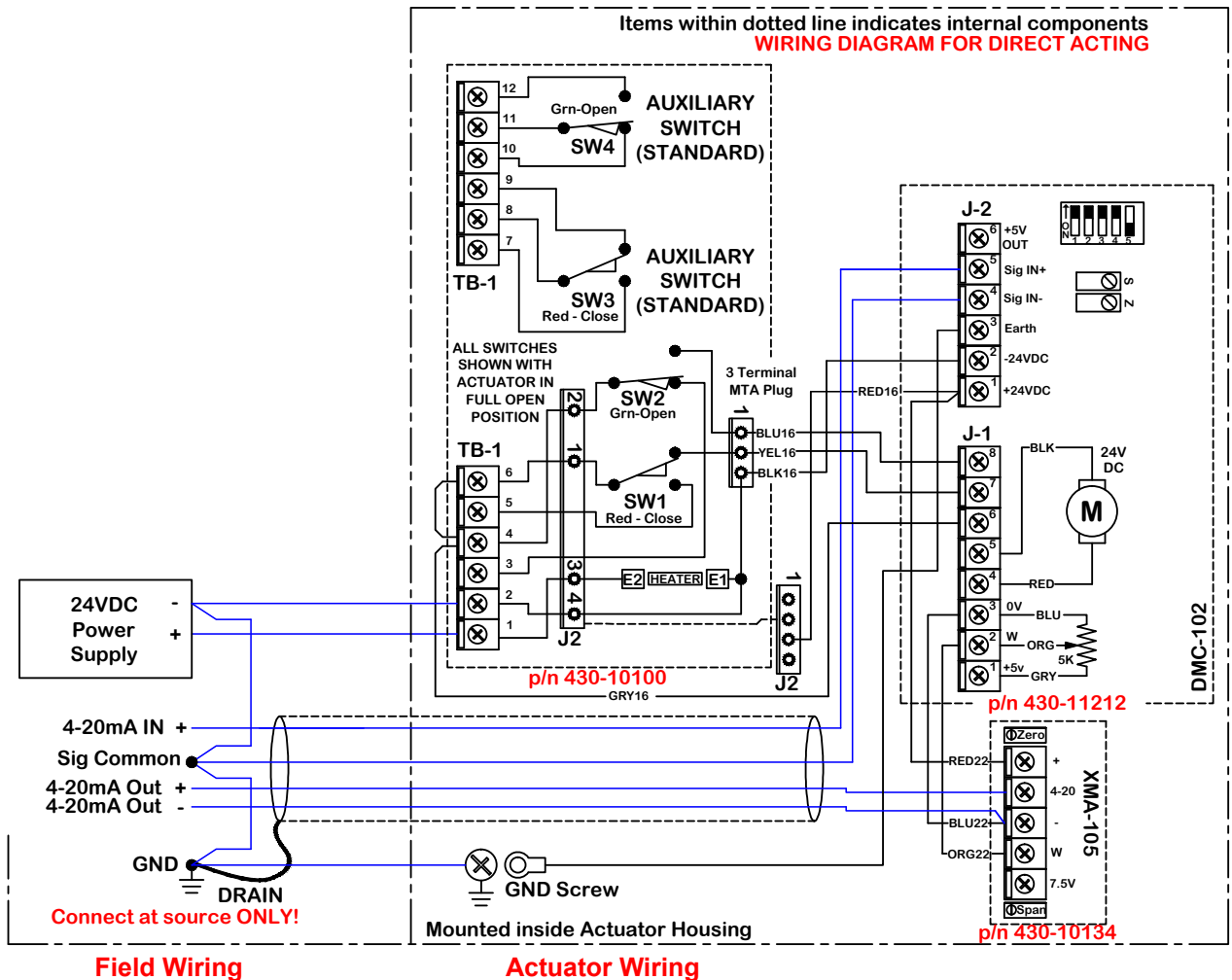

SD16\_P28\_LV-Ver\_L030416

### ProMation On/Off/Jog Controller:

The heart of the On/Off/Jog actuator is a robust general purpose relay controlled 24vac or 24vdc controller which drives a 75% duty cycle DC motor. It is suitable for bump/jog operation.

### On/Off/Jog Control Featuring:

- Simple Installation
- Drive Indicators
- Switched Pilot Outputs
- Dry Contact Auxiliary Switches
- Optional Connections for position indication
- Upgradeable with a number of factory installed options



- Field Control Device may be relay contact, Switch or Triac type.
- Pilot device 10A MAX.
- Auxiliary switches are rated 10A @ 250vac MAX.
- Terminals 7-12 are dry type Form C.
- Terminals accept 16-22ga solid/stranded wire.

### SAMPLE DIAGRAM

Refer to the proper IOM for your actuator for the correct wiring diagram or visit [www.promationei.com](http://www.promationei.com).

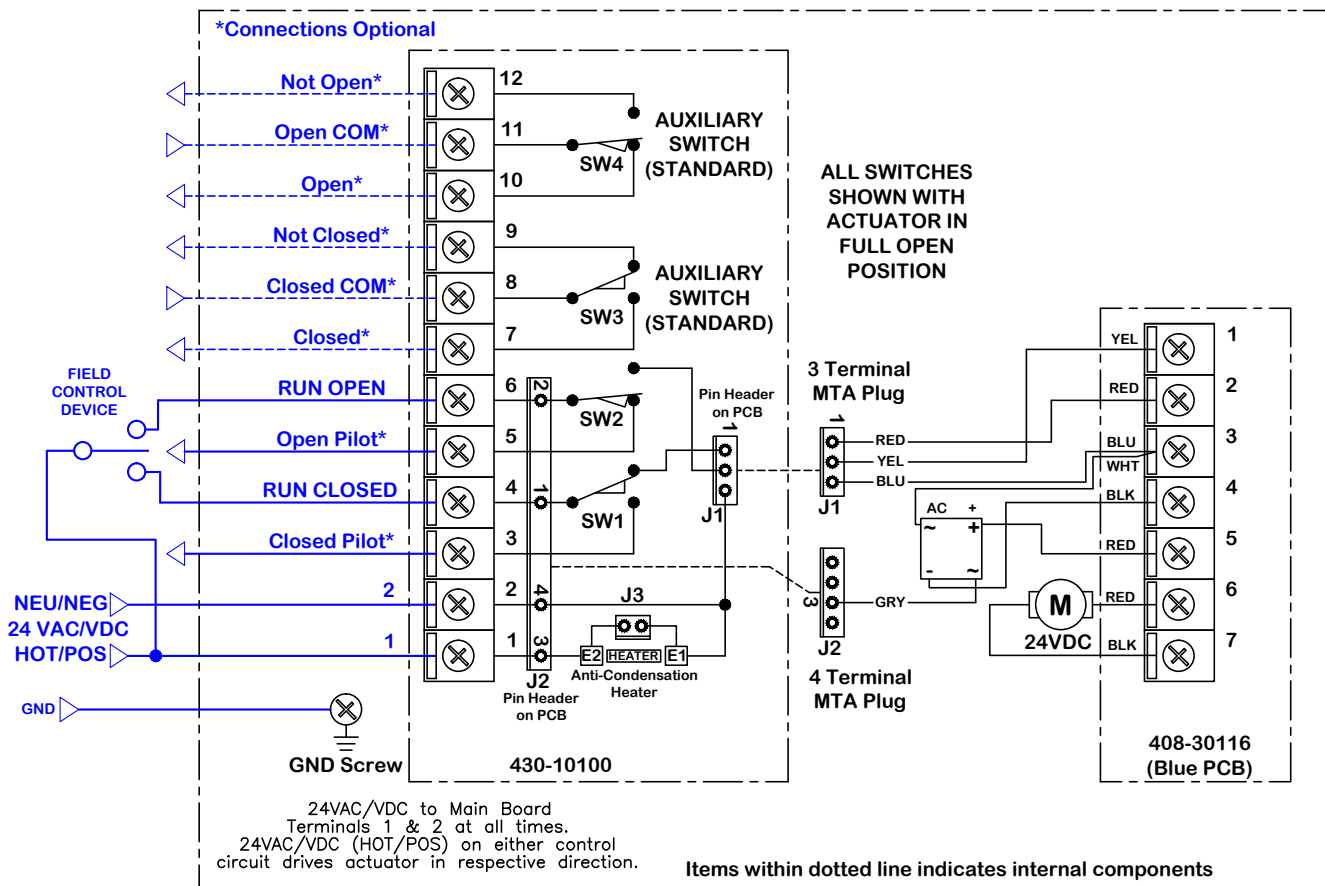

### Field Wiring

### Actuator Wiring

### Wire Sizing Chart

Wire sizing data is provided to assist in the selection of the proper wire size for ProMation P Series actuators using various wire sizes over distance.

Please make sure to reference the correct voltage and do not exceed the indicated length of the wire run for each model.

MAX distance between Actuator and Supply (feet)		
Actuator	P7	P8
Voltage	24VAC/VDC	24VAC/VDC
Amps	7.8A	8.0A
Wire Gage		
16	33	32
14	54	52
12	82	80
10	140	136
8	209	204

# P7/8 Series Dimensional Data

## P7/8 Series Views

(Typical)

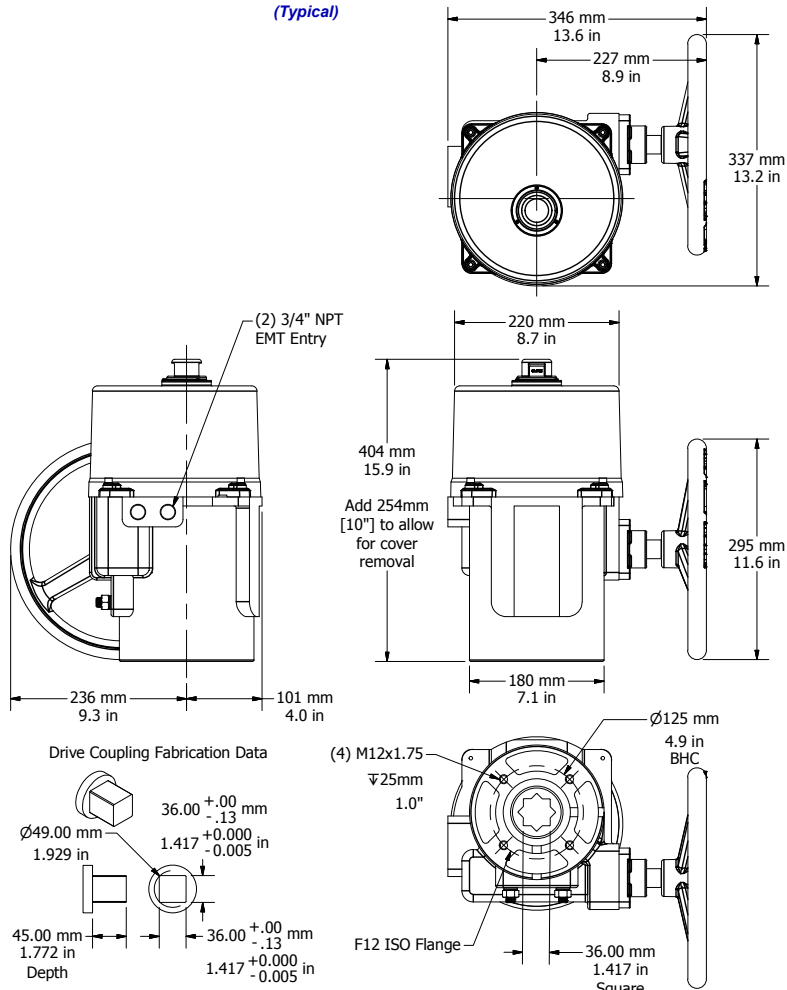

# P Series Exploded View

(Typical)

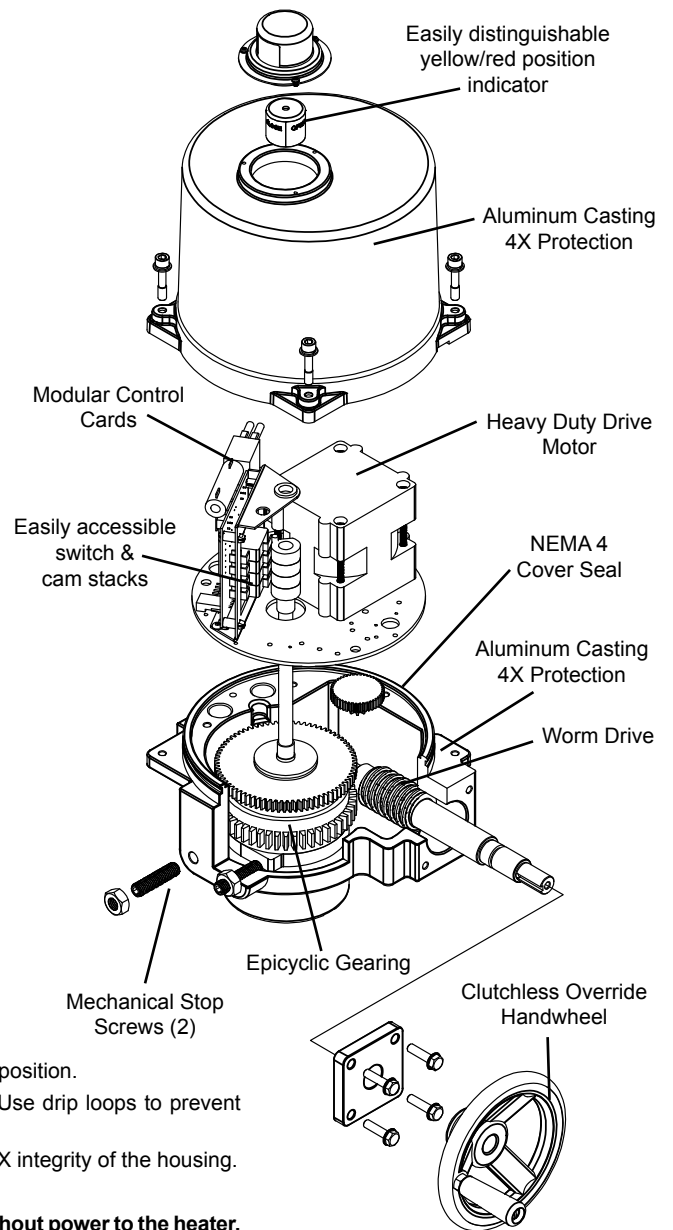

## Application Notes:

1. These actuators are to be mounted ONLY between a horizontal and upright position.
2. When installing conduit, use proper techniques for entry into the actuator. Use drip loops to prevent conduit condensate from entering the actuator.
3. Both NPT conduit ports MUST use proper equipment to protect the NEMA 4X integrity of the housing.
4. The anti-condensate heater is to be used in ALL applications.
5. **Do not install or store the actuator outdoors or in humid environments without power to the heater.**
6. Use proper wire size to prevent actuator failure (see wire sizing chart).
7. Mechanical travel stops exist to prevent over-rotation for manual override only. They are not intended to stop motor driven rotation.
8. **Do not parallel wire multiple actuators together without utilizing isolation relays!** If this is your intention, please contact ProMation Engineering for a multiple actuator parallel wiring diagram.

## Switch Logic Map and Switch/Cam Arrangement

Switch sequencing data is provided in the table below to show the change-of-state points during the rotation of the actuator from OPEN to CLOSED and back again. The red bar indicates when that terminal makes with it's respective common.

SW1 and SW2 are set at the factory and should NOT be changed. The INCLUDED auxiliary switches SW3 & SW4 are for terminals 7 thru 12 and those setpoints may be modified if need be. When so optioned, SW5 & SW6 auxiliary switches are initially set to function the same as auxiliary switches SW3 & SW4.

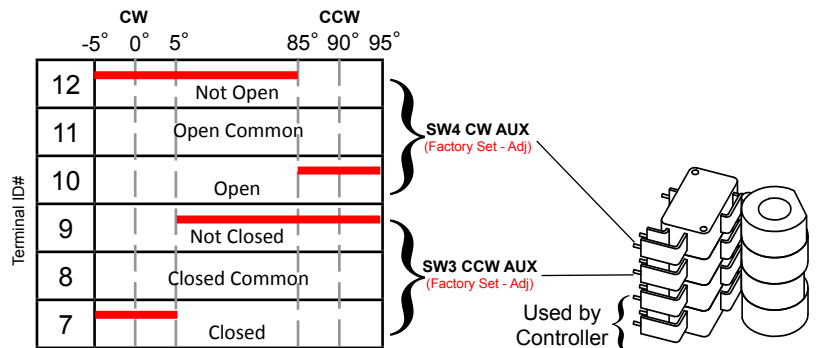

On/Off Switch/Cam arrangement shown



SD16\_P28\_LV\_Ver\_L030416

## AVAILABLE OPTIONS (Factory Installed)

- Premium Proportional Controller Option. Converts 2 position to proportional control.
- Single Wire Control Relay (Internal) Units operate NORMALLY CLOSED - ENERGIZE TO OPEN.
- Single Wire Control Relay (Internal) Units operate NORMALLY OPEN- ENERGIZE TO CLOSED.
- Mechanical Torque Switch Assembly. P2~P8 except P2/3 24PN4-AC series.
- IP68 Protection, tested to 0.7kgf/cm<sup>2</sup> for 72 hours. P2~P8 only.
- 0-45-90 degree rotation option.
- 0-90-180 degree rotation option. P2~P8 only.
- 0-180 degree rotation option. No Mid-point position is offered. (On/Off only). P2~P8 only.
- 1k ohm position feedback potentiometer.
- 5k ohm position feedback potentiometer.
- 10k ohm position feedback potentiometer.
- 4-20mA feedback generator for On/Off/Jog actuators.
- Auxiliary Switch set. Provides 3rd and 4th auxiliary switches (Form C x 2).
- Adjustable Timer, Dual Set Point Timer (Duration and Frequency) (Contact factory for application assistance).
- Proportional Control Signal override capability (OPEN OR CLOSED). LV P2~P8 Series only.
- Integral Thermostat for Heater Control - turns on at 32°F, turns off at 50°F.
- Timer function which slows actuator rotation (cycle time) using an internally mounted octal timer. (Contact factory for application assistance). LV P2~P8 series only.
- Chain wheel override for applications where an actuator is mounted some distance from the floor. (Use with LCS).
- Local Control Stations (LCS) ProMation LCSs are designed to be remotely located or directly mounted to the actuator. Proportional actuators will have different options than On/Off. Available in steel, stainless, or fiberglass enclosures. (See catalog for additional Local Control Selections).
- 3 Phase models with or without Motor Control Center.
- Optional SCADA and Modbus compatibility.
- Epoxy coating for increased environmental protection.
- Nylon coating for increased environmental protection.
- Stainless Steel enclosure. P1~P6 Only.

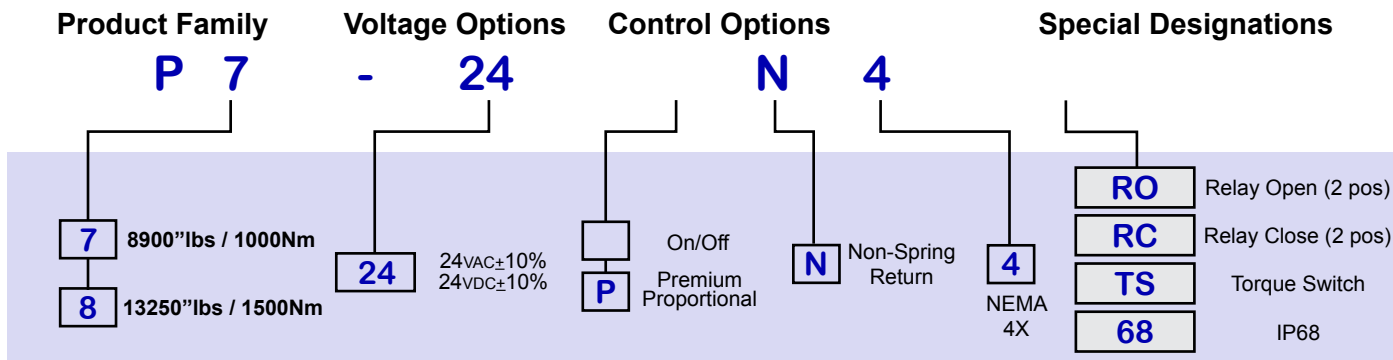

Note: Not all combinations are possible. Please consult factory.

## ProMation Product Line



**PL Series Linear Drive**

Up to 4400lbs down/up force.



**P Series Non-Spring Return**

55"lbs through 40,000"lbs.



**PA~PD Series Spring Return**

445"lbs through 2300"lbs.



**PBU Battery Back-Up Systems**

Provides battery power to drive open

ProMation Engineering follows a policy of continual product updates and enhancements. Our website is the best place to obtain the latest product documentation, including the wiring diagrams for these controllers. Visit us at [www.promationei.com](http://www.promationei.com) or use the QR code below to link to the site.



**PROMATION ENGINEERING**  
Precision Actuation for Industry

16138 Flight Path Drive  
Brooksville, FL 34604  
Phone (352) 544-8436 Fax (352) 544-8439  
email: [sales@promationei.com](mailto:sales@promationei.com)



Use your smart phone barcode scanner app here.