

rev	change date	revision	name	10/31/2014	10/31/2014 1:24 PM	WD-850-24502.dwg
C	10.31.2014	Corrected RC wiring	RHL			
d						
e						
f						
g						
h						
i						
j						
noming			material no			
none			ind			
none			Wiring Diagram			
none			material			
none			WD-850-24502			
none			Normally OPEN (Relay to Close) wiring diagram for 120vac P2/3 actuators.			
none			REV			
none			C			

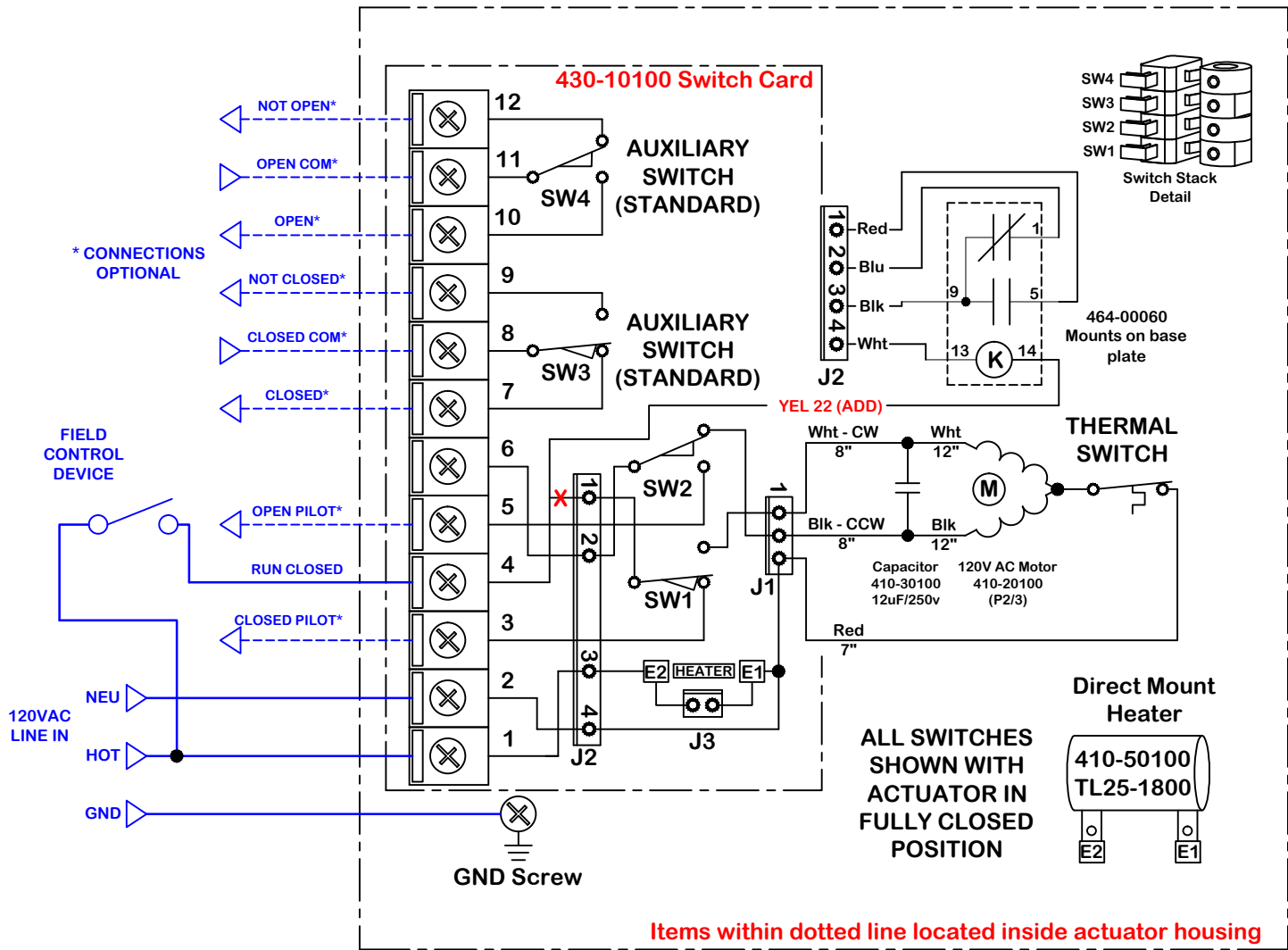

Use For:

P2/3-120N4-RC

Actuator ships in fully OPEN position!

This document is the property of ProMation Engineering, Inc. Distribution of this document without the written consent of the owner is strictly forbidden. Failure to comply will incur a liability for damages.