

rev	change date	revision	name	scale	material no	ind	Wiring Diagram
c							
d							
e							
f							
g							
h							
i							
j							
noming							
dwn by: BJW				Date			
				7.3.2013			
Promation				NONE			
1/28/2014 10:46 AM							
WD-850-25501.dwg							
Normally CLOSED (Relay to Open) wiring diagram for 230vac P2/3 actuators.							
REV							
A							

WD-850-25501

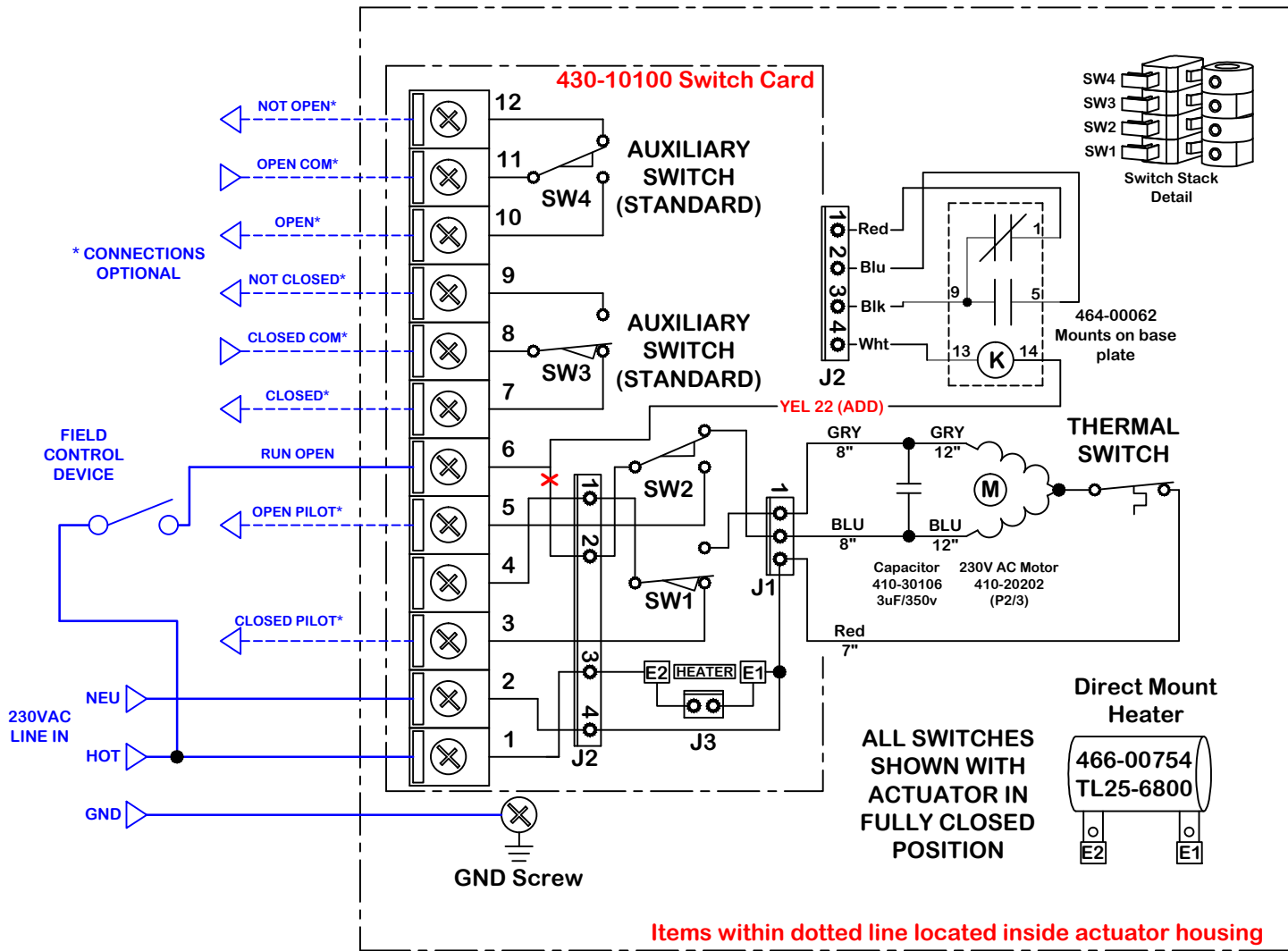

Actuator ships in fully closed position!

Use For:

P2/3-230N4-RO

ProMation Engineering, Inc.
16138 Flight Path Drive
Brooksville, FL 34604
Ph:352-544-8436 Fx(352-544-8439)

This document is the property of ProMation Engineering, Inc.
Distribution of this document without the written consent of the owner is strictly forbidden.
Failure to comply will incur a liability for damages.