

rev	change date	04/20/2015	name	8/30/2016 3:29 PM	WD-850-2K101.dwg
c	revision	New Document	name	8/30/2016 3:29 PM	WD-850-2K101.dwg
d	revision		name	8/30/2016 3:29 PM	WD-850-2K101.dwg
e	revision		name	8/30/2016 3:29 PM	WD-850-2K101.dwg
f	revision		name	8/30/2016 3:29 PM	WD-850-2K101.dwg
g	revision		name	8/30/2016 3:29 PM	WD-850-2K101.dwg
h	revision		name	8/30/2016 3:29 PM	WD-850-2K101.dwg
i	revision		name	8/30/2016 3:29 PM	WD-850-2K101.dwg
j	revision		name	8/30/2016 3:29 PM	WD-850-2K101.dwg
noming			material no		
noming			ind		
noming			Wiring Diagram		
noming			material		
noming			REV		
noming			C		
noming			ProMation Engineering, Inc. 16138 Flight Path Drive Brooksville, FL 34604 Ph:352-544-8436 Fx(352-544-8439		

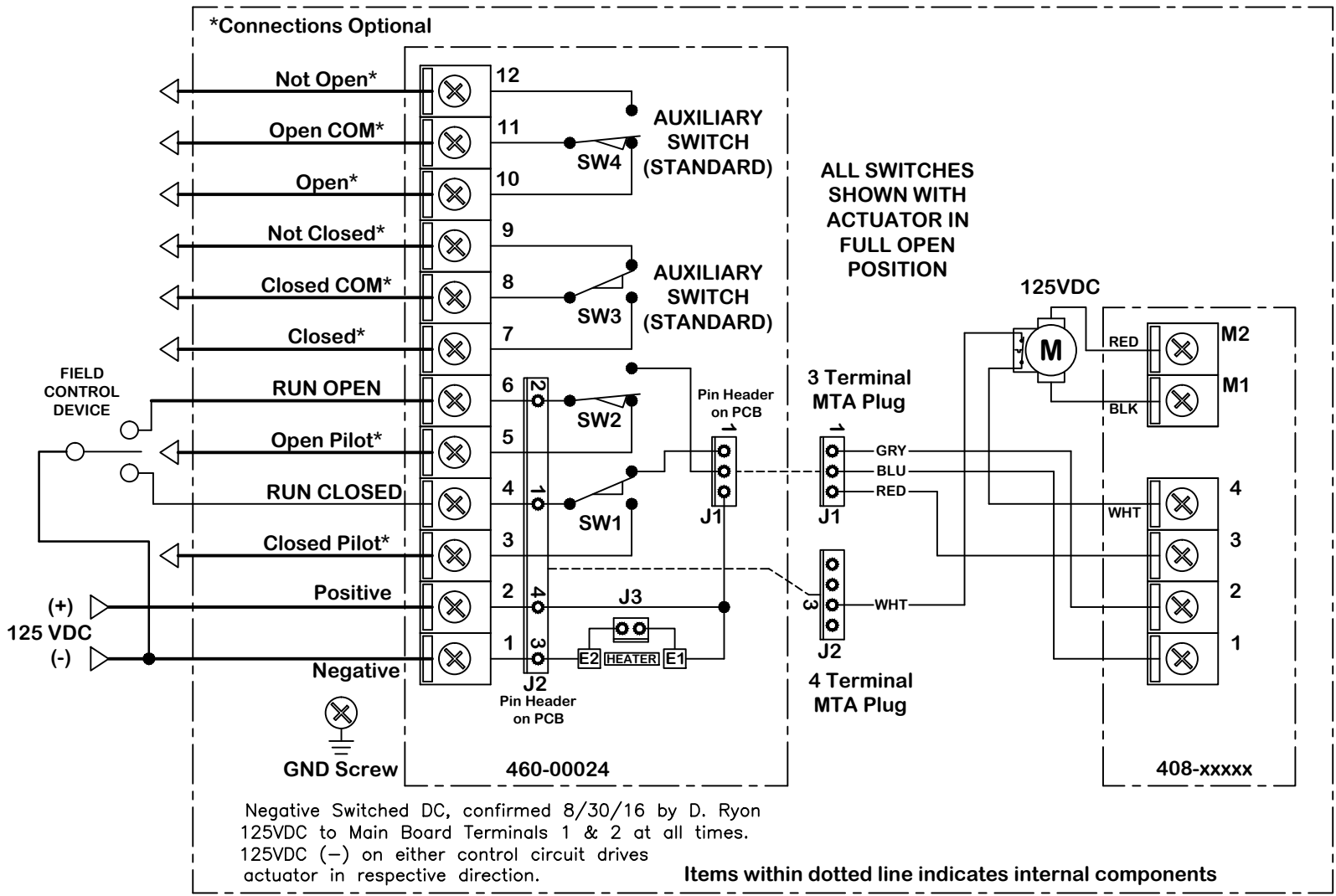

Use For:

P2/3-125N4-DC

Actuator ships in fully closed position!

This document is the property of ProMation Engineering, Inc. Distribution of this document without the written consent of the owner is strictly forbidden. Failure to comply will incur a liability for damages.