

rev change date	10/04/22	revision	rev from WD-850-042821 Modbus communications	name	DUG	10/7/2022 2:35 PM	ProMation	WD-850-042821 A.dwg	REV	A
morning				dwn by:		Date	BJW	6.26.2015	Wiring Diagram	
material no				ind		material		Wiring Diagram		
scale				NONE		Wiring Diagram for Modbus Control		WD-850-042821 A		
P2-8 Series 120vac Actuators				P2-8 Series 120vac Actuators		P2-8 Series 120vac Actuators		P2-8 Series 120vac Actuators		

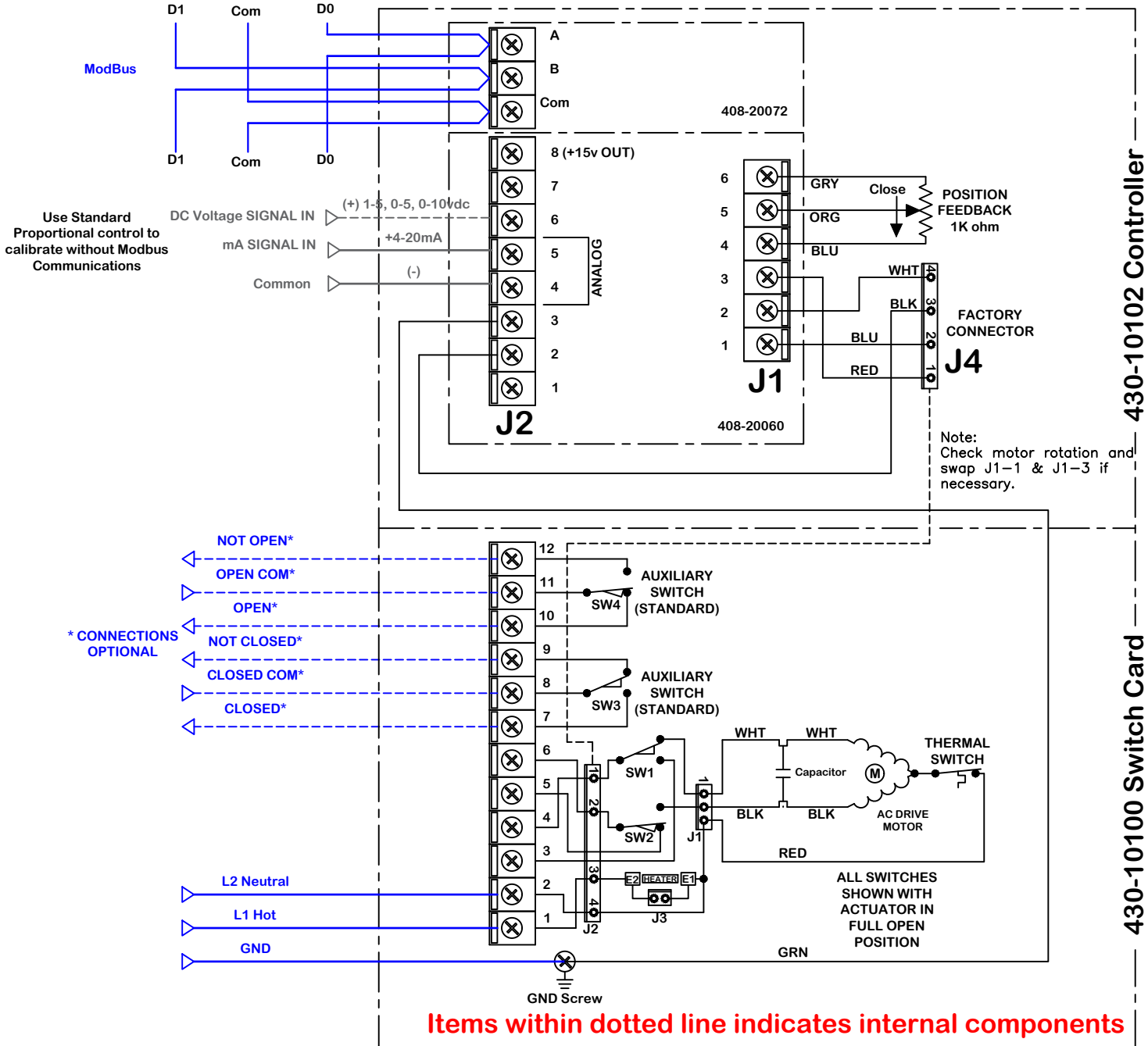

Use For:

P(2-13) 120PN4(7)-Modbus

Actuator ships in fully closed position!

This document is the property of ProMation Engineering, Inc. Distribution of this document without the written consent of the owner is strictly forbidden. Failure to comply will incur a liability for damages.