

rev change	date	revision	name	date	date	date	date	date	date
g									
f									
e									
d									
c									
b	12/27/2016	Added Fob directions							
a	12/27/2016	Changed to # pin connector to Relays new file # from WD 850 24N00							
q	12/27/2016	Added Wires to P2/3 120 on off							
naming									
material no									
ind									
Wiring Diagram									
material									
dwn by: Date									
BJW 5.12.2015									
scale									
NONE									
Promotion									
On/Off wiring diagram for 120vac P2/3									
Wireless open close switching									
WD-850-04N00.dwg									
REV									
B									

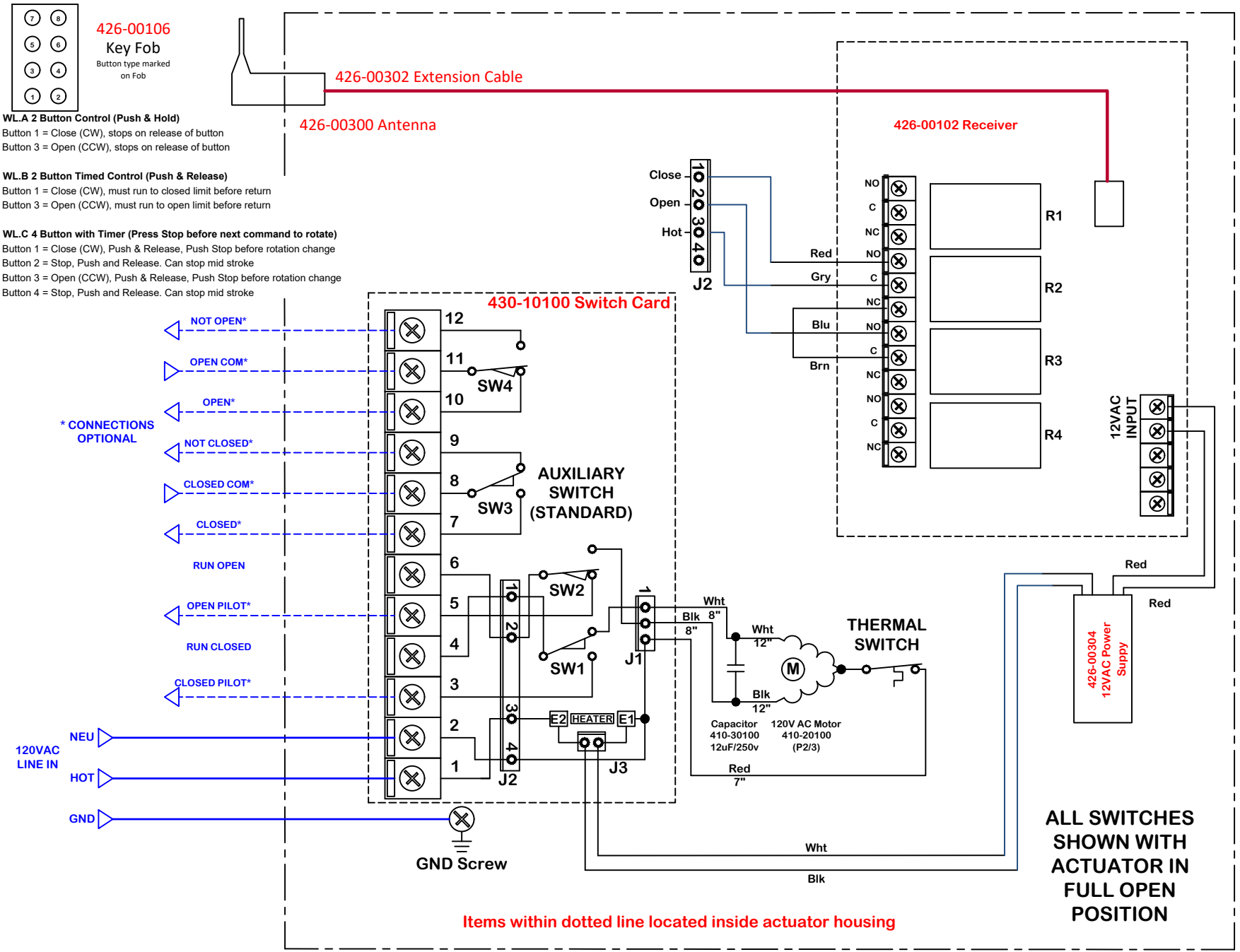

Use For:

# P2-13-120N4-WL

**Actuator ships in fully closed position!**

This document is the property of ProMation Engineering, Inc. Distribution of this document without the written consent of the owner is strictly forbidden. Failure to comply will incur a liability for damages.