

rev	change date	revision	name	7/31/2023 3:57 PM	WD-850-P2201 B.dwg
b	07/31/23	Add optional loop wiring or power for feedback New Drawing from P2201 with DAC 400 Controller	DWG		
d	10/05/21		DWG		
e					
f					
g					
h					
naming		dwn by: DJG		Date: 01.12.21	
material no		scale: NONE			
ind		Wiring Diagram			
material		WD-850-P2201 B			
REV		B			
ProMation Engineering, Inc. 16138 Flight Path Drive Brooksville, FL 34604 Ph:352-544-8436 Fx:352-544-8439		Wiring Diagram for Proportional Control. P2~P8 Series 24VDC with HR 400 control			

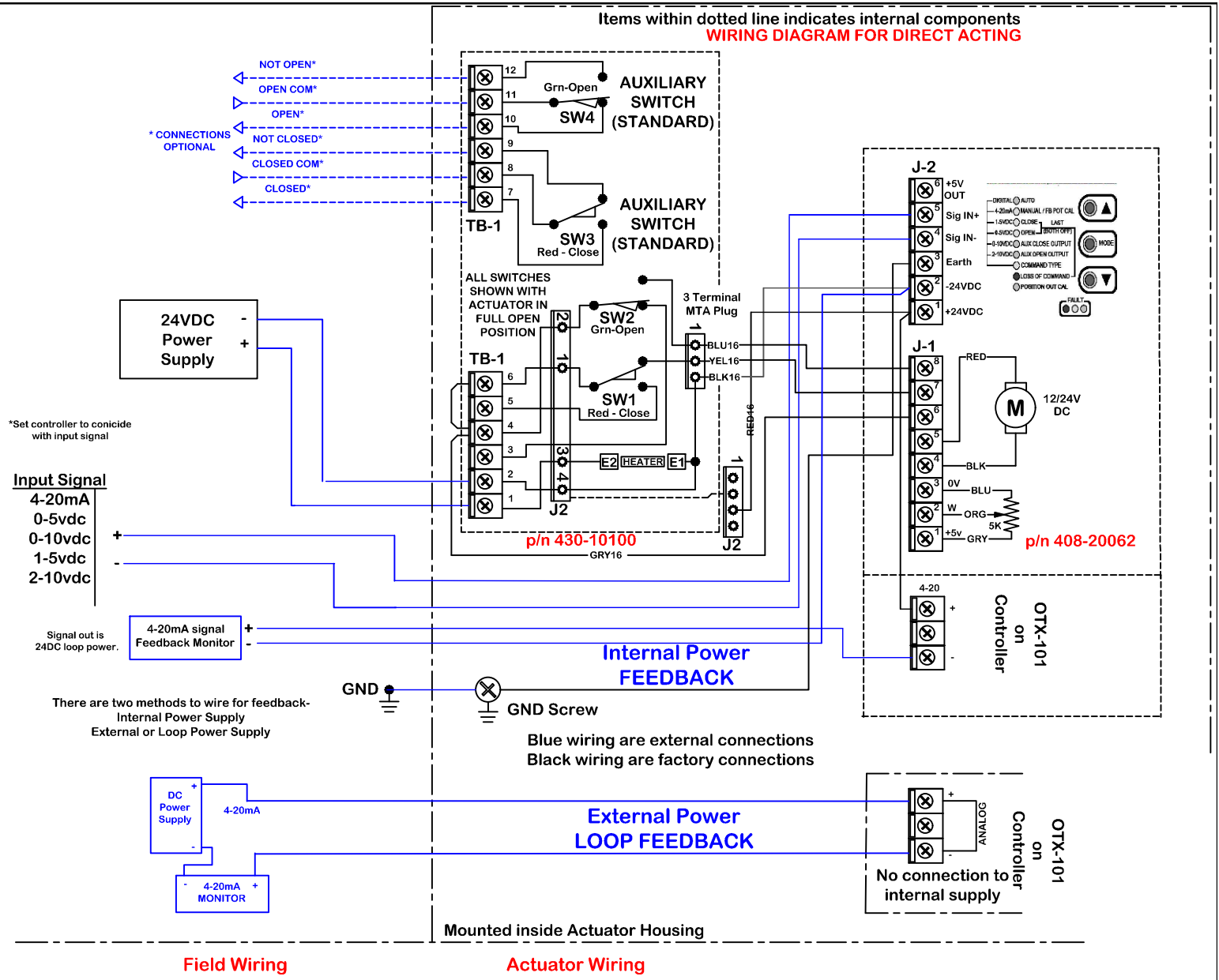

**Actuator ships in fully closed position!**

Use For:

**P2-8 -24PN4(7)-DC**

This document is the property of ProMation Engineering, Inc. Distribution of this document without the written consent of the owner is strictly forbidden. Failure to comply will incur a liability for damages.