

rev	change	date	revision	name	1/13/2020 1:59 PM
h				naming	
g				dwn by:	Date
f				BJW	4.23.2015
e	06.23.17	06.23.17	Added 17' to products changed to p2-8	scale	NONE
d	06.23.17	06.23.17	Removed DC only wiring		
c	05.22.17	05.22.17	changed to +4VDC w/ AD & DC versions		
b	01.28.17	01.28.17	changed to +4VDC		
a	02.03.16	02.03.16	Hot switching, AC or DC updated files (replaces 2101 and 20101 files)		
rev	change	date	revision	name	1/13/2020 1:59 PM
h				naming	
g				dwn by:	Date
f				BJW	4.23.2015
e	06.23.17	06.23.17	Added 17' to products changed to p2-8	scale	NONE
d	06.23.17	06.23.17	Removed DC only wiring		
c	05.22.17	05.22.17	changed to +4VDC w/ AD & DC versions		
b	01.28.17	01.28.17	changed to +4VDC		
a	02.03.16	02.03.16	Hot switching, AC or DC updated files (replaces 2101 and 20101 files)		
rev	change	date	revision	name	1/13/2020 1:59 PM
h				naming	
g				dwn by:	Date
f				BJW	4.23.2015
e	06.23.17	06.23.17	Added 17' to products changed to p2-8	scale	NONE
d	06.23.17	06.23.17	Removed DC only wiring		
c	05.22.17	05.22.17	changed to +4VDC w/ AD & DC versions		
b	01.28.17	01.28.17	changed to +4VDC		
a	02.03.16	02.03.16	Hot switching, AC or DC updated files (replaces 2101 and 20101 files)		

ProMation

WD-850-PA101 E

Wiring Diagram for 2 position or Jog Control. P2/8 Series 24AC or VDC Actuators, Positive Switched.

REV **E**

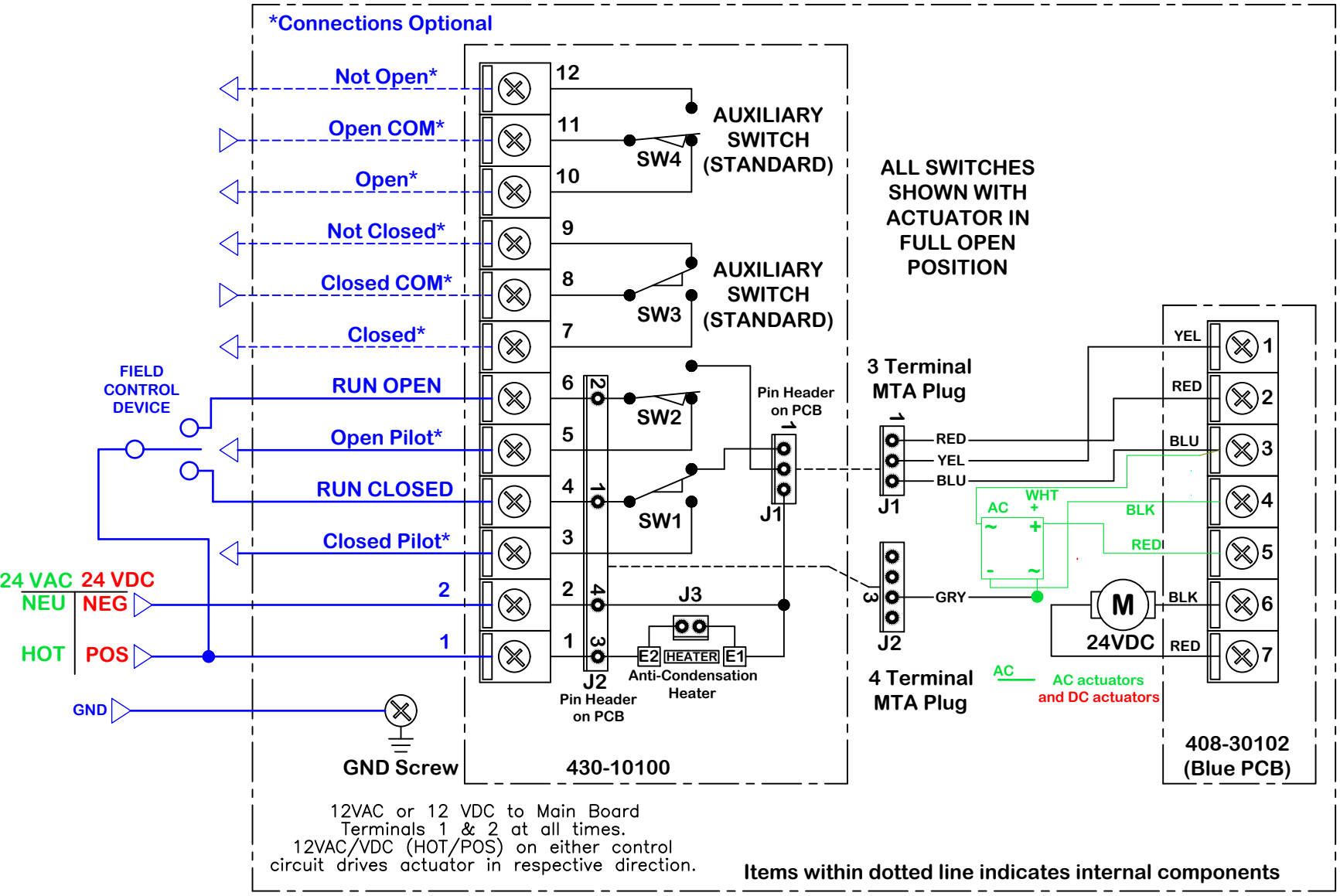

Use For:

P2/8-24N(4,7)+ACDC

Actuator ships in fully closed position!

This document is the property of ProMation Engineering, Inc. Distribution of this document without the written consent of the owner is strictly forbidden. Failure to comply will incur a liability for damages.

ProMation Engineering, Inc.
16138 Flight Path Drive
Brooksville, FL 34604
Ph:352-544-8436 Fx(352-544-8439)