

rev	change date	revision	name	material no	ind	Wiring Diagram
d						
c						
b						
a						
h			norming			
g				dwn by: PMR	Date: 11.22.19	
f						
e				scale: NONE		
d						
c						
b						
a						
REV						<b>D</b>
<b>Promation</b> 11.22.19 P:\C CAD Files\Factory Wiring Dwgs\WD-All CAD Files\WD-850\pz-3 (2-8)						
Wiring Diagram for 2 position or Jog Control, P2-8 Series 24AC or VDC Actuators, Positive Switched.						
<b>WD-850-PAZ01</b>						
ProMation Engineering, Inc. 16138 Flight Path Drive Brooksville, FL 34604 Ph:352-544-8436 Fx:352-544-8439						

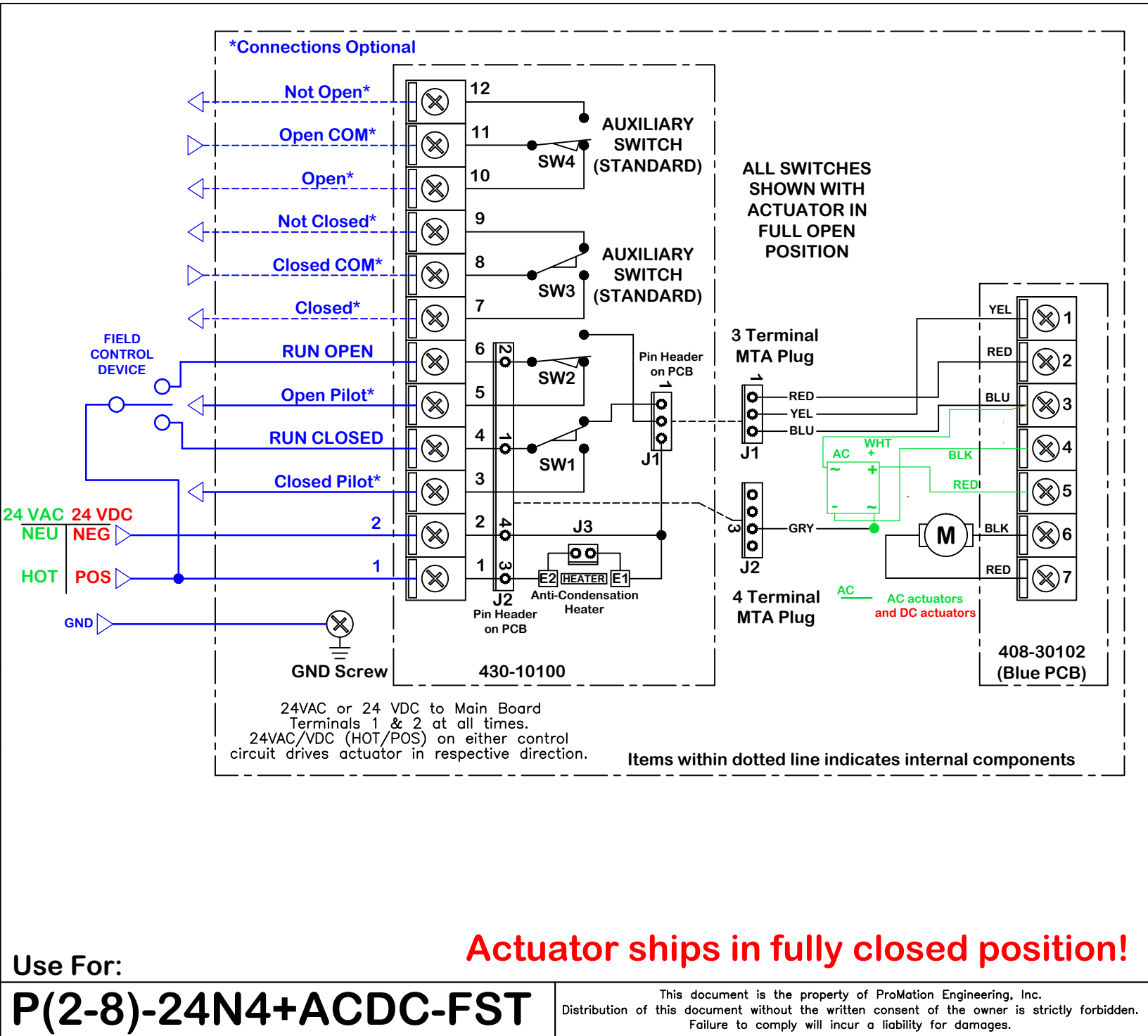

Use For:

**P(2-8)-24N4+ACDC-FST**

This document is the property of ProMation Engineering, Inc. Distribution of this document without the written consent of the owner is strictly forbidden. Failure to comply will incur a liability for damages.