

PROMATION ENGINEERING

Precision Actuation for Industry

Installation & Operation Manual

This IOM is for the following
ProMation Engineering Products:

PBU600-24AP-4

PBU602-24AP-4

PBU604-24AP-4

PBU606-24AP-4

24VAC Proportional



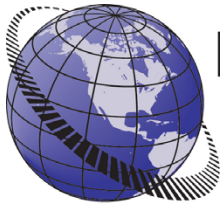

- Provides Fail-Safe Operation for 24v ProMation P Series Industrial Electric actuators sizes P1 through P8 and PL Series Linear actuators
- Field Selectable Fail Direction
- Readily available sealed Battery packs
- Provides up to 500% of Power requirements for a full load cycle (250% on PL Series @ max stroke)
- Lockable Fiberglass NEMA 4X enclosure



The battery backup system (PBU) is housed in a NEMA 4X enclosure with a clear front access door to allow instantaneous visual confirmation of the operation of the system. A 24v torroidal transformer is mounted to the backplane of the cabinet to provide 24vac power to the actuators. This product requires a 120vac supply to power the backup unit.

Table of Contents

| | |
|-----------|--------------------------------------|
| Pg 2 | Product shipping information |
| Pgs 2-3 | Installation notes |
| Pg 4 | Sizing and Performance Data |
| Pg 4 | Sequence of Operation |
| Pg 5 | Wiring diagrams P1, P1.A |
| Pg 6 | Wiring diagrams P2~P8 |
| Pg 7 | Wiring diagrams PL Series |
| Pg 8 | Multiple Actuator Wiring |
| Pg 9 | Mounting & Mechanical data |
| Pgs 10-11 | Electrical Data, Physical Dimensions |
| Pg 12 | Commissioning |
| Pgs 13-14 | Troubleshooting |

Product shipping information:

1. The PBU system is shipped in two separate enclosures. This is done to prevent shipping damage to both the fiberglass enclosure as well as to sensitive components associated with the heavier control panel and battery back up system.
2. BOX 1 contains the fiberglass enclosure. Do NOT use sharp objects when opening the carton as you may damage the clear lexan door attached to the enclosure cabinet.
3. BOX 2 contains the main face plate panel, battery system and control electronics.
4. **This unit is shipped with the battery system disconnected. Follow the instructions below to correctly reconnect the battery to the power unit. Failure to follow the connection sequence will prevent the battery unit from starting.**

Product installation:

1. Remove the cabinet backplane with the toroidal transformer from the cabinet by removing the four corner hex standoffs. Mount the cabinet either indoors or outdoors protected from direct sunlight or other high heat sources. The cabinet mounts with the latches to the RIGHT, and hinge to the LEFT. The suggested EMT entry location is shown on page 9 in the dimensional drawing. Make all conduit penetrations per local code and perform all wire pulls prior to installing the main control panel (see mounting data on page 9).
2. After the enclosure is properly mounted, install the cabinet backplane including the toroidal transformer using the four corner standoffs removed in step 1. DO NOT OVERTIGHTEN!
3. Turn the main panel over to reveal the back side of the plate. Remove the sliding battery compartment cover from the APC unit.
4. Tilt the entire assembly to slide the battery out of the enclosure. This will give you access to the battery terminals.
5. **Connect the battery.** Connect the positive (red) wire to the red battery terminal. Connect the negative (black) wire to the black battery terminal.
6. Slide the battery back into the enclosure, and replace the slide cover. Careful not to pinch the battery wires in the process.
7. Set the signal select DIP switch for the proper signal response. (1 ON = 2-10vdc, 1 OFF = 4-20mA) (**DEFAULT IS SET FOR 4-20mA**).

one of four standoffs



This switch MUST be positioned correctly before mounting the panel into the main enclosure... it is NOT accessible after the panel is mounted.

8. Connect the transformer pigtail to the front panel assembly. This is a polarized plug-in male/female connector. Be sure to match both ends before pressing together to hear the "click".



9. Install the panel onto the four standoff posts from step 2 (above) using 10-32 x 1/2" PH screws from parts bag.
10. Make wiring connections (see pages 5-8). After power is applied to the PBU, press the "Enable" button on the front panel to start the system.

START

Installation and Application Notes:

After installation and wiring are complete, apply power and PRESS the START button to enable the battery system.

Place the FAIL POSITION SELECTOR switch in the desired mode (Fail OPEN or Fail CLOSED) based on the requirements of the site.

Indicator lamps show when Power is applied, which Fail position has been selected, when the Battery is Charging, and when the system is running on Battery Power.

Indicator lenses unscrew to access the lamps. Lamps are T-2 style and PRESS straight in, do NOT twist. Lamps are 120v for 24v & 120v models, and 230v for 230v models.

After the battery has been connected to the power unit, there is LIVE voltage present on the back of the main panel even after the main power has been disconnected. Handle appropriately!

Overloading the backup system will TRIP the breaker. This is a PRESS to RESET type and is NOT self resetting.

It is possible to connect multiple proportional control actuators to a single PBU PROVIDED THE TOTAL ACTUATOR DEMAND DOES NOT EXCEED THE RATING OF THE PBU. Reference page 8 for details.

FM15 PBU 24v Proportional Series Rev H 091415

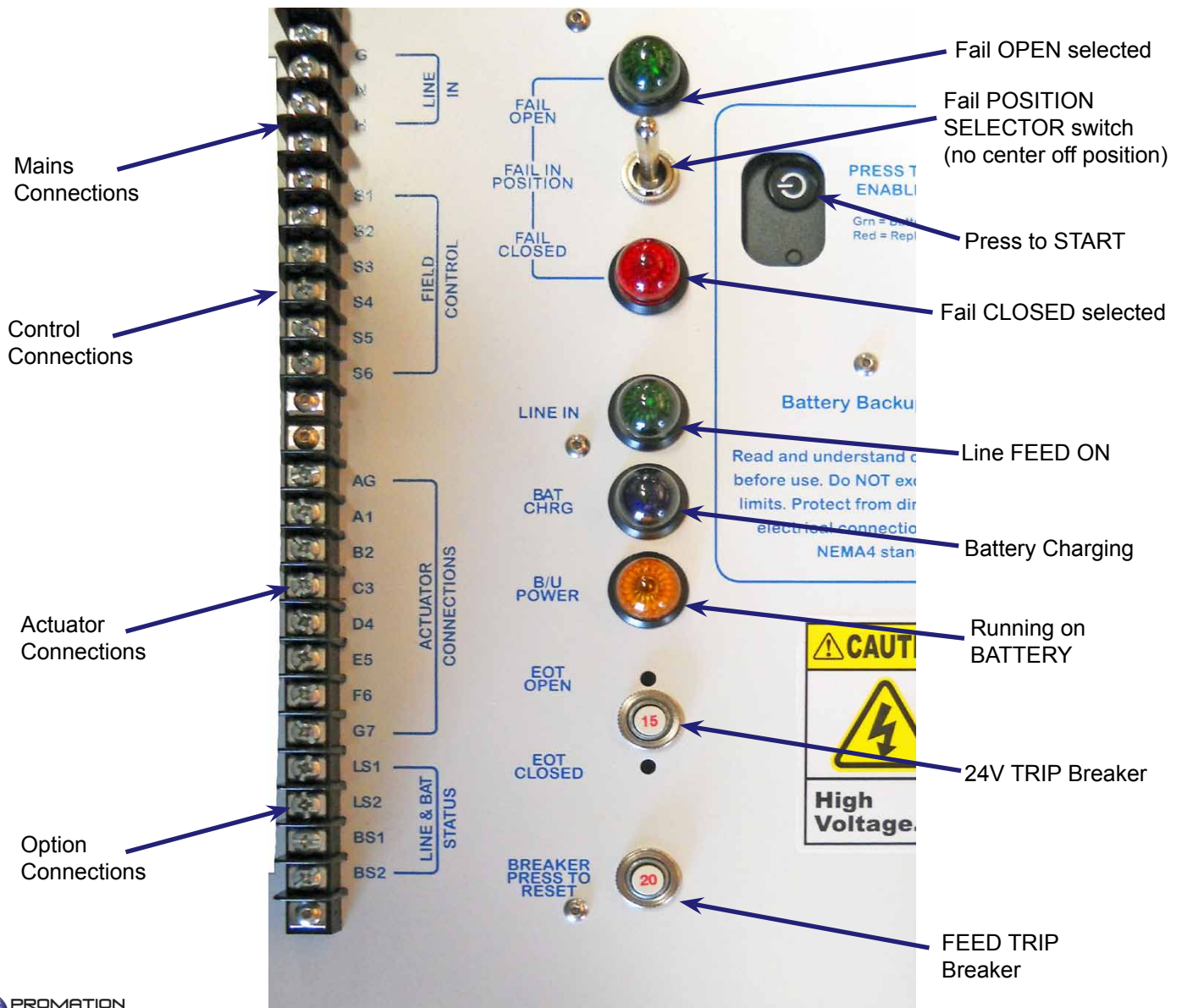

P Series Sizing and Performance Chart - Proportional Actuators

| Actuator | Torque Output | Runtime (Seconds) | Current Draw (Amps) | PBU Model 2-10vdc/4-20mA | Capacity Used @ Full Runtime | Replacement Battery |
|-------------|---------------|-------------------|---------------------|--------------------------|------------------------------|---------------------|
| P1-24PN4 | 300 | 15 | 1.1 | PBU600-24AP-4 | 1.4% | RBC-35 |
| P1.A-24PN4 | 300 | 15 | 1.1 | PBU600-24AP-4 | 1.4% | RBC-35 |
| P2-24PN4-AC | 800 | 15 | 2.2 | PBU600-24AP-4 | 1.4% | RBC-35 |
| P3-24PN4-AC | 1335 | 22 | 2.4 | PBU602-24AP-4 | 2.0% | RBC-110 |
| P4-24PN4-AC | 3500 | 16 | 8.5 | PBU602-24AP-4 | 1.9% | RBC-110 |
| P5-24PN4-AC | 4400 | 22 | 7.5 | PBU602-24AP-4 | 2.6% | RBC-110 |
| P6-24PN4-AC | 5800 | 28 | 7.0 | PBU602-24AP-4 | 8.0% | RBC-110 |
| P7-24PN4-AC | 8900 | 46 | 6.8 | PBU604-24AP-4 | 11.2% | RBC-17 |
| P8-24PN4-AC | 13250 | 46 | 8.1 | PBU604-24AP-4 | 9.8% | RBC-17 |

*24v solutions utilize 24v actuators with included 24v transformer, and require a 120vac supply for the PBU system.

PL Series Sizing and Performance Chart - Proportional Actuators

| Actuator | Force (lbs) | Full Stroke (mm) | Running Speed (mm/sec) | Runtime (sec @ 60Hz Full Travel) | Current Draw (Amps) | PBU Model 2-10vdc/4-20mA | Capacity Used @ Full Runtime | Replacement Battery |
|-----------------|-------------|------------------|------------------------|----------------------------------|---------------------|--------------------------|------------------------------|---------------------|
| PL550-24PN4-AC | 550 | 50 | 0.6 | 84 | 0.4 | PBU606-24AP-4 | 7.8% | RBC-35 |
| PL1100-24PN4-AC | 1100 | 50 | 0.6 | 84 | 0.4 | PBU606-24AP-4 | 7.8% | RBC-35 |
| PL2200-24PN4-AC | 2200 | 100 | 0.5 | 200 | 0.3 | PBU606-24AP-4 | 18.5% | RBC-35 |
| PL4400-24PN4-AC | 4400 | 100 | 0.5 | 200 | 0.3 | PBU606-24AP-4 | 18.5% | RBC-35 |

*24v solutions utilize 24v actuators with included 24v transformer, and require a 120vac supply for the PBU system.

PBU Series Sequence of Operation - Proportional Actuators

The back up system is wired in series between the mains power and the actuator. Under normal operation, 120VAC power supplied to the PBU H & N terminals will illuminate the green "**LINE IN**" indicator light, provide power for the toroidal transformer, and provide charging voltage to the battery system. While Mains power is present, the remotely generated analog control signal (either 2-10vdc or 4-20mA) is passed through the PBU and on to the actuator. The actuator will follow that control signal. While under mains power the blue "**BAT CHARGING**" indicator light will illuminate and the yellow "**B/U POWER**" indicator light will be off. While under mains power, the position of the "**FAIL POSITION SELECT**" switch is irrelevant. Power is supplied through the back-up system cabinet and the actuator heater is enabled. No current is being drawn from the battery system during this mode of operation. Optional indicator lights can be wired to show actuator end of travel status. These lamps are active as long as the battery system is running or Mains power is present. Optional STATUS contacts can be used for remote health indicators of LINE voltage coming into the PBU and if the Battery System is operating.

When the mains power is lost, charging power is no longer supplied to the battery system. The green "LINE IN" indicator light is turned off, and the battery system automatically generates modified-sine wave line voltage to provide power for the transformer to generate 24v actuator power. The blue "BAT CHARGING" indicator light is turned off, and the yellow "B/U POWER" indicator light is turned on. The "FAIL POSITION SELECT" switch becomes active, and depending on its position, drives the actuator either fully OPEN or fully CLOSED via its own signal generator. During this mode of operation, the remote analog control signal (if present or not) is irrelevant. The battery system will provide ample power to drive the actuator more than 5 full torque cycles. However, once the actuator reaches its end-of-travel limit switch, power drain from the back-up system is reduced to the requirements of the yellow "B/U POWER" indicator light and the transformer eddy current draw (up to 10% of rated load). After 15 minutes, the battery system turns itself off and waits for the mains power to return. The design of the ProMation P Series actuators provides automatic locking of the actuator position after the battery system shuts down. Normal operation is resumed when mains power returns.

It is possible to connect multiple proportional control actuators to a single PBU PROVIDED THE TOTAL ACTUATOR DEMAND DOES NOT EXCEED THE RATING OF THE PBU. Reference page 8 for details.

PBU600 - 24AN4 P1/P1.A Series Proportional Control 24vac Actuators

The selector switch for 4-20mA or 2-10vdc control is located on the BACK of the PBU main panel.

This switch MUST be positioned correctly before mounting the panel into the main enclosure.

Switch position #1 is OFF (default) for 4-20mA control, and is ON for 2-10vdc control.

The setting of this switch must match that of the actuator as well as the intended FIELD CONTROL DEVICE.



FM15 PBU 24V Proportional Series Rev H 091415

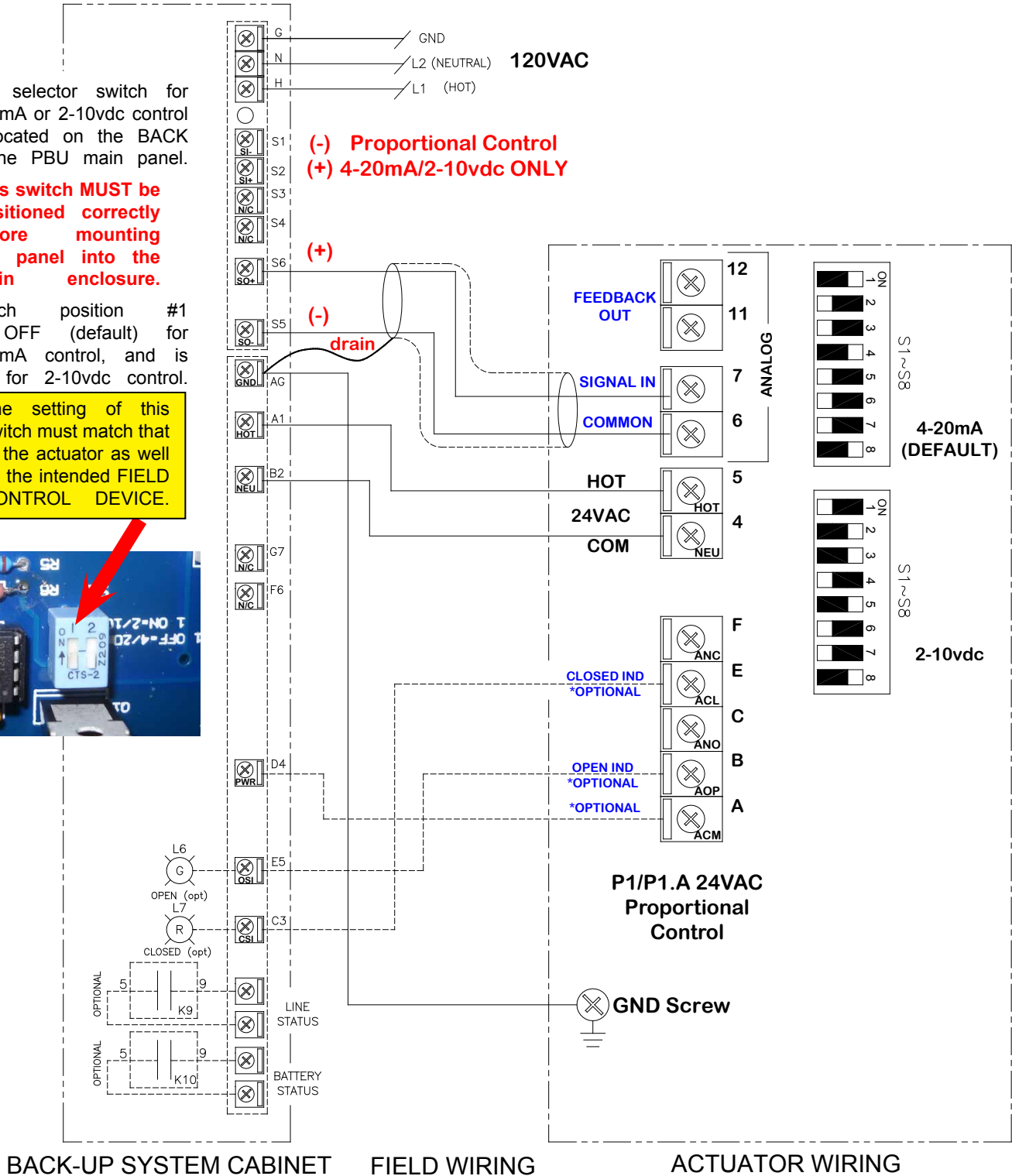

PBU600, 602, 604 - 24AN4 for P2~P8 Series Proportional Control 24vac Actuators

The selector switch for 4-20mA or 2-10vdc control is located on the BACK of the PBU main panel.

This switch MUST be positioned correctly before mounting the panel into the main enclosure.

Switch position #1 is OFF (default) for 4-20mA control, and is ON for 2-10vdc control.

The setting of this switch must match that of the actuator as well as the intended FIELD CONTROL DEVICE.

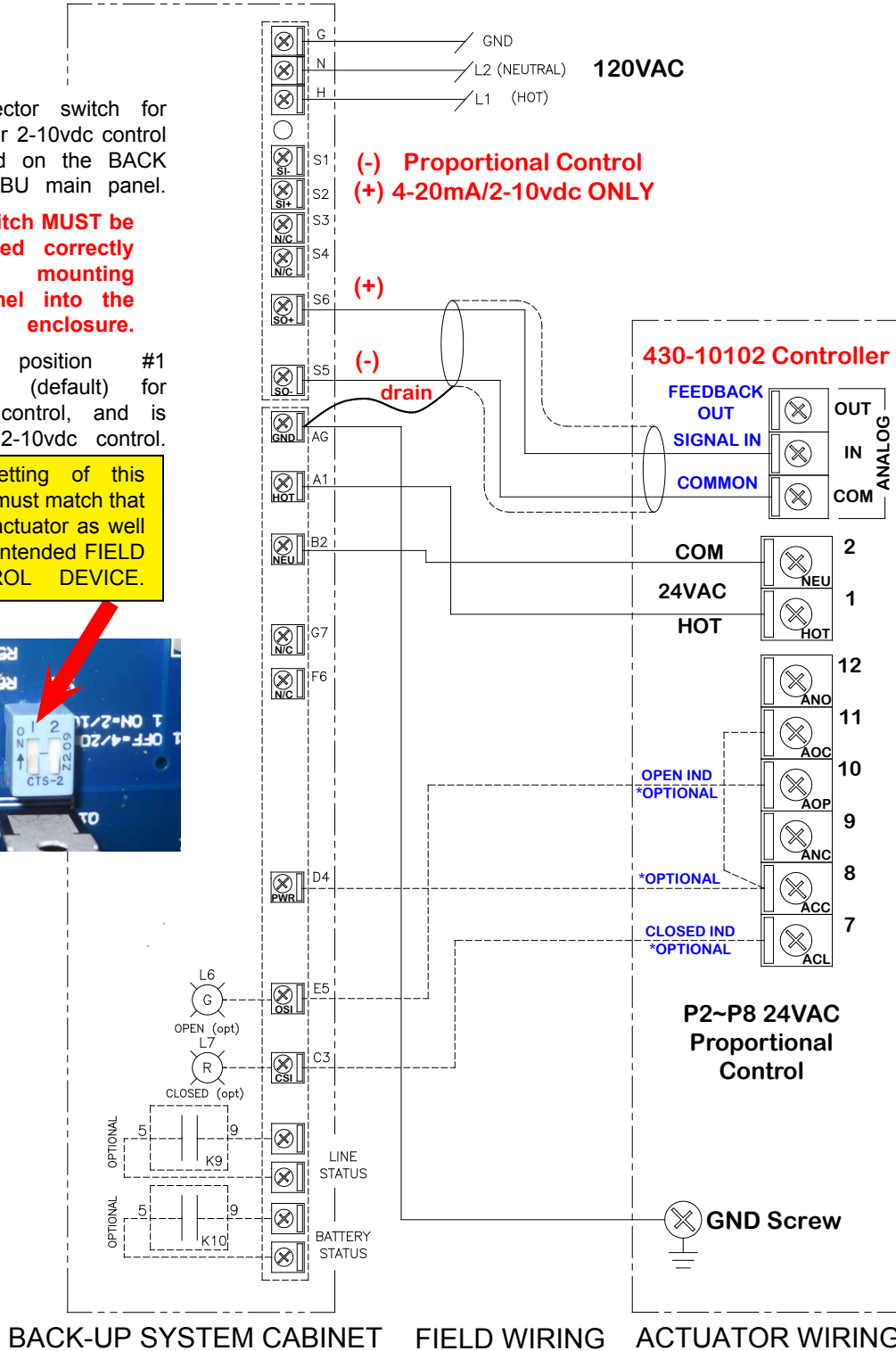

FM15 PBU 24v Proportional Series Rev H 091415

PBU600, 602, 604 - 24AN4 for PL550/1100/2200/4400 Series Proportional Control 24vac Actuators

The selector switch for 4-20mA or 2-10vdc control is located on the BACK of the PBU main panel.

This switch MUST be positioned correctly before mounting the panel into the main enclosure.

Switch position #1 is OFF (default) for 4-20mA control, and is ON for 2-10vdc control.

The setting of this switch must match that of the actuator as well as the intended FIELD CONTROL DEVICE.



FM15 PBU 24V Proportional Series Rev H 091415

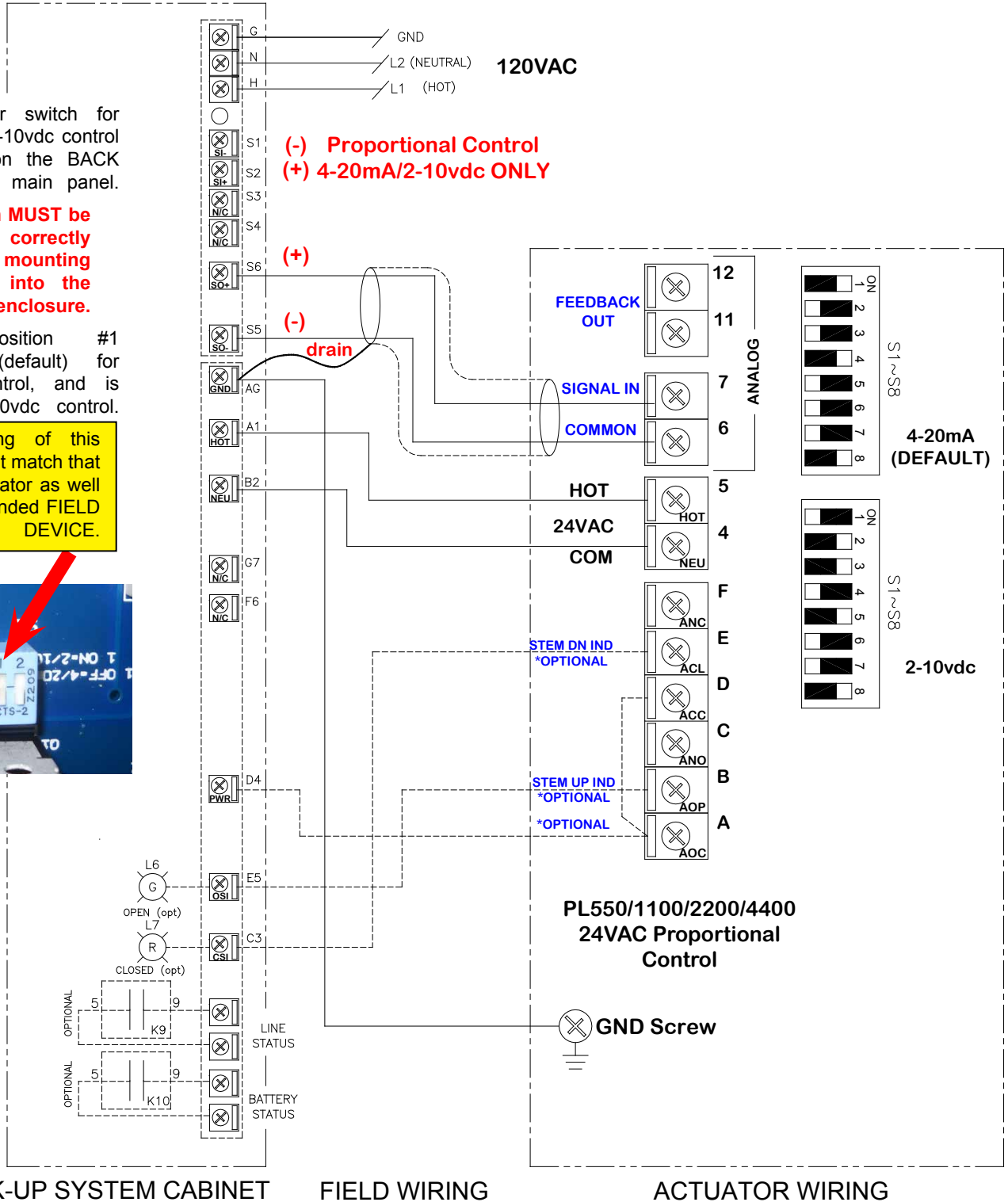

PRECAUTIONS WHEN CONNECTING MULTIPLE PROPORTIONAL CONTROL ACTUATORS TO A SINGLE PBU UNIT.

CAUTION! Check actuator START current demand for each actuator being connected to a single PBU unit. ADD the STARTING currents together, then check the SELECTION TABLES on page 4 to determine which PBU model will support the requirement. Do NOT exceed the rating of the PBU. This will cause premature battery failure, breaker tripping, low actuator torque, and unreliable actuator operation.

IMPORTANT! NOTE that there is only ONE FIELD CONTROL point provided on the PBU. This means any actuator(s) connected to the PBU will be required to OPERATE on the SAME CONTROL LOOP. Actuators may be set to operate in series (4-20mA control), or in parallel (2-10vdc control).

Follow the wiring diagram below (example is 24vac) to connect multiple 4-20mA actuators to a single PBU unit.

PBU600-24APN4 w/ 2x P1-24PN4 shown (4-20mA mode)

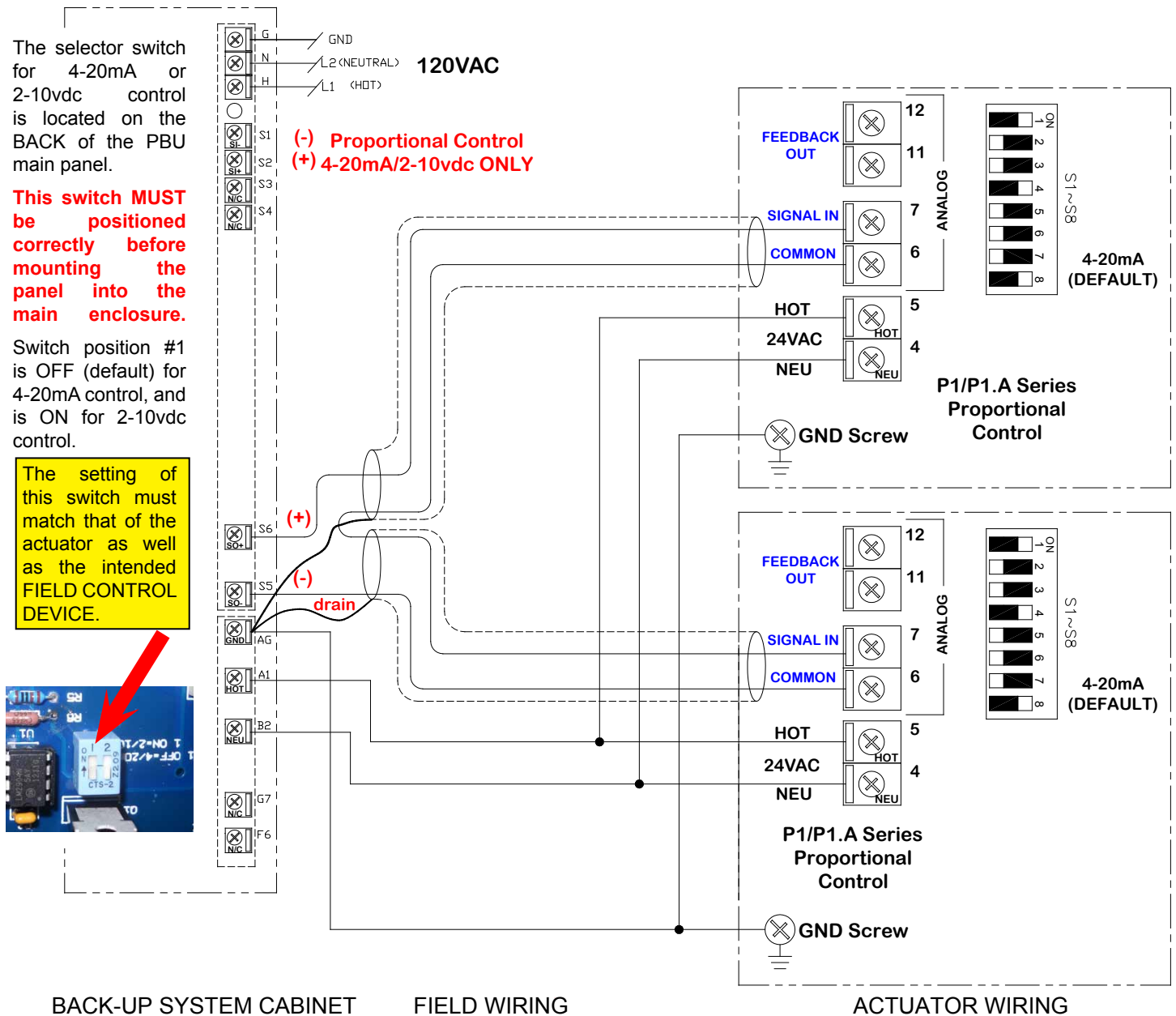

FM15 PBU 24v Proportional Series Rev H 091415

Mounting Dimensional Data

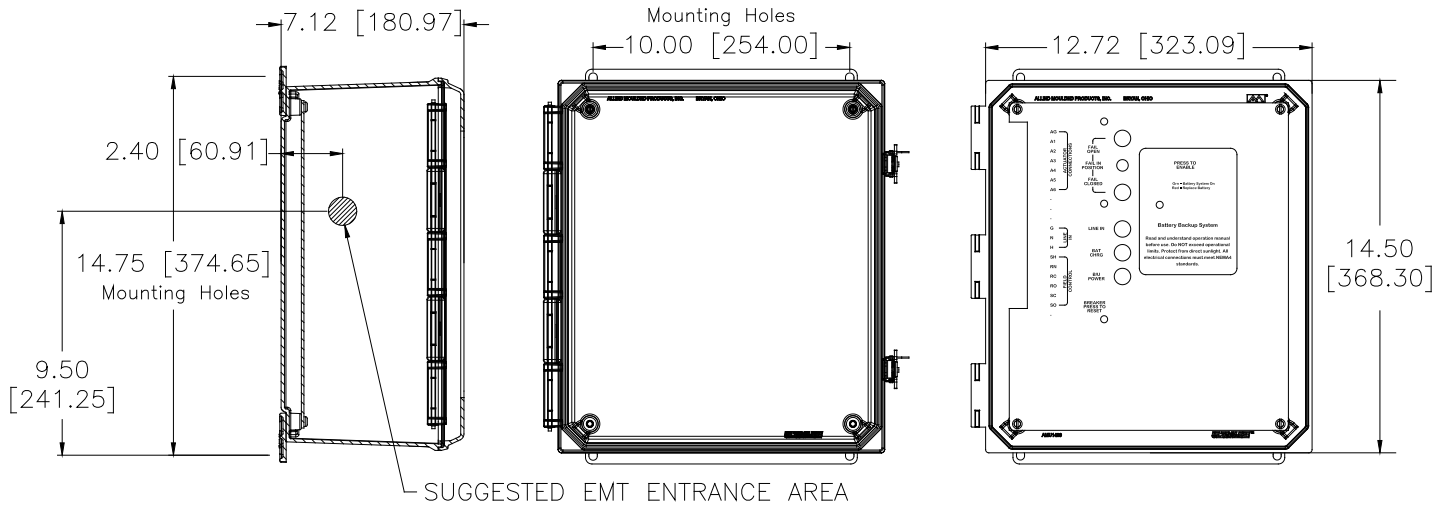

PBU-100, 600

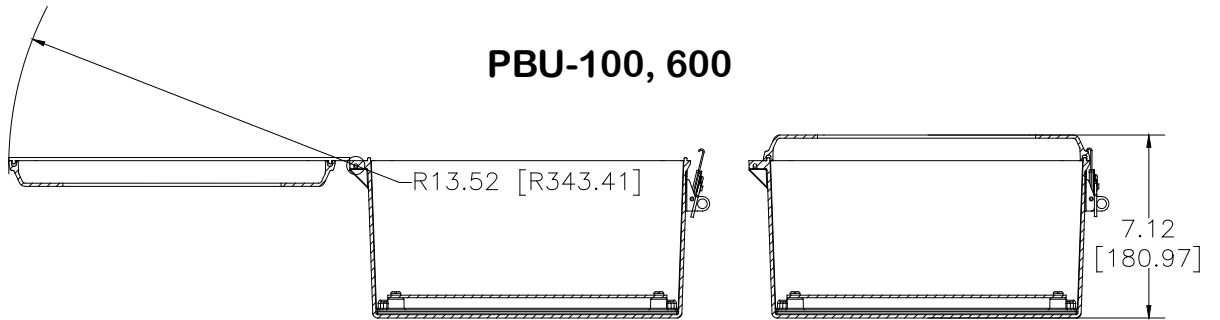

FM15 PBU 24w Proportional Series Rev H 09/14/15

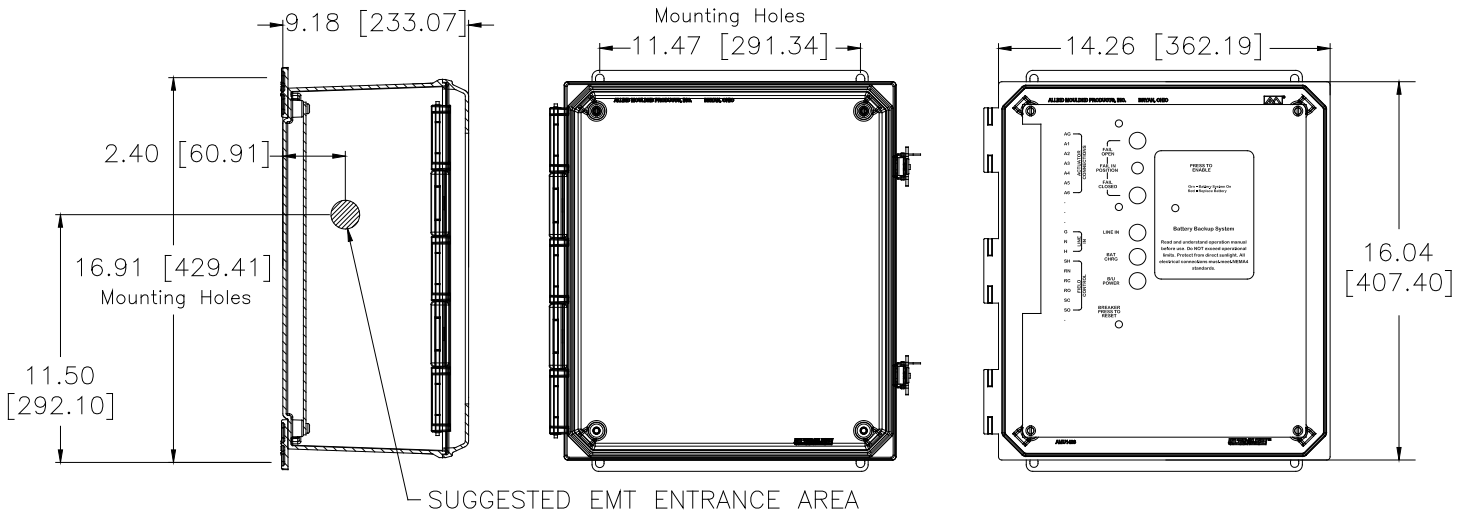

PBU-102, 104, 505, 506, 602, 604, 606

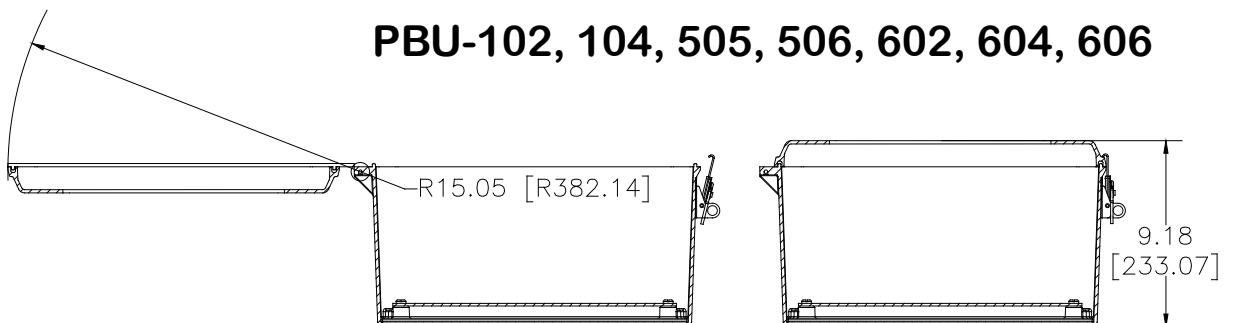

Technical Specifications:

| | | PBU600-120 | PBU600-24 | |
|-------------------|--|--|---------------------|--|
| <u>Input:</u> | Nominal input voltage: Mains Input Voltage Range: | 120vac 88-139vac | 120vac 88-139vac | |
| | Input Frequency: | 50/60Hz +/- 1Hz (auto sensing) | | |
| <u>Output:</u> | Nominal Output voltage: | 120vac | 24vac | |
| | Power Capacity: Waveform Type: | 350VA/ 210 Watts Stepped approximation to a sinewave | | |
| <u>Batteries:</u> | Typical backup time at half-load: Type: | 5.6 minutes Maintenance-Free sealed lead-acid Suspended electrolyte: Leakproof | | |
| | Typical recharge time: | 16 hours ** | | |
| <u>Filtering</u> | Full time multi-pole noise filtering: | 5% IEEE surge let-through. Response time meets UL 1449 | | |

| | | PBU602-120 | PBU602-24 | PBU602-230 |
|-------------------|--|---|---------------------|----------------------|
| <u>Input:</u> | Nominal input voltage: Mains Input Voltage Range: | 120vac 88-139vac | 120vac 88-139vac | 230vac 186-268vac |
| | Input Frequency: | 50/60Hz +/- 1Hz (auto sensing) | | |
| <u>Output:</u> | Nominal Output voltage: | 120vac | 24vac | 230vac |
| | Power Capacity: Waveform Type: | 550VA/ 300 Watts Stepped approximation to a sinewave | | |
| <u>Batteries:</u> | Typical backup time at half-load: Type: | 13.4 minutes Maintenance-Free sealed lead-acid Suspended electrolyte: Leakproof | | |
| | Typical recharge time: | 24 hours ** | | |
| <u>Filtering</u> | Full time multi-pole noise filtering: | 5% IEEE surge let-through. Response time meets UL 1449 | | |

| | | PBU604-120 | PBU604-24 | PBU604-230 |
|-------------------|--|---|---------------------|----------------------|
| <u>Input:</u> | Nominal input voltage: Mains Input Voltage Range: | 120vac 88-139vac | 120vac 88-139vac | 230vac 186-268vac |
| | Input Frequency: | 50/60Hz +/- 1Hz (auto sensing) | | |
| <u>Output:</u> | Nominal Output voltage: | 120vac | 24vac | 230vac |
| | Power Capacity: Waveform Type: | 750VA/ 540 Watts Stepped approximation to a sinewave | | |
| <u>Batteries:</u> | Typical backup time at half-load: Type: | 11.8 minutes Maintenance-Free sealed lead-acid Suspended electrolyte: Leakproof | | |
| | Typical recharge time: | 16 hours ** | | |
| <u>Filtering</u> | Full time multi-pole noise filtering: | 5% IEEE surge let-through. Response time meets UL 1449 | | |

** The time to recharge to 90% of full battery capacity following a discharge to shutdown using a load rated for 1/2 the full load rating of the UPS.

Technical Specifications:

| | | PBU606-120 | PBU606-24 | PBU606-230 |
|-------------------|--|--|---------------------|----------------------|
| <u>Input:</u> | Nominal input voltage: Mains Input Voltage Range: | 120vac 88-139vac | 120vac 88-139vac | 230vac 186-268vac |
| | Input Frequency: | 50/60Hz +/- 1Hz (auto sensing) | | |
| <u>Output:</u> | Nominal Output voltage: | 120vac | 24vac | 230vac |
| | Power Capacity: Waveform Type: | 750VA/ 540 Watts Stepped approximation to a sinewave | | |
| <u>Batteries:</u> | Typical backup time at half-load: Type: Typical recharge time: | 11.8 minutes Maintenance-Free sealed lead-acid Suspended electrolyte: Leakproof 16 hours ** | | |
| <u>Filtering</u> | Full time multi-pole noise filtering: | 5% IEEE surge let-through. Response time meets UL 1449 | | |

Environmental:

Operating Relative Humidity 0 - 95%

Operating Elevation 0-10000 feet (0-3000 m)

Storage Temperature -15 - 45 °C (5 - 113°F)

Storage Relative Humidity 0 - 95%

Storage Elevation 0-50000 feet (0-15000 m)

Audible noise at 1 meter from surface of unit 45 dBA

Online thermal dissipation 14 (100), 16 (102) & 47 (104) BTU/hr

** The time to recharge to 90% of full battery capacity following a discharge to shutdown using a load rated for 1/2 the full load rating of the UPS.

Conformance - APC Back UP Module:

Approvals: cUL Listed
FCC Part 15 Class B
FCC part 68, NOM
UL1778
UL497A
UL498

Physical Dimensions PBU Series Back Up Systems

| | PUB 100/600 | | PBU 102/602 | | | PBU 104/505/506/604/606 | | |
|-----------|-------------|-------|-------------|-------|-------|-------------------------|-------|-------|
| VAC | 120 | 24 | 120 | 24 | 230 | 120 | 24 | 230 |
| Max HT | 15.25 | 15.25 | 17.50 | 17.50 | 17.50 | 17.50 | 17.50 | 17.50 |
| Max WD | 13.52 | 13.52 | 15.05 | 15.05 | 15.05 | 15.05 | 15.05 | 15.05 |
| Net Depth | 7.50 | 7.50 | 9.50 | 9.50 | 9.50 | 9.50 | 9.50 | 9.50 |
| Net WT | 35 | 45 | 45 | 58 | 50 | 54 | 72 | 58 |
| Ship WT | 45 | 55 | 58 | 71 | 63 | 67 | 85 | 71 |

*NOTE: PBU Series ships in two separate cartons.

Commissioning:

After completing all mounting and wiring procedures, main power is available and battery has been connected per instructions found on page 2, it is now possible to commission the PBU.

1. Apply power to the unit, the green LINE IN indicator is illuminated.
2. Measure (for your unit) xxx vac on terminals H & N on the PBU panel face.
 - 2.01 PBU 120V & 24V units, measure 100-125vac on terminals H & N on the PBU panel face.
 - 2.02 PBU 230V units, measure 210-240vac on terminals H & N on the PBU panel face.
3. Press the START button on the battery unit (see item 10 page 2).
4. Wait for 30 seconds, then the LED on the battery unit itself will turn green and stay on solid.
5. Measure (for your unit) xxx vac on terminals A1 & B2 on the PBU panel face.
 - 5.01 PBU 120V units, measure 100-125vac on terminals A1 & B2 on the PBU panel face.
 - 5.02 PBU 24V units, measure 22.5-26.0vac on terminals A1 & B2 on the PBU panel face.
 - 5.03 PBU 230V units, measure 210-240vac on terminals A1 & B2 on the PBU panel face.
6. The blue CHARGE indicator is illuminated.
7. The yellow BAT POWER indicator is NOT illuminated.
8. Command the FIELD CONTROL DEVICE to generate a CLOSE signal (4mA or 2vdc). The actuator will drive CLOSED.
9. Measure 4mA (2vdc) between terminal S5 (-) and S6 (+) {actuator disconnected}.
10. Command the FIELD CONTROL DEVICE to generate an OPEN signal (20mA or 10vdc). The actuator will drive OPEN.
11. Measure 20mA (10vdc) between terminal S5 (-) and S6 (+) {actuator disconnected}.
12. Move the Fail Position Selector switch to the OPEN position, and the green FAIL OPEN indicator is illuminated. This will have no effect on the position of the ACTUATOR.
13. Move the Fail Position Selector switch to the CLOSE position, and the red FAIL CLOSED indicator is illuminated. This will have no effect on the position of the ACTUATOR.
14. Disconnect MAIN power from the PBU.
15. The ALARM will start beeping on the battery unit, once every 30 seconds until power is restored.
16. The green LINE IN indicator will turn off.
17. The blue BAT CHARGE indicator will turn off.
18. The yellow BAT POWER indicator will be illuminated.
19. The commands received from the FIELD CONTROL DEVICE will have no effect on the positioning of the actuator.
20. Measure 0 vac on terminals H & N (all models).
21. Measure (for your unit) xxx vac on terminals A1 & B2 on the PBU panel face.
 - 21.01 PBU 120V units, measure 100-125vac on terminals A1 & B2 on the PBU panel face.
 - 21.02 PBU 24V units, measure 22.5-26.0vac on terminals A1 & B2 on the PBU panel face.
 - 21.03 PBU 230V units, measure 210-240vac on terminals A1 & B2 on the PBU panel face.
22. Move the Fail Position Selector switch to the CLOSE position, the red FAIL CLOSE indicator is illuminated and the actuator will drive CLOSED. The FIELD CONTROL DEVICE will have no effect on the position of the actuator in this mode.
23. Measure 4mA (2vdc) between terminal S5 (-) and S6 (+) {actuator disconnected}.
24. Move the Fail Position Selector switch to the OPEN position, the green FAIL OPEN indicator is illuminated and the actuator will drive OPEN. The FIELD CONTROL DEVICE will have no effect on the position of the actuator in this mode.
25. Measure 20mA (10vdc) between terminal S5 (-) and S6 (+) {actuator disconnected}.
26. Reconnect actuator control wires.
27. Re-establish Main power, whereupon the unit will automatically return to normal operating mode.
28. Unit is now ready for automatic operation.

Troubleshooting - Proportional Control Units

Common questions when using ProMation Engineering PBU systems:

| Issue: | Check: |
|---|---|
| The green LINE IN indicator does not illuminate. | Measure for proper line voltage on terminals H & N on the panel face. Check the indicator bulb. |
| The green start indicator on the internal battery system does not turn on when the start button is pressed. | Measure for proper line voltage on terminals H & N on the panel face. Is the battery connected as instructed on page 2? Has the panel breaker(s) tripped? Check the indicator bulb on the panel face. Check the status indicator adjacent to the START button. Other than solid green color indicates a system problem. |
| The blue charge indicator does not illuminate. | Has the START button been pressed? Has the battery been connected as instructed on page 2? Check the indicator bulb. |
| The yellow BATTERY B/U indicator does not illuminate. | Has the START button been pressed? Has the battery been connected as instructed on page 2? Has line voltage been removed from terminals H & N? Has the panel breaker(s) tripped? Check the indicator bulb. |
| The breaker keeps tripping. | Check for proper actuator and PBU supply wiring and correct input voltage. Check thermal temperature of panel face. |
| The connected actuator does not respond properly to FIELD CONTROL Signals under MAIN POWER. | Has the toroidal transformer connection been completed inside the PBU enclosure? Has the START button been pressed? Has the battery been connected as instructed on page 2? Has the panel breaker(s) tripped? Check FIELD CONTROL DEVICE (FCD) wiring to PBU terminals S1 & S2 compared to wiring diagrams in this manual. Disconnect actuator control wiring from S5 & S6 and measure mA or vdc at those terminals. The measurement must match that generated by the FCD. Polarity MUST be correct at S1 & S2, and at S5 & S6. Reconnect actuator control wiring and measure correct control signal and polarity AT THE ACTUATOR. Check actuator response settings. |

FM15 PBU 24V Proportional Series Rev H 09/14/15

Troubleshooting - Proportional Control Units

(continued):

| | |
|--|--|
| <p>The connected actuator does not respond properly in battery backup mode.</p> | <p>Has the START button been pressed? Has the battery been connected as instructed on page 2? Has line voltage been removed from terminals H & N? Has the panel breaker(s) tripped? Does the actuator respond correctly in POWER mode? Has the FAIL Position switch been set properly? Disconnect actuator control wiring from S5 & S6 and measure mA or vdc at those terminals. When the FAIL position is selected for OPEN, S5 to S6 must read 19.9mA (9.95vdc) or greater. When the FAIL position is selected for CLOSED, S5 to S6 must read 3.9mA (1.95vdc) or less. Polarity MUST be correct at S5 & S6. Reconnect actuator control wiring and measure correct control signal and polarity AT THE ACTUATOR. Check actuator response settings.</p> |
| <p>The connected actuator does not drive completely to the selected fail position before stopping.</p> | <p>Check the status indicator adjacent to the START button. Other than solid green color indicates a system problem. The battery may need replacing. Check product selection tables for proper actuator / PBU sizing. Measure the running current between PBU terminal A1 and actuator terminal 1 while running to check for abnormally high current readings. Seating torques may have increased over time to exceed the capability of the actuator and/or PBU system.</p> |
| <p>Multiple actuators connected to the same unit do not drive to the intended fail position.</p> | <p>Do the total starting amps of all the actuators together exceed the rating of the PBU? Has the wiring diagram on page 8 been followed?</p> |
| <p>There is no change in the status contacts when the PBU changes operating modes from POWER to BATTERY.</p> | <p>Unless ordered WITH the STATUS option, those PBU terminals are not activated on standard PBU models.</p> |

For further assistance, please contact:

ProMation Engineering, Inc.
352-544-8436 Technical Support
www.promationei.com

Before contacting technical assistance, please have available your model number, serial number, and SO number, all found on the product label inside the PBU unit, as well as an as-built wiring diagram of your installation.

ProMation Engineering follows a policy of continual product updates and enhancements. Please use the scan code on the back of this document to easily navigate to, or go on-line to our website to obtain the latest product documentation.





PROMATION ENGINEERING

Precision Actuation for Industry

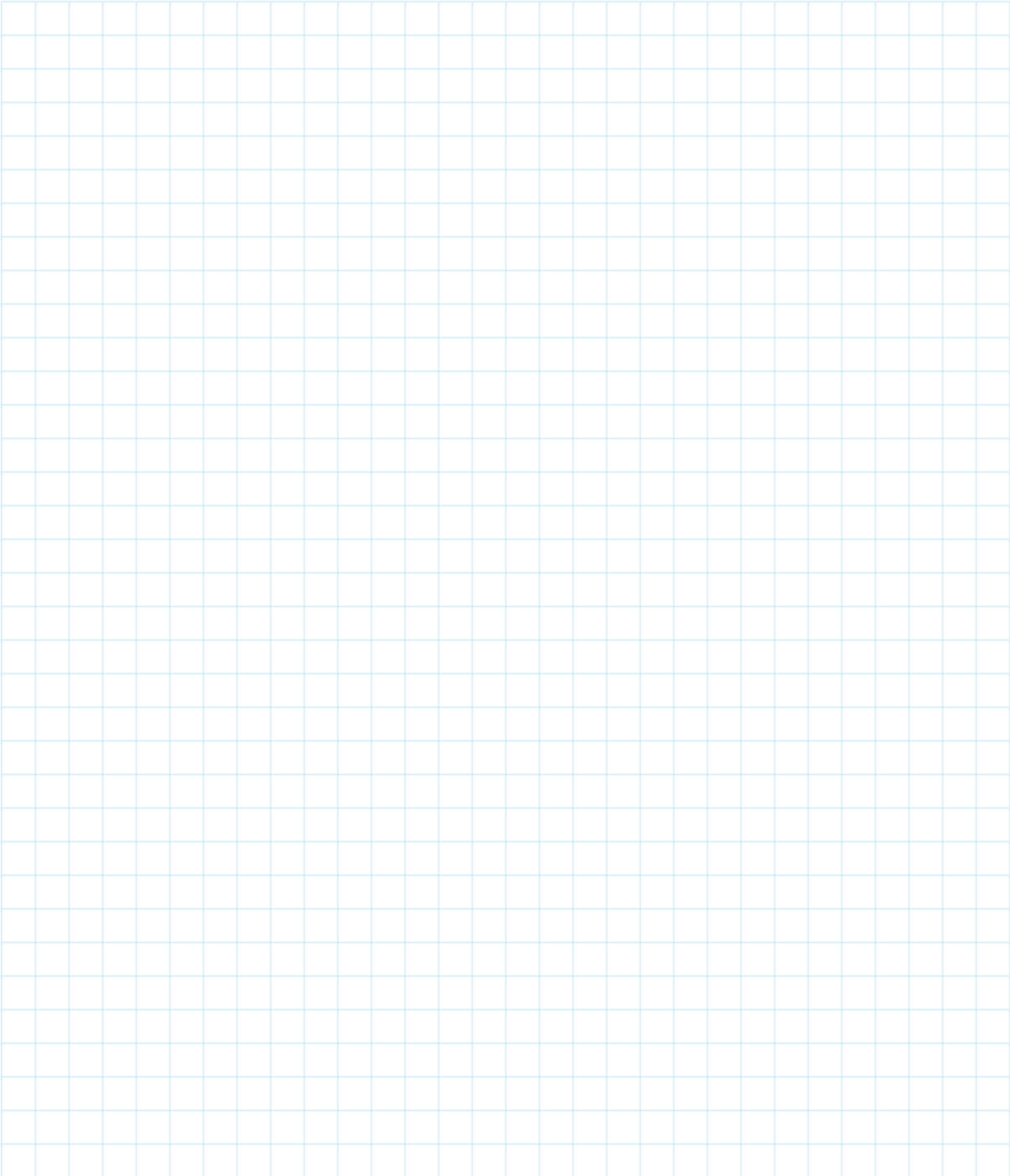

Industrial Applications

ProMation Engineering actuators have been installed to operate process controls such as butterfly valves, ball valves, high performance valves, plug valves, gate valves and dampers, in a broad range of demanding industrial applications.

**Power
Generation**



**Water
Processes**



Mining



Oil and Gas



Agriculture

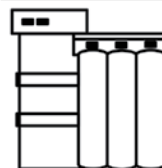

Chemicals



Complete Support

ProMation Engineering is committed to providing superior customer support for your sales, project management and installation teams. Contact us today.

Full Documentation

We offer complete wiring diagrams, field installation manuals and set up documentation for all our products, both in printed and digital form. We regularly host customized educational webinars for our customers.

RapidQuote

Most quotes and estimates are generated within hours of the request.

ProMation Engineering Services

ProMation Engineering can provide design and technical services for OEM's, projects with customized requirements and specialized operations.

ProMation Engineering follows a policy of continual product updates and enhancements. Our website is the best place to obtain the latest product documentation, including the wiring diagrams for these controllers. Visit us at www.promationei.com or use the code to link to the site.



**PROMATION
ENGINEERING**

Precision Actuation for Industry

16138 Flight Path Drive
Brooksville, FL 34604

Phone (352) 544-8436 Fax (352) 544-8439
email: sales@promationei.com



Use your smart phone barcode scanner app here.