

# PROMATION ENGINEERING

*Precision Actuation for Industry*

## Installation & Operation Manual

This IOM is for the following  
ProMation Engineering Products:

**PAO-CW-233PS4**

**PAO-CW-383PS4**

**PAO-CW-443PS4**

**PAO-CW-483PS4**

## Spring Return Theory of Operation

From the Spring CW position (UNLOADED), power is connected to terminals. While power is present, the actuator will respond to drive control signals depending on the model chosen.

- **A 2 position unit** will drive until it reaches its LOADED position (opposite the spring return direction).
- **A Proportional control unit** will follow an analog control signal for positioning and will HOLD until a modified control signal is received.
- **In each of these models** a motor brake unit is utilized to HOLD the actuator in position until commanded to move OR a loss of supply voltage.

**If power is lost or removed at any time, the brake is released and the mechanical spring mechanism returns the actuator to its UNLOADED position. Once the spring mechanism has been released, the actuator will not drive under power again until:**

- a) The unit has reached its UNLOADED position AND
- b) Power has been restored to the actuator AND
- c) Initial Power Startup delay of several seconds has elapsed.

**While the actuator is UNLOADED, the manual handwheel may be employed to position the actuator anywhere between the UNLOADED and LOADED position, and the actuator will HOLD in that position indefinitely, regardless of whether power is applied.**

- The manual handwheel must return the actuator to its UNLOADED position BEFORE electrical operation of the actuator will be possible. ***This is a safety feature.***
- If the actuator has been driven electrically to its LOADED position, the manual handwheel cannot be used to drive the actuator back to its UNLOADED position. ***This safety feature*** prevents the unexpected release of stored spring energy.
- Remote indication of actuator status can be accomplished by utilizing built-in auxiliary switches. These dry-contact form C switches will show when an actuator has been overridden after power has been restored, indicating the actuator will NOT operate under control again until it has been manually returned to the UNLOADED position (explained above).

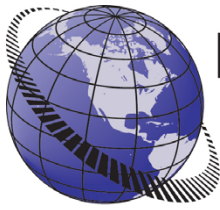

# PROMATION ENGINEERING

Precision Actuation for Industry

## Field Manual PAO-CW 3Phase PS4 CW Spring Return w/ Manual Override Proportional Control ISO5211 F07 8P17



FM15\_PAO CW 3ph PS4 Ver G 072015

### Table of Contents

|    |   |
|----|---|
| ii | Spring Return Theory of Operation             |
| 2  | Product Specifications                        |
| 3  | Shipping and Handling                         |
| 3  | Product Mounting and Setup                    |
| 3  | Installation Notes                            |
| 4  | Wiring Diagram                                |
| 5  | Layout of controller                          |
| 5  | Product Mounting and Setup                    |
| 6  | Adjusting the actuator End-Stop position      |
| 7  | Adjusting the actuator Cam positions          |
| 8  | Recalibration of Proportional Controller      |
| 8  | Adjusting the actuator Auxiliary Switches     |
| 9  | Mechanical Data                               |
| 10 | Mechanical Data                               |
| 11 | Commissioning                                 |
| 12 | Troubleshooting                               |
| 13 | Spring Return Manual Override Orientation -CW |

## Product Specifications

| Actuator Specifications             | PAO   |           |           |           |
|-------------------------------------|---|-----------|-----------|-----------|
| Torque "lb/Nm                       | 445"lbs/50Nm  |           |           |           |
| Supply Voltage                      | 230vac 3Ø   | 380vac 3Ø | 440vac 3Ø | 480vac 3Ø |
| Max Inrush Current                  | 1.04A   | 0.63A     | 0.55A     | 0.50A     |
| Running Current                     | 0.52A   | 0.32A     | 0.27A     | 0.25A     |
| Motor                               | Split Phase Capacitor   |           |           |           |
| Runtime (90°@60Hz)                  | 7 sec   | 7 sec     | 7 sec     | 7 sec     |
| Runtime (90°@50Hz)                  | 9 sec   | 9 sec     | 9 sec     | 9 sec     |
| Runtime (spring)                    | 3 sec   | 3 sec     | 3 sec     | 3 sec     |
| Duty Cycle                          | 50%   |           |           |           |
| Motor Starts                        | 300 per hour  |           |           |           |
| Weight                              | 88lbs/40kg (add 12lbs/5.5kg for LCS)                                    |           |           |           |
| Mechanical Connections              | ISO5211 F07 8pt 17mm  |           |           |           |
| Electrical Entry                    | Field punched/drilled into LCS  |           |           |           |
| Electrical Terminations             | 12-16ga   |           |           |           |
| Environmental Rating                | NEMA 4/4X   |           |           |           |
| Manual Override                     | 7.6" Handwheel  |           |           |           |
| Control                             | Proportional  |           |           |           |
| Actuator Case material              | Aluminum Alloy, Powder coated   |           |           |           |
| Motor Protection                    | 230°F/110°C Thermal F* Class<br>*Totally Enclosed Non-Ventilated Motors |           |           |           |
| Ambient Temperature Operating Range | -22°F to +104°F<br>-30°C to +40°C                                       |           |           |           |

## Introduction

This document provides necessary information for set-up, calibration, testing and use of the Spring Return Series of quarter-turn spring return electric actuators stated on the cover page. Each unit is shipped from the factory with initial calibration of mechanical stops, cams and switches completed for 0-90 degree operation. However, these are general settings and serve as a starting point for proper calibration of the actuator in its real-world application.

## Safety

Safety is a basic factor any time you maintain and operate mechanical equipment. Appropriate handling methods and proper use of tools and clothes can help prevent serious accidents -- accidents which can cause injuries to you or a fellow worker. This manual was created to enable a trained user to install, adjust and troubleshoot your ProMation actuator.

Only competent and trained personnel should install, maintain and operate ProMation actuators. Any work related to this actuator must be carried out in accordance with this manual and related codes and regulations. Local workplace health and safety rules should always be followed.

## Duty cycle

Duty cycle is the percent of time that an actuator spends running as a fraction of the total time. Duty Cycle is directly related to heat; excessively repositioning an actuator typically results in motor overheating which can cause permanent damage and/or reduced service life.

Duty cycle can be calculated as follows:

(example PA series actuator running 7 seconds ON and 70 seconds OFF)

Runtime = 7s, Total time = 7s + 70s = 77s, therefore this duty cycle would be 9% (7/77)

Additionally, ProMation PA~D series actuators are designed for a maximum of 300 starts per hour (one start every 12 seconds maximum).

## Shipping and Handling

1. The actuator is shipped from the factory in its Spring CW position (UNLOADED) position. Before mounting the actuator, make sure the MANUAL HANDWHEEL is able to free-wheel, indicating that the actuator is UNLOADED.
2. **NOTE: This actuator is shipped with TEMPORARY PLUGS installed in BOTH EMT ports. These temporary plugs MUST be replaced with proper fittings appropriate for use in the environment to which the actuator is to be installed. Utilize DRIP LOOPS in the conduit connections to prevent condensate from entering the actuator. Power MUST be supplied to the unit immediately upon installation to keep the anti-condensate heater warm.**
3. **Storage:** This unit should NOT be stored outside unless it is powered up and has proper conduit terminations. When this unit is NOT powered up, it should be stored in a clean, dry environment at all times.
4. This actuator has been **factory calibrated to operate between 0 degrees and 90 degrees. Most quarter-turn products will not require recalibration of these settings.** If any travel adjustment is necessary, please refer to pages 6-8 for instructions.



Bottom view of actuator showing the 8 point drive shaft and the ISO 5211 mounting hole pattern.

## Product Mounting and Setup

1. Fully CLOSE the valve or damper to which the actuator is to be mounted.
  - Keep in mind this spring CW actuator rotates CW (as viewed from above the unit) when the unit springs closed (UNLOADED).
2. Assemble necessary linkage components and attach the actuator to the driven device.
3. Tighten mounting bolts, making sure actuator is centered on the device drive shaft.
4. Utilize the handwheel to check for unobstructed manual operation from fully CCW to fully CW positions BEFORE applying power to the unit.
5. Make the electrical connections per wiring diagram on page 4.
  - Connect POWER to terminals marked 2 and 6 on the transformer.
  - Connect CONTROL to terminals marked 6, 7, 11, and 12 on the terminal block.
  - Actuator accepts a 4-20mA (default), 0-10VDC, 1-5VDC, or 2-10VDC CONTROL Signal.
  - Terminals labelled A-F are for the (adjustable) aux switches. They are dry type Form C rated 10A @ 250vac MAX.
  - Terminals A-C are for the open position (adjustable).
  - Terminals D-F are for the closed position (adjustable).
6. Do NOT apply power at this time.

## Installation Notes

- These actuators are designed to be used between a horizontal and upright position. Do NOT mount the assembly with the actuator top below a horizontal position.
- When installing conduit, use proper techniques for entry into the actuator. Use drip loops to prevent conduit condensate from entering the actuator.
- The mechanical travel stop is factory calibrated for the Spring CW (UNLOADED) position. The stop is NOT designed to adjust the Spring CW (UNLOADED) position by more than +/- 3 degrees.
- There is no mechanical stop for the LOADED position. Use caution when using the handwheel and make sure you do NOT rotate the actuator beyond the LOADED position. Observe the position by using the visual position indicator.
- Both NPT conduit ports MUST use proper equipment to protect the NEMA 4X integrity of the housing.
- The internal heater is to be used in ALL applications.
- Do NOT install the actuator outdoors or in humid environments unless it is powered up and the heater is functioning.
- Use proper wire size to prevent actuator failure (see chart on page 4 for proper wire sizing).
- All terminals accept 12-16AWG solid/stranded wire.

# Wiring Diagram

## Proportional Control

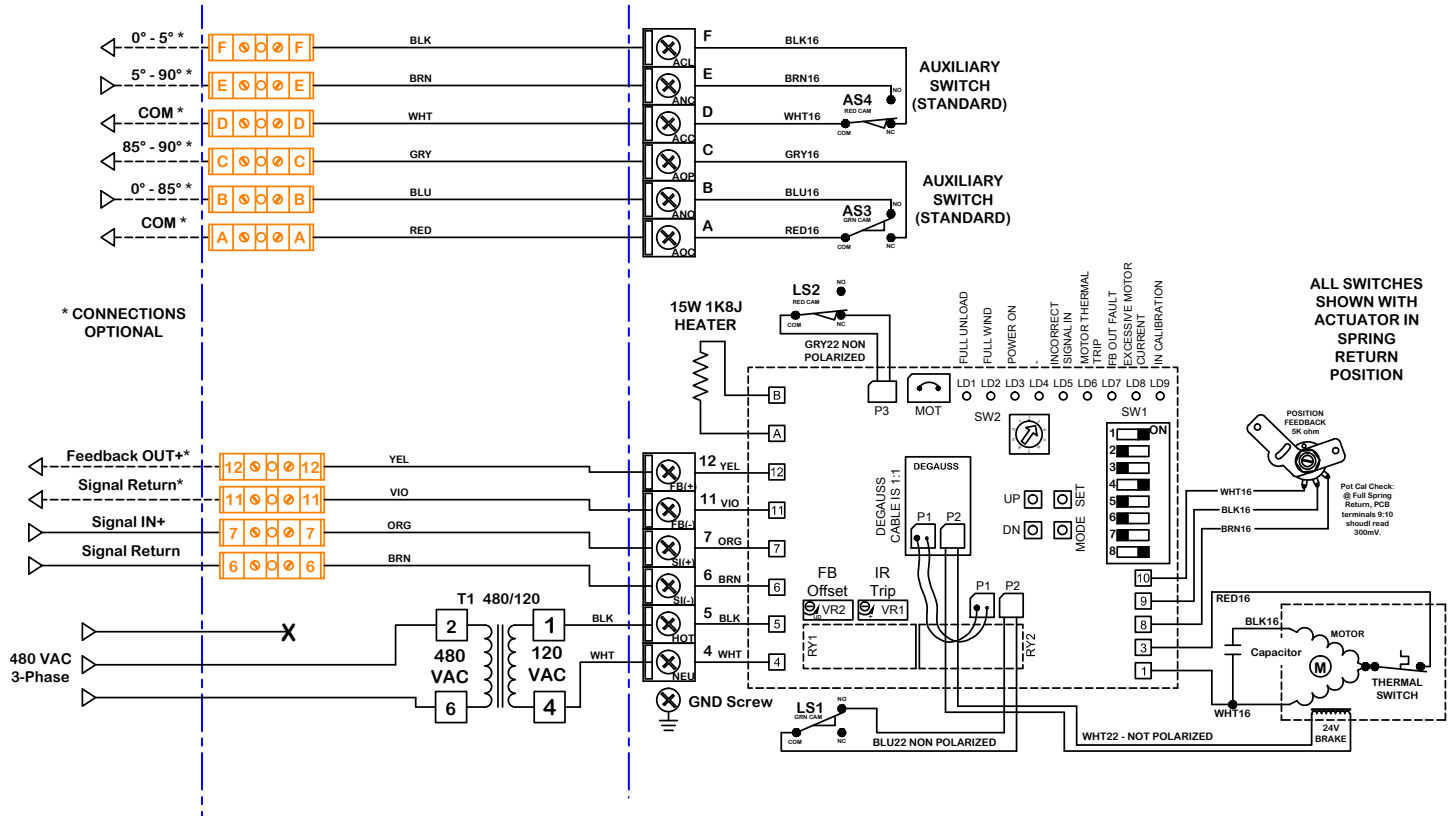

### Field Wiring

### Local Control Station Wiring

### Internal Actuator Wiring

480/3φ Wiring Diagram Shown

## Wire Sizing Chart

Wire sizing data is provided in the table to assist in the selection of the proper wire size for ProMotion actuators using various wire sizes over distance.

Please make sure to reference the correct voltage and do not exceed the indicated length of the wire run for each model.

| MAX distance between Actuator and Supply (feet) |                  |                  |                  |                  |
|---|------------------|------------------|------------------|------------------|
| Actuator/<br>Voltage                            | PAO<br>230VAC 3φ | PAO<br>380VAC 3φ | PAO<br>440VAC 3φ | PAO<br>480VAC 3φ |
| Amps  | 1.04A            | 0.63A            | 0.55A            | 0.50A            |
| Wire Gage                                       |                  |                  |                  |                  |
| 16  | 2289             | 3779             | 8658             | 10390            |
| 14  | 3698             | 6105             | 13986            | 16783            |
| 12  | 5656             | 9337             | 21390            | 25668            |
| 10  | 9615             | 15873            | 36364            | 43636            |
| 8   | 14351            | 23691            | 54274            | 65129            |

# Layout of controller

## Proportional Control

### With the power OFF

1. Set the 8 position DIP switch for proper operation. Refer to the table for settings.



### Input, Feedback, Direct Acting, and Loss of Signal Table

| DIP Switch Setting | DIP Switch Setting | DIP Switch Setting | Functions                             |
|--------------------|--------------------|--------------------|---------------------------------------|
| DIP 1 On           | DIP 2 Off          |                    | 4-20mA Signal Input                   |
| DIP 1 Off          | DIP 2 Off          |                    | 1-5V Signal Input                     |
| DIP 1 Off          | DIP 2 On           |                    | 2-10V Signal Input                    |
| DIP 3 Off          | DIP 4 On           | Dip 5 Off          | 4-20mA Signal Output                  |
| DIP 3 On           | DIP 4 Off          | Dip 5 On           | 2-10V Signal Output                   |
| DIP 6 Off          |                    |                    | Direct Acting Mode                    |
|                    | DIP 7 On           | DIP 8 On           | Stay in Place on LOSS of Input Signal |
|                    | DIP 7 Off          | DIP 8 On           | CW on LOSS of Input Signal (Spring)   |
|                    | DIP 7 On           | DIP 8 Off          | CCW on LOSS of Input Signal (Wind)    |
| DIP 6 On           |                    |                    | Reverse Acting Mode                   |
|                    | DIP 7 On           | DIP 8 On           | Stay in Place on LOSS of Input Signal |
|                    | DIP 7 Off          | DIP 8 On           | CCW on LOSS of Input Signal (Wind)    |
|                    | DIP 7 On           | DIP 8 Off          | CW on LOSS of Input Signal (Spring)   |

### Default Settings

### Product Mounting and Setup

2. This section assumes the actuator is mounted to the valve or damper. Remember, the actuator is shipped in the spring return (UNLOADED) position. When viewed from ABOVE the actuator, the spring CW units spring closed (UNLOADED) in a CW direction. Make sure your valve or damper are in the CORRECT fail position before proceeding.
3. [Apply power to the actuator](#) and generate a control signal to drive the actuator to the CCW (LOADED) position. Then remove power to allow the spring return system to drive the device back to the fail position -- CW (UNLOADED).

**For units with override handwheel: make sure the override handwheel is completely free from any mechanical load before proceeding to Adjusting the actuator End-Stop Position.**

## Adjusting Mechanical End-Stop Position CW Position (UNLOADED)

This actuator has been factory calibrated to operate between 0 degrees and 90 degrees. Most quarter-turn products will not require recalibration of these settings. The following procedure is a reference for set-up, calibration, testing and use of the Spring Return quarter-turn electric actuators.

**Warning: Make NO adjustments to this device until you have contacted the factory (352-544-8436) for assistance. Damage to product as a result of incorrect cam and/or mechanical adjustments will NOT be covered under warranty!**



Remove adjustment housing cover.  
Refer to step 4

### Remove Adjustment Housing Cover

4. If it is determined that the CW (UNLOADED) end-stop position is not correctly aligned, it will be necessary to ADJUST the mechanical END STOP. To do this, remove the adjustment housing cover using a 5mm hex key.



Loosen lock nut.  
Refer to step 5

### Loosen Lock Nut and Adjust End Stop

5. There will be an adjustment nut and a lock nut inside the housing. Loosen the lock nut using a 22mm hex wrench, and while holding the nut, use a 10mm open end wrench to turn the adjustment nut. (CW to move the end stop more towards the LOADED direction, or CCW to move the end stop further AWAY from the LOADED direction). Do NOT turn the adjustment nut more than 5 turns in either direction!



Turn the adjustment nut to adjust  
UNLOADED position.  
Refer to step 5

### Tighten Lock Nut and Reattach Adjustment Housing Cover

6. Tighten the 22mm locknut to secure the adjustment.
7. Reattach the cover removed in step 4.



## Adjusting Cam Position for CW Position (UNLOADED)

**Do NOT rotate the cams more than 3 degrees... Serious Damage to the actuator will result if the motor or handwheel is allowed to drive the gear train beyond the recommended spring compression!**

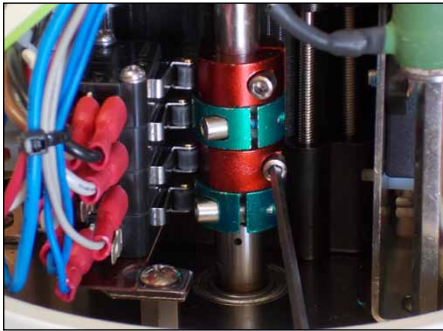

Refer to steps 8-10

### Adjust Cam 2

- It will now be necessary to re-adjust the electrical travel cam to coincide with the new mechanical stop adjustment made in the steps above. With NO POWER APPLIED to the actuator, use a 2.5mm hex key to loosen the #2 (RED) cam set screw. Once it is free, rotate the hex key to the RIGHT a few degrees to reset the switch roller arm. Then snug the set screw up against the camshaft (CW) until slight pressure is felt. Then SLOWLY rotate the hex key pushing the cam to the LEFT until you hear the “click” on the second switch indicating that correct adjustment has been achieved. Tighten the cam set screw.

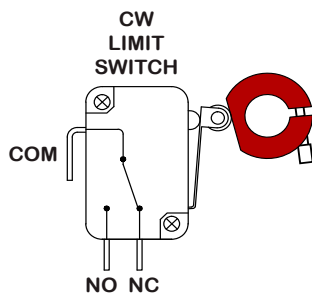

Note that this setting is only for “proof” that the unit has reached the full spring return position. **Adjusting this cam does not affect the spring return travel of the actuator.**

- NOTE: Incorrectly adjusted cams will prevent the actuator from running under power.**
- Apply power and generate a control signal to drive the actuator approximately 20 degrees CCW. Remove power to let the spring return system drive back to the new end adjustment. Check the setting and repeat from step 3 if necessary.

## Adjusting Cam Position for CCW Position (LOADED)

**DO NOT attempt to adjust the CCW end of travel unless it is absolutely necessary.**

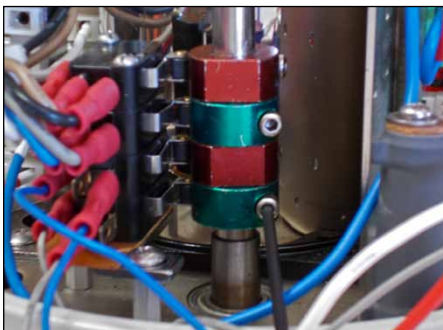

Refer to steps 11-12

- Again apply power and generate a control signal to drive the actuator to the LOADED position. The actuator will stop and HOLD when it reaches it's end of travel.

**DO NOT attempt to adjust the CCW end of travel unless it is absolutely necessary.** This can ONLY be done with power applied. If you remove power, the actuator will spring closed, making it impossible to make the adjustment. If you move the cam too far to the LEFT, the motor will drive the geartrain beyond the full compression of the springs. ***This will DAMAGE the spring system. USE EXTREME CAUTION IF ADJUSTMENT IS NEEDED.***

### Adjust Cam 1

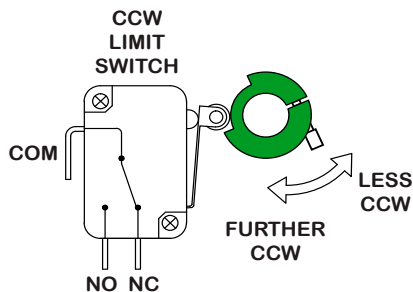

- If the STOP point is incorrect, the #1 (GREEN) cam must be adjusted. Use a 2.5mm hex key to loosen the cam set screw. SLOWLY rotate the hex key pushing the cam to the LEFT to drive FURTHER CCW, or to the RIGHT to drive LESS CCW.

- Tighten the cam set screw.

## Set Proportional Card Limits

**Warning: Make NO adjustments to this device until you have contacted the factory (352-544-8436) for assistance. Damage to product as a result of incorrect cam and/or mechanical adjustments will NOT be covered under warranty!**



14. Set the new control limits of the programmable card (required ONLY if changes are made to the mechanical travel stops as detailed in steps 5-13:

- a. Press and hold “SET” for 2 seconds, then LD9 comes on, indicating MANUAL mode.
- b. Press and hold “UP” to drive the actuator to LOADED position.
- c. Generate the desired control signal for the LOADED position (i.e. 20mA for direct acting).
- d. Press “MODE” once. The LOADED position is now set.
- e. Press and hold “DN” to drive the actuator to UNLOADED position.
- f. Generate the desired control signal for the UNLOADED position (i.e. 4mA for direct acting).
- g. Press “MODE” once. The UNLOADED position is now set.
- h. Press “SET” once to finalize the above settings.

### LED Indicators

|                           |                              |
|---------------------------|------------------------------|
| LD1 = Spring Full Un-Wind | LD5 = Incorrect Input Signal |
| LD2 = Spring Full Wind    | LD6 = Motor Thermal Overload |
| LD3 = Power               | LD7 = Feedback Signal short  |
| LD4 = n/a                 | LD8 = Motor Current Overload |
|                           | LD9 = Manual Mode            |

### Note:

LD1 will be lit while moving in the unwind direction.  
LD2 will be lit while moving in the wind direction

## Adjusting the actuator Auxiliary Switches

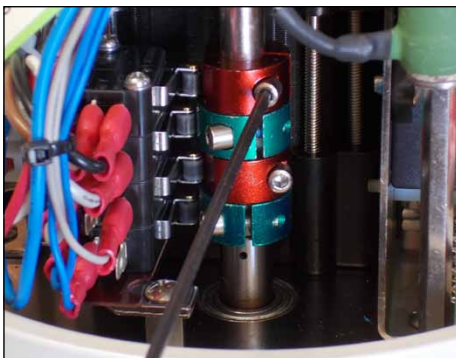

Cam 4

### Adjust Cam 4

1. The fourth (RED) cam is the CW auxiliary switch adjustment. Spring return the actuator to its CW position. Then use a 2.5mm hex key to free up the cam set screw. Once it is free, rotate the hex key to the RIGHT a few degrees to reset the switch roller arm. Then snug the set screw up against the camshaft until slight pressure is felt. Then SLOWLY rotate the hex key and cam to the LEFT until you hear the “click” on the fourth switch. Continue to rotate the cam between 3 and 5 degrees to the LEFT to make sure the auxiliary cam switch changes state before the actuator reaches its end of travel electrically. Tighten the cam set screw.

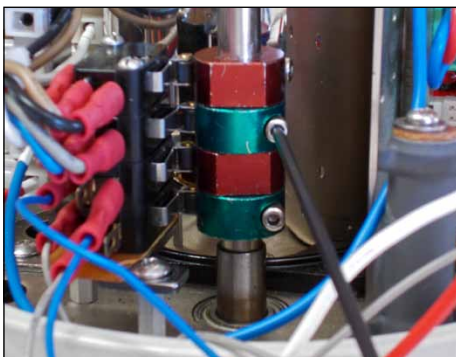

Cam 3

### Adjust Cam 3

1. The THIRD (GREEN) cam is the CCW auxiliary switch adjustment. Drive the actuator to its CCW position. Then use a 2.5mm hex key to free up the cam set screw. Once it is free, rotate the hex key to the LEFT a few degrees to reset the switch roller arm. Then snug the set screw up against the camshaft until slight pressure is felt. Then SLOWLY rotate the hex key and cam to the RIGHT until you hear the “click” on the third switch. Continue to rotate the cam between 3 and 5 degrees to the RIGHT to make sure the auxiliary cam switch changes state before the actuator reaches its end of travel electrically. Tighten the cam set screw.

# Mechanical Data

# PAO CW Series Dimensional Data

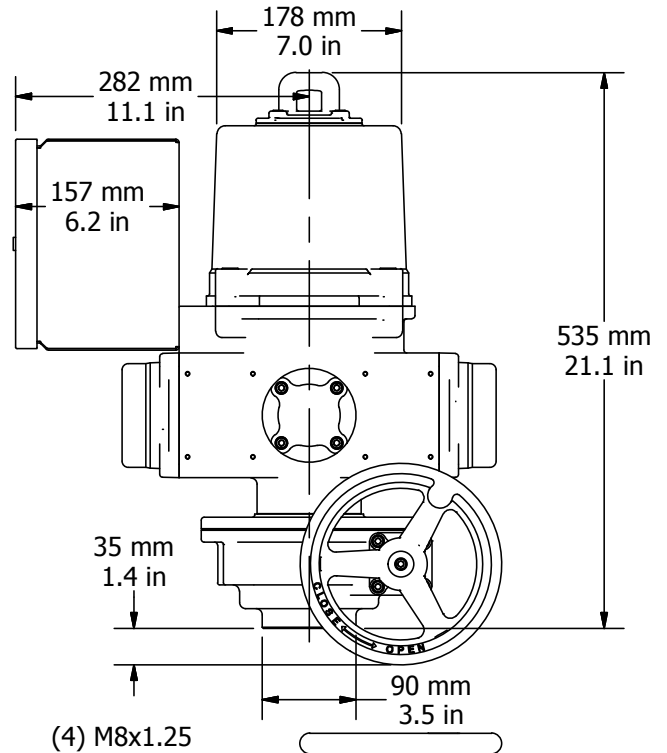
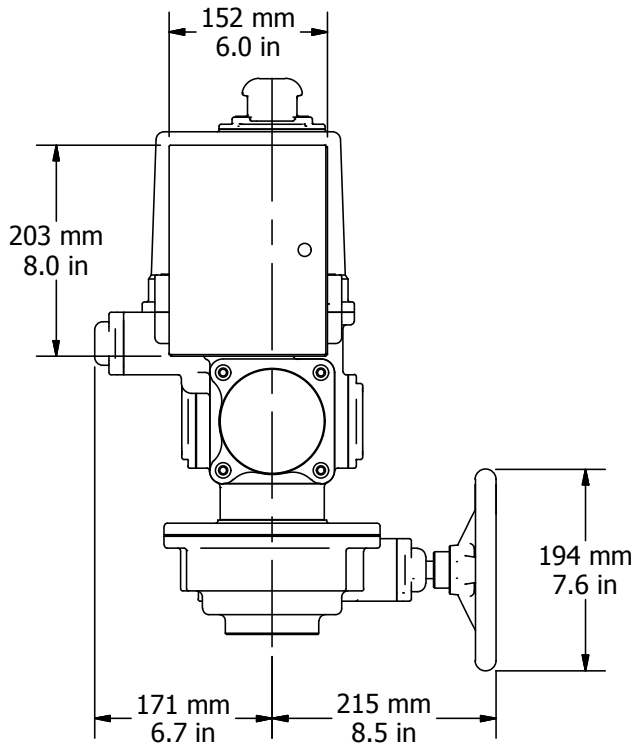
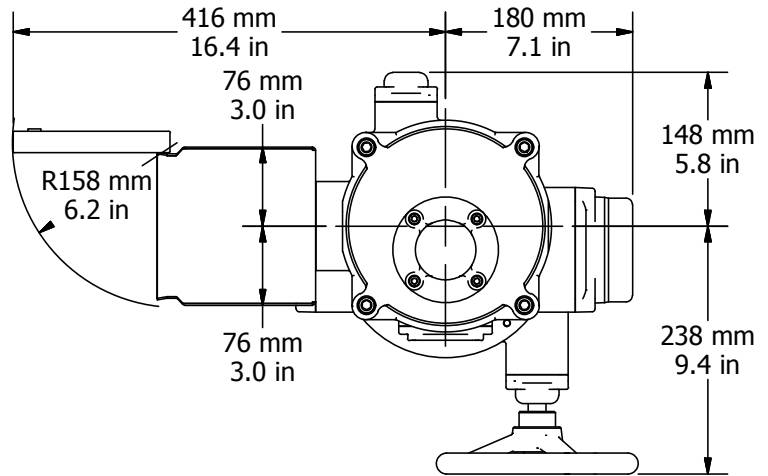
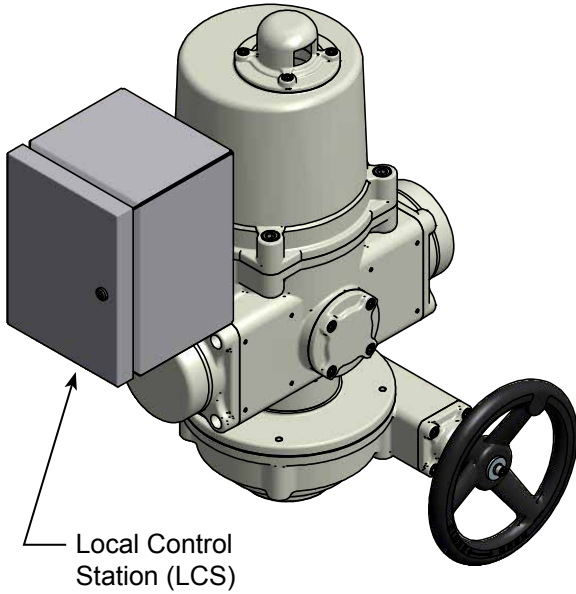

### Drive Coupling Fabrication Data

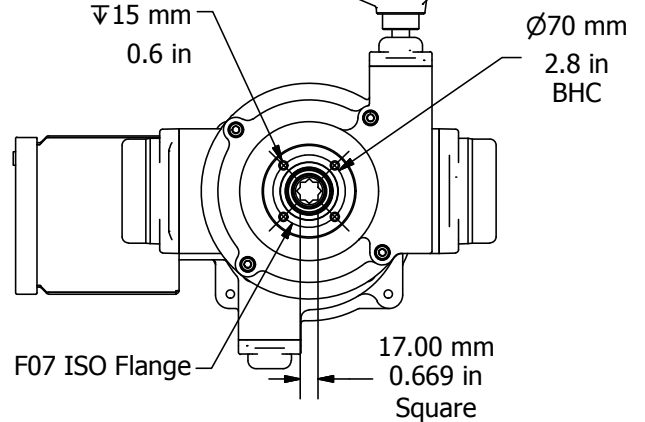
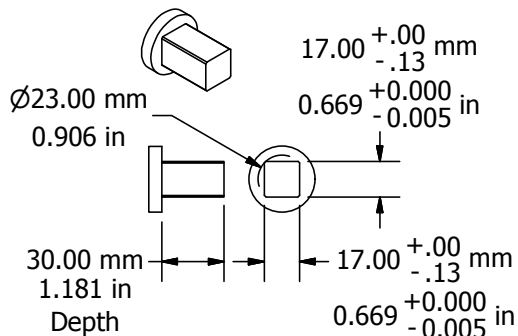

FM15\_PAOW CW 3ph PS4 Ver G 072015

# Mechanical Data

## Spring Return Series Exploded View

(PAO-CW-1202S4 unit is shown)

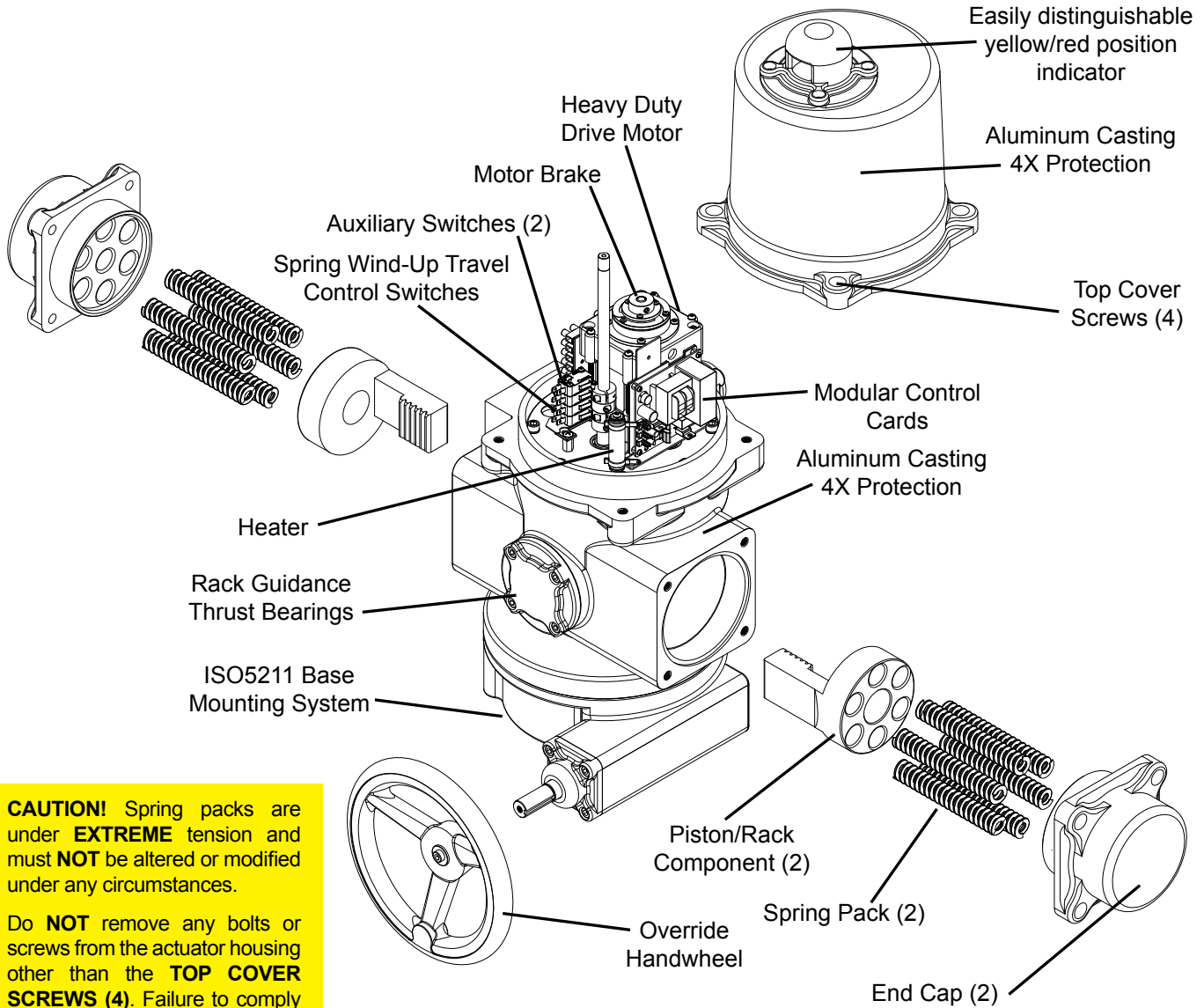

**CAUTION!** Spring packs are under **EXTREME** tension and must **NOT** be altered or modified under any circumstances.

Do **NOT** remove any bolts or screws from the actuator housing other than the **TOP COVER SCREWS (4)**. Failure to comply with this warning could cause **severe bodily injury**.

## Switch Logic Map and Switch/Cam Arrangement

Switch sequencing data is provided in the table to show the change-of-state points during the rotation of the actuator from CCW to CW and back again. The red bar shows when that terminal makes with its respective common.

Switches 1 and 2 are set at the factory and should NOT be changed. The INCLUDED auxiliary switches SW3 & SW4 are for terminals A thru F and those set points may be modified if need be.

| Terminal ID# | CW                 |    |    | CCW |     |     |
|--------------|--------------------|----|----|-----|-----|-----|
|              | -5°                | 0° | 5° | 85° | 90° | 95° |
| F            | Fully UNLOADED     |    |    |     |     |     |
| E            | Not Fully UNLOADED |    |    |     |     |     |
| D            | UNLOADED Common    |    |    |     |     |     |
| C            | Fully LOADED       |    |    |     |     |     |
| B            | Not Fully LOADED   |    |    |     |     |     |
| A            | LOADED Common      |    |    |     |     |     |

SW4 CW AUX  
(Factory Set - Adj)

SW3 CCW AUX  
(Factory Set - Adj)

Used by Controller

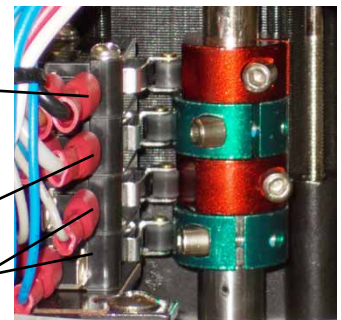

FM15\_PAO CW 3ph PS4 Ver G 072015

## **Commissioning**

**After completing all mounting and wiring procedures and main power is available, it is now possible to commission the actuator.**

1. For units with a handwheel, utilize the handwheel to rotate the actuator and damper, valve or other connected device through its full travel from UNLOADED to LOADED and back again to check for any possible interference.  
Do NOT utilize any mechanical advantage devices to rotate the handwheel (pipes, wrenches, extension bars, etc.). The spring will drive the device CW, following the rotation of the handwheel.
2. Apply correct power to the unit.
3. Measure 120vac power on terminals 5 (Hot / L1) & 4 (Neu / L2) on the switch board.
4. Command the field device to generate a signal to drive the actuator towards the LOADED position.  
The actuator rotates in a CCW direction (as viewed from above).
5. Actuator will stop when it reaches it's LOADED position.
6. Command the field device to generate a signal to drive the actuator towards the UNLOADED position.  
The actuator spring returns in a CW direction (as viewed from above).
7. Actuator will stop when it reaches it's UNLOADED position and the handwheel (if equipped) is not blocking the full spring return positioning.
8. Actuator is now commissioned and operational.

# Troubleshooting

## Spring Return Actuator UNLOADED position and not restarting on power-up

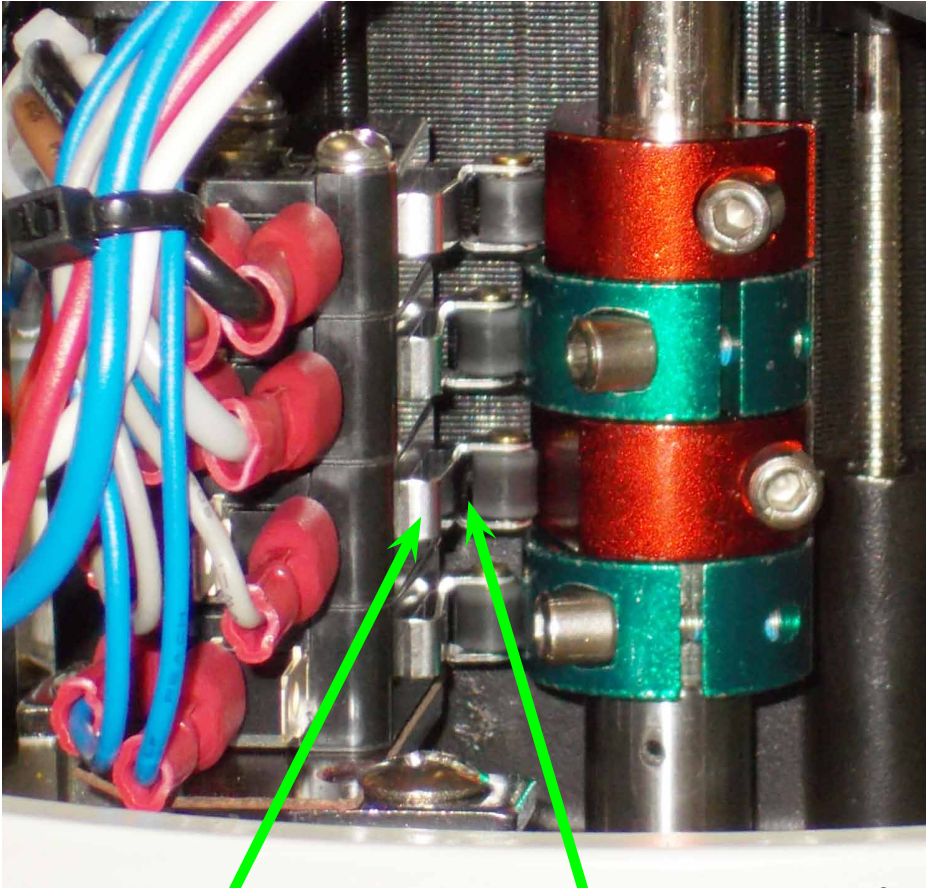

### #2 Cam switch lever.

Press towards black switch body to hear "click". The switch will also click as it releases.

### #2 Cam switch.

At actuator UNLOADED position you should be able to depress the #2 switch LEVER and hear it "click".

If no "click" is heard and the actuator is in fact UNLOADED, the cam is in the wrong position and is keeping the switch from changing state. Use a 2.5mm hex key and rotate the RED #2 cam SLIGHTLY CW until "click" is heard. Lightly resecure the cam in position to test. Secure fully after testing.

## #2 Cam Positions: UNLOADED

Incorrect

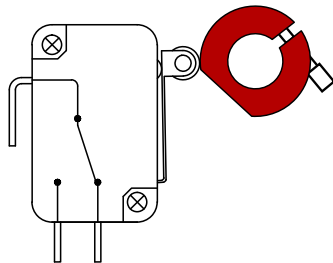

Lower RED cam position showing the switch roller riding high on the cam lobe. In this position, you cannot press on the switch roller lever and hear the switch "click". In this position, the actuator will NOT restart after a power failure.

Correct

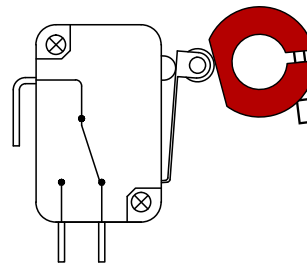

Lower RED cam position showing the switch roller sitting in the CORRECT position at the full spring return end of travel.

With the switch roller positioned as shown, the switch will "click" when the switch roller lever is pressed and the controller WILL restart after a power failure.

# Spring Return Manual Override Orientation -CW

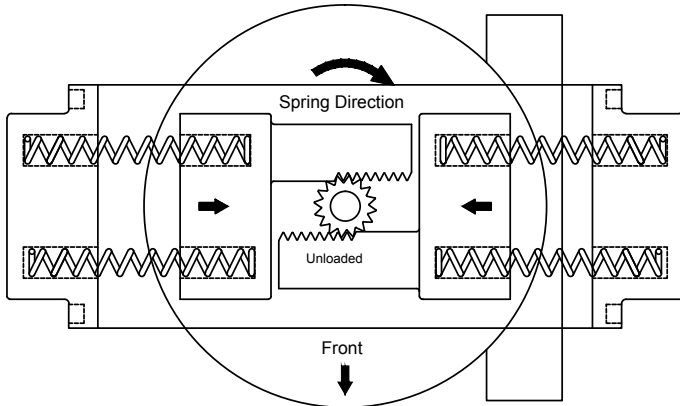

Actuator viewed from ABOVE

Default Configuration is Spring CW (from above).  
Left side rack is in back, Right side rack is in front.

Diagrams describing the inner mechanical actions of a typical spring return actuator with manual override (OVD) system.

Graphic depicts the interaction of the unloading spring action to the racks which translate to rotation in the direction shown.

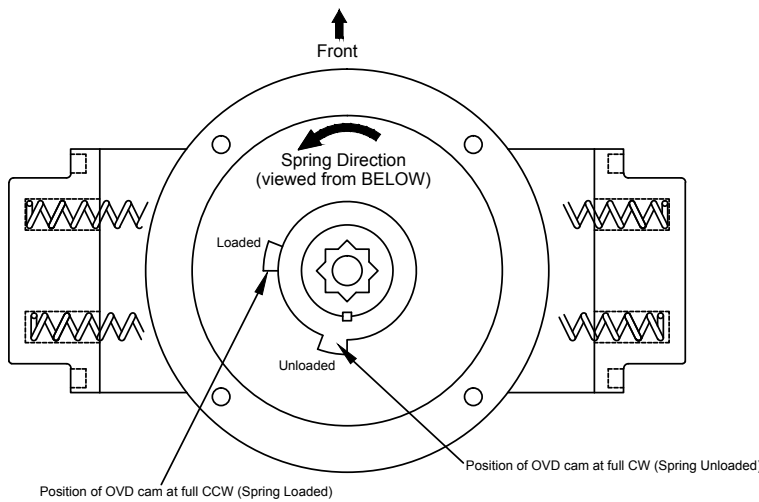

Actuator viewed from BELOW with OVD system removed

Graphic depicts the rotation of the output drive portion of the actuator as seen from below.

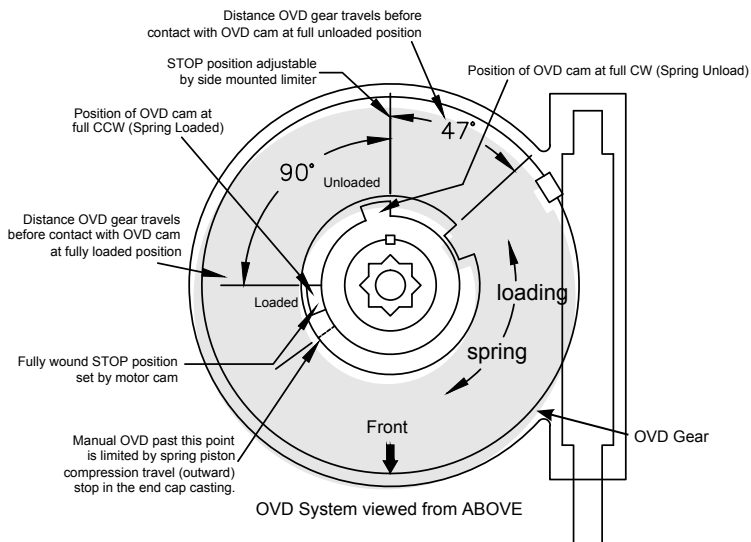

OVD System viewed from ABOVE

Graphic depicts the rotation of the override mechanism (OVD) as it relates to the output drive from above.

It shows the amount of rotational travel the OVD Gear makes (47°) before contacting the OVD cam (freewheeling) and the amount of rotational travel it makes (an additional 90°) while compressing the springs on the way to it's LOADED position.

FM15\_PA0 CW 3ph PS4 Ver G 072015

# Industrial Applications

ProMation Engineering actuators have been installed to operate process controls such as butterfly valves, ball valves, high performance valves, plug valves, gate valves and dampers, in a broad range of demanding industrial applications.

**Power  
Generation**



**Water  
Processes**



**Mining**



**Oil and Gas**



**Agriculture**

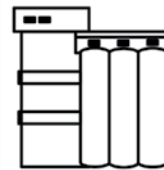

**Chemicals**



## Complete Support

ProMation Engineering is committed to providing superior customer support for your sales, project management and installation teams. Contact us today.

### Full Documentation

We offer complete wiring diagrams, field installation manuals and set up documentation for all our products, both in printed and digital form. We regularly host customized educational webinars for our customers.

### RapidQuote

Most quotes and estimates are generated within hours of the request.

### ProMation Engineering Services

ProMation Engineering can provide design and technical services for OEM's, projects with customized requirements and specialized operations.

ProMation Engineering follows a policy of continual product updates and enhancements. Our website is the best place to obtain the latest product documentation, including the wiring diagrams for these controllers. Visit us at [www.promationei.com](http://www.promationei.com) or use the code to link to the site.



**PROMATION  
ENGINEERING**

*Precision Actuation for Industry*

16138 Flight Path Drive  
Brooksville, FL 34604

Phone (352) 544-8436 Fax (352) 544-8439  
email: [sales@promationei.com](mailto:sales@promationei.com)



Use your smart phone barcode scanner app here.