

**PROMATION
ENGINEERING**

Precision Actuation for Industry

Installation & Operation Manual

**This IOM is for the following
ProMation Engineering Products:**

LCS LA-01-120

LCS LA-01-230

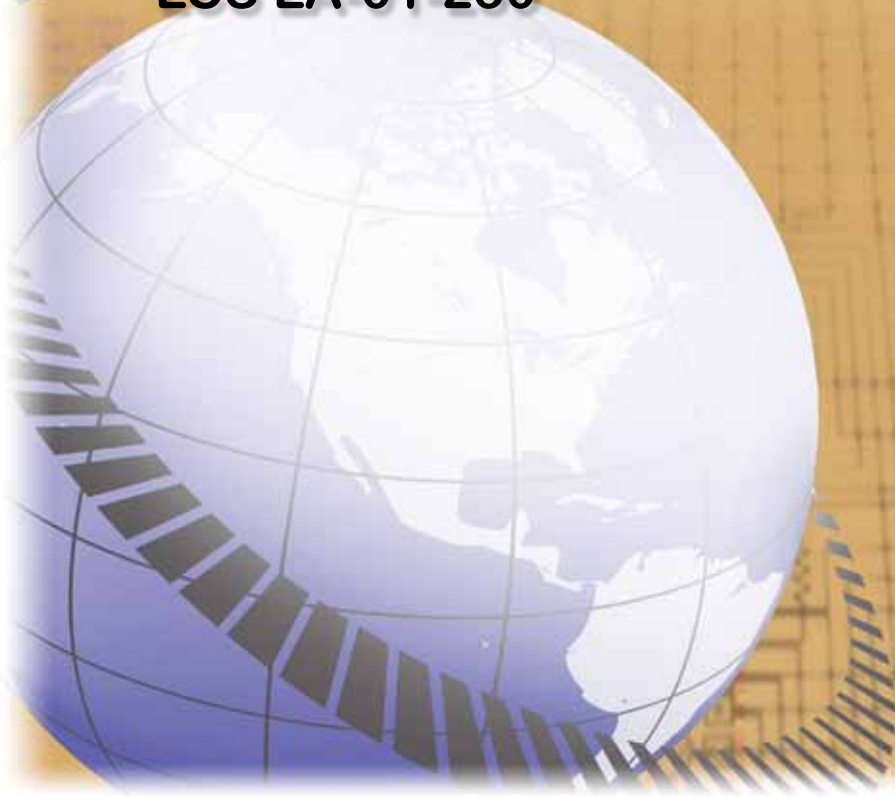



**PROMATION
ENGINEERING**

Precision Actuation for Industry

Field Manual LCS LA-P1-HV

Local Control Station
On/Off/Jog Control



FM_LCS_LA-LD-P1-HV_Ver A.052020

Contents

2	Product Specifications:
3	Product Handling and Installation
3	Wiring Diagram
4	Component Identification
5	LCS Feature Selection Chart
5	Component Identification
5	Mechanical Data

Product Specifications:

	Local Control Station: LA-01-HV
Torque "lb/Nm	Actuator dependent
For Actuator Series	P1, P1.A
Supply Voltage	120vac, 230vac
Max Inrush Current	N/A
Running Current	N/A
Runtime (90°@60/50Hz)	Actuator dependent
Weight	7lbs/3kg (case and components)
Mechanical Connections	Actuator Dependent
Electrical Entry to box	Field punched/drilled into enclosure for mounting
Electrical Terminations	Altech terminal blocks that accept 12-16ga wire.
Environmental Rating	NEMA 4 (Local Control Station Enclosure)
Override	Local/Off/Remote Switch
Control	On/Off/Jog
Duty Cycle	Actuator Dependent
Controller Case material	Steel
Ambient Temperature Operating Range	-22°F to +150°F -30°C to +65°C

Introduction

This document provides necessary information for set-up, calibration, testing and use of the L Series Local Control Stations for quarter-turn electric actuators. Each unit is shipped from the factory with wiring completed as shown in the Wiring Diagram and ready to be installed.

Safety

Safety is a basic factor any time you maintain and operate mechanical equipment. Appropriate handling methods and proper use of tools and clothes can help prevent serious accidents -- accidents which can cause injuries to you or a fellow worker. This manual was created to enable a trained user to install, adjust and troubleshoot your ProMation actuator.

Only competent and trained personnel should install, maintain and operate ProMation Local Control Stations and actuators. Any work related to this actuator must be carried out in accordance with this manual and related codes and regulations. Local workplace health and safety rules should always be followed.

Product Handling and Installation

1. Storage: This unit should NOT be stored outside unless it is powered up and has proper conduit terminations. When NOT powered up, it should be stored in a clean, dry environment at all times.
2. **Note: this enclosure must have water tight EMT fittings, with conduit drainage installed to keep it dry at the time of installation.**
3. **The switches located on the front of the enclosure do NOT function as service disconnects.**
4. Do NOT wire multiple actuators to or from the Local Control Station.

Wiring Diagram

On/Off/Jog Control

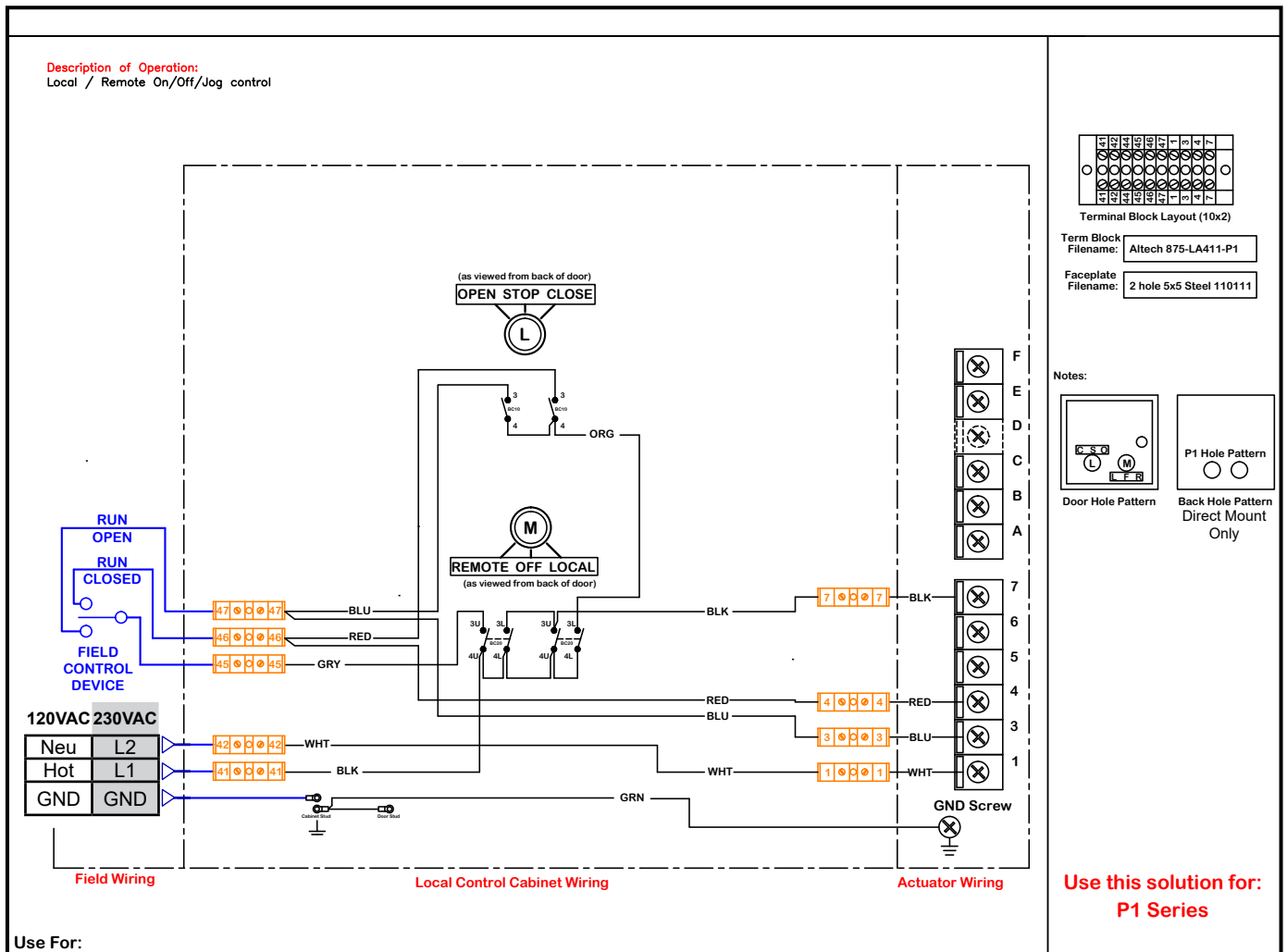

FM_LCS_LA-LD-P1-HV_Ver A 052020

Component Identification

Controls - Front Panel

FM_LCS_LA-LD-P1-HV_Ver A 052020



Latch

Quarter-turn, screwdriver access. Opens cabinet door to gain access to wiring terminal blocks and actuator wiring entry.

Close / Stop / Open Switch

This knob switch selects the run direction in which the actuator operates. In the CLOSE position, the actuator will drive closed. In the STOP position, the actuator stops driving. In the OPEN position, the actuator will drive open.

Local / Off / Remote Mode Switch

This knob switch selects the control mode in which the actuator operates. In the LOCAL position, the actuator is commanded by the Close / Stop / Open Switch. In the OFF position, the actuator accepts no commands. In the REMOTE position, the actuator is commanded by the field control device, (typically a central control point).

FM_LCS_LA-LD-P1-HV_Ver A 052020

WARNING!

The Mode switch does NOT function as a service disconnect!
Power is still present inside this enclosure when the mode switch is OFF.

Component Identification

Product Controls



LCS Model	LA	LB	LC	LD	LE	LF	LG	LH	LI	LJ	LK
Product	All	All	All	All	All	P1,PA,PL	P2-13	P1,PA,PL	P2-13	P1,PA,PL	P2-13
For On/Off/Jog Actuators Only	X	X	X	X							
For Proportional Actuators Only					X	X	X	X	X	X	X
Local/Off/Remote Mode Switch	X	X	X	X	X	X	X	X	X	X	X
Close-Stop-Open Switch	X	X	X	X							
Close-Open Switch (2 Pos)					X	X	X				
Close / Open Indicator Lights		X	X	X		X	X	X	X	X	X
End of Travel (EOT) Outputs to Controller		X	X	X		X	X	X	X	X	X
Mode Switch Position Signal to Controller			X	X		X	X	X	X	X	X
Illuminated Power Indicator				X		X	X				
Full Proportional Control via Potentiometer								X	X	X	X
LCD Display for Incoming Signal								X	X	X	X
LCD Display for Feedback Signal										X	X

Mechanical Data

Product Controls

SAMPLE DIAGRAM

LCS and actuator are shown is only a sample and may not represent all components completely. The dimensions are correct for the LCS

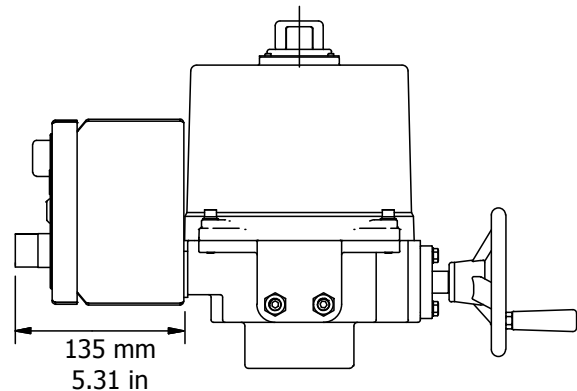
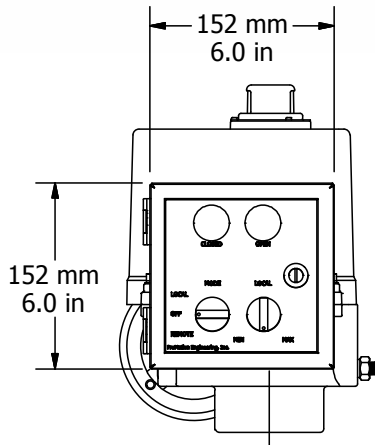
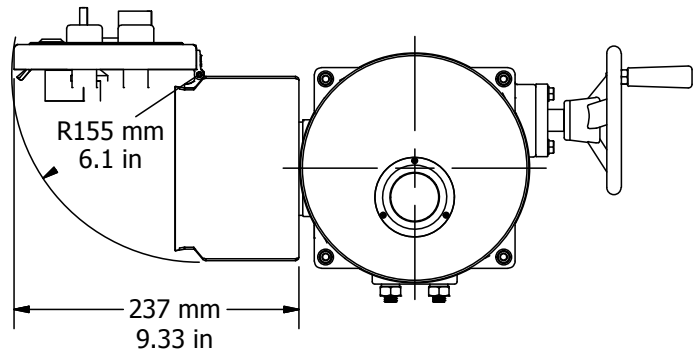
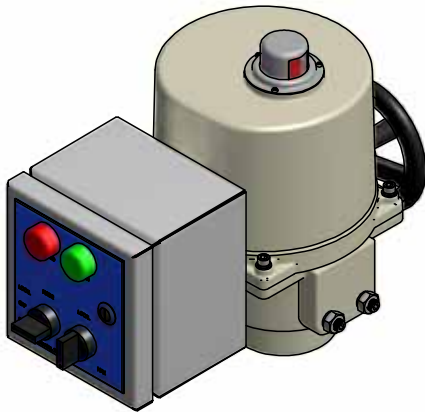

FM_LCS_LA-LD-P1-HV_Ver A.052020

Industrial Applications

ProMation Engineering actuators have been installed to operate process controls such as butterfly valves, ball valves, high performance valves, plug valves, gate valves and dampers, in a broad range of demanding industrial applications.

**Power
Generation**



**Water
Processes**



Mining



Oil and Gas



Agriculture



Chemicals



Complete Support

ProMation Engineering is committed to providing superior customer support for your sales, project management and installation teams. Contact us today.

Full Documentation

We offer complete wiring diagrams, field installation manuals and set up documentation for all our products, both in printed and digital form. We regularly host customized educational webinars for our customers.

RapidQuote

Most quotes and estimates are generated within hours of the request.

ProMation Engineering Services

ProMation Engineering can provide design and technical services for OEM's, projects with customized requirements and specialized operations.

ProMation Engineering follows a policy of continual product updates and enhancements. Our website is the best place to obtain the latest product documentation, including the wiring diagrams for these controllers. Visit us at www.promationei.com or use the code to link to the site.



**PROMATION
ENGINEERING**

Precision Actuation for Industry

16136 Flight Path Drive
Brooksville, FL 34604

Phone (352) 544-8436 Fax (352) 544-8439

email: sales@promationei.com