

**PROMATION
ENGINEERING**

Precision Actuation for Industry

Installation & Operation Manual

**This IOM is for the following
ProMation Engineering Products:**

**OPT LCS LK 213 120 R/D
OPT LCS LK 213 230 R/D**



**PROMATION
ENGINEERING**

Precision Actuation for Industry

Field Manual LCS LK-213-HV

Local Control Station
Proportional Control



FM20_LCS_LE_G1_K_Ver C 011823

Table of Contents

1	Table of Contents
2	Product Specifications:
3	Product Handling and Installation
3	Wiring Diagram
4	Component Identification
5	LCS Feature Selection Chart
5	Component Identification
5	Mechanical Data

Product Specifications:

	Local Control Station: LK
Torque "lb/Nm	Actuator dependent
Supply Voltage	120/230vac
Max Inrush Current	N/A
Running Current	N/A
Runtime (90°@60/50Hz)	Actuator dependent
Weight	7lbs/3kg (case and components)
Mechanical Connections	Actuator Dependent
Electrical Entry to box	Field punched/drilled into enclosure for mounting
Electrical Terminations	Altech terminal blocks that accept 12-16ga wire.
Environmental Rating	NEMA 4 (Local Control Station Enclosure)
Override	Local/Off/Remote Switch
Control	Proportional
Duty Cycle	Actuator Dependent
Controller Case material	Steel
Ambient Temperature Operating Range	-22°F to +150°F -30°C to +65°C

Introduction

This document provides necessary information for set-up, calibration, testing and use of the L Series Local Control Stations for quarter-turn electric actuators. Each unit is shipped from the factory with wiring completed as shown in the Wiring Diagram and ready to be installed.

Safety

Safety is a basic factor any time you maintain and operate mechanical equipment. Appropriate handling methods and proper use of tools and clothes can help prevent serious accidents -- accidents which can cause injuries to you or a fellow worker. This manual was created to enable a trained user to install, adjust and troubleshoot your ProMation actuator.

Only competent and trained personnel should install, maintain and operate ProMation Local Control Stations and actuators. Any work related to this actuator must be carried out in accordance with this manual and related codes and regulations. Local workplace health and safety rules should always be followed.

Product Handling and Installation

1. Storage: This unit should NOT be stored outside unless it is powered up and has proper conduit terminations. When NOT powered up, it should be stored in a clean, dry environment at all times.
2. **Note: this enclosure must have water tight EMT fittings, with conduit drainage installed to keep it dry at the time of installation.**
3. **The switches located on the front of the enclosure do NOT function as service disconnects.**
4. Do NOT wire multiple actuators to or from the Local Control Station.

Wiring Diagram

Proportional Control

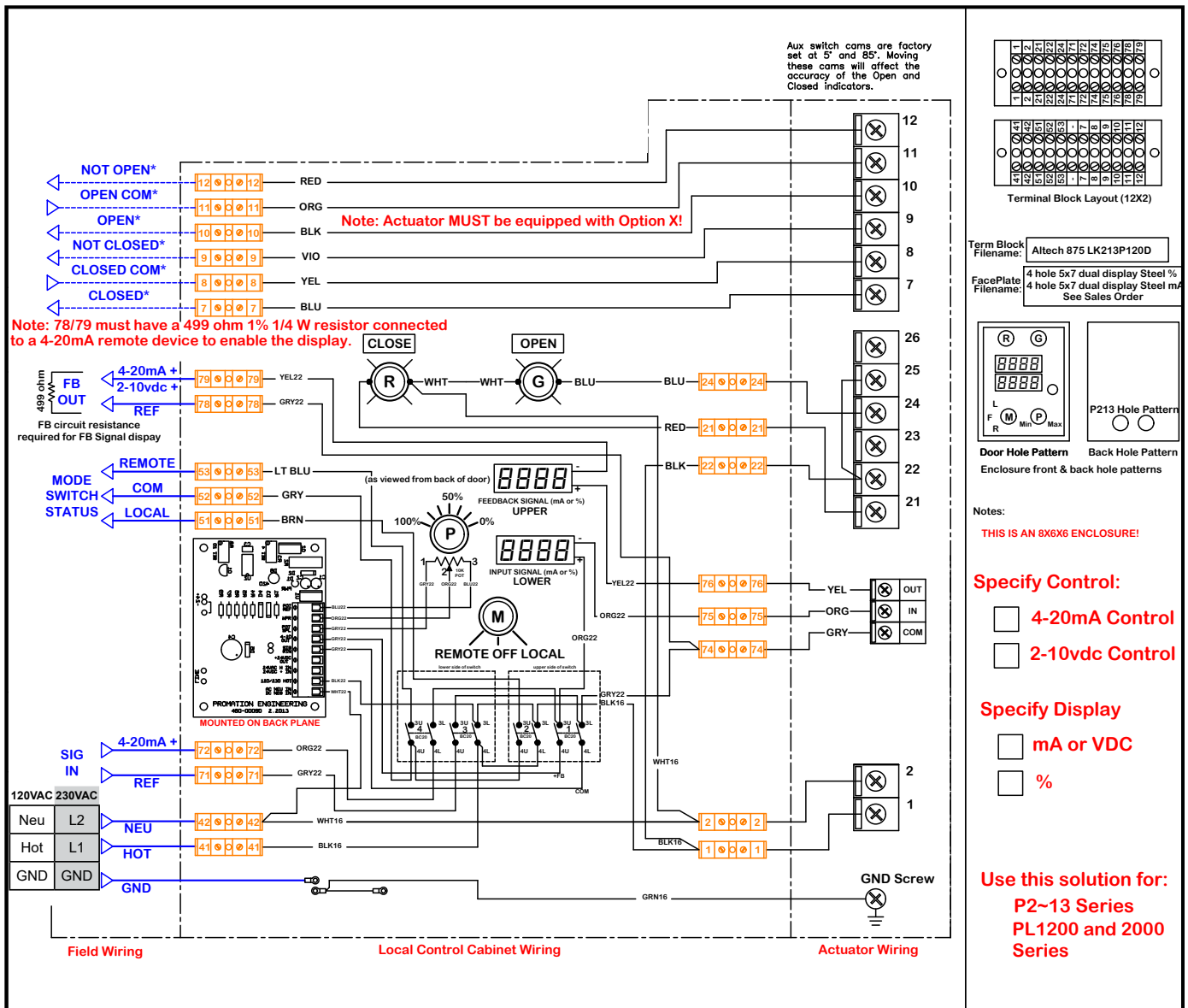

FM20_LCS_LE_G1_K_Ver C 011823

Component Identification

Controls - Front Panel

CLOSED (RED) indicator

Uses aux contacts from the actuator. When the MODE switch is set for LOCAL or REMOTE and the actuator is fully CLOSED, this indicator will illuminate.

OPEN (GRN) indicator

Uses aux contacts from the actuator. When the MODE switch is set for LOCAL or REMOTE and the actuator is fully OPEN, this indicator will illuminate.

Positioning Signal

LCD display shows the control signal being sent to the actuator and is automatically switched to REMOTE or LOCAL signal as a function of the MODE switch.



Latch

Quarter-turn, screwdriver access. Opens cabinet door to gain access to wiring terminal blocks and actuator wiring entry.

Feedback Signal

LCD display shows the feedback signal being generated by the actuator. The MODE switch must be in either REMOTE or LOCAL position for this display to function.

Local Positioning Knob

This weatherproof potentiometer knob controls the signal generator module inside the enclosure to generate the actuator positioning signal when the MODE switch is in the LOCAL position.

MODE Switch Knob

This selects the mode in which the actuator operates. In LOCAL mode, the front panel mounted potentiometer positions the actuator. In the REMOTE mode, the actuator positioning signal comes from the BAS or PLC system. MODE switch position has dry contacts in both active positions to allow remote monitoring of the MODE switch position.

WARNING!

The Mode switch does NOT function as a service disconnect!
Power is still present inside this enclosure when the mode switch is OFF.

Component Identification

Product Controls



LCS Model	LA	LB	LC	LD	LE	LF	LG	LH	LI	LJ	LK
Product	All	All	All	All	All	P1,PA,PL	P2-13	P1,PA,PL	P2-13	P1,PA, PL55, 11, 22, 44	P2-13 PL68, 12, 20
For On/Off/Jog Actuators Only	X	X	X	X							
For Proportional Actuators Only					X	X	X	X	X	X	X
Local/Off/Remote Mode Switch	X	X	X	X	X	X	X	X	X	X	X
Close-Stop-Open Switch	X	X	X	X							
Close-Open Switch (2 Pos)					X	X	X				
Close / Open Indicator Lights		X	X	X		X	X	X	X	X	X
End of Travel (EOT) Outputs to Controller		X	X	X		X	X	X	X	X	X
Mode Switch Position Signal to Controller			X	X		X	X	X	X	X	X
Illuminated Power Indicator				X		X	X				
Full Proportional Control via Potentiometer								X	X	X	X
LCD Display for Incoming Signal								X	X	X	X
LCD Display for Feedback Signal										X	X

Mechanical Data

Product Controls

SAMPLE DIAGRAM

LCS shown is only a sample and may not represent all components completely.

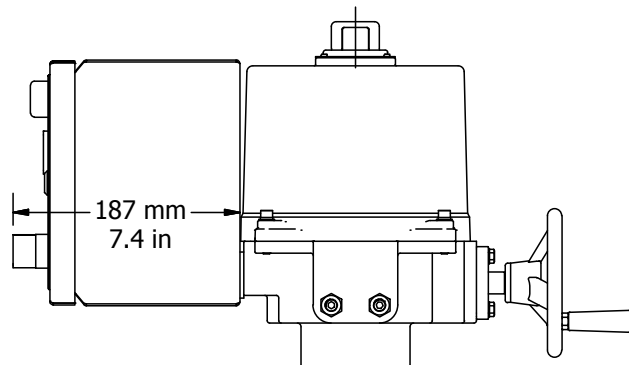
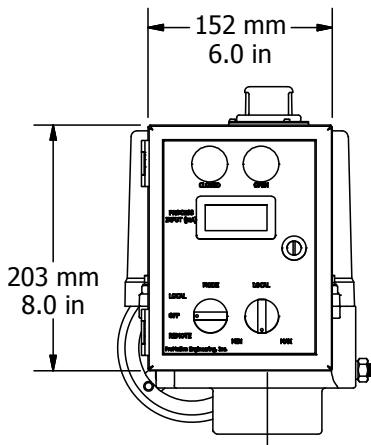
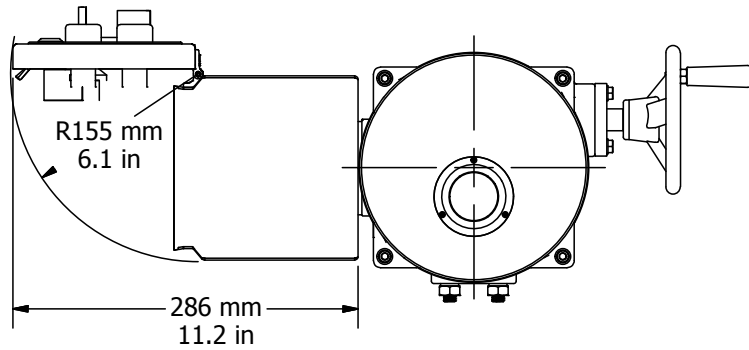
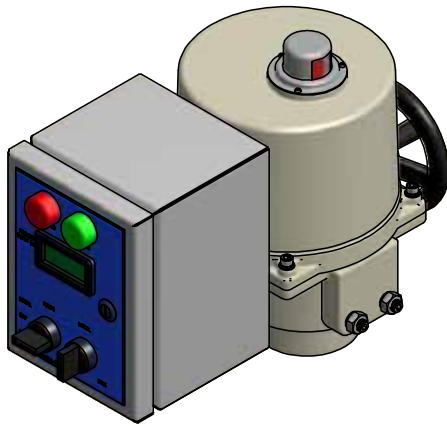

FM20 LCS_LE G1 K Ver C 011823