



PROMATION ENGINEERING

Precision Actuation for Industry

Installation & Operation Manual



This product is certified for use in the following hazardous locations:

Class I, Division 1, Groups C, D
Class II, Division 1, Groups E, F, and G
Class III; T6 (85 °C)

Ex d IIB Gb T6; Ex tb IIIC T85°C Db
Class I, Zone 1, AEx d IIB Gb T6
Zone 21, AEx tb IIIC T85°C Db

and requires procedures and equipment rated for installation in those areas.



This IOM is for the following
ProMation Engineering Products:

P4-120N7

P4-230N7

P5-120N7

P5-230N7

P6-120N7

P6-230N7

P4-120N7-TS

P4-230N7-TS

P5-120N7-TS

P5-230N7-TS

P6-120N7-TS

P6-230N7-TS

Hazardous Location Actuators

Product mounting, set up, and installation notes specific to Hazardous Location Actuators.

Operation and maintenance of a hazardous location actuator is the same as for an ordinary location actuator with the following amendments:

1. ONLY install a hazardous location actuator in a hazardous location for which the actuator was designed. The actuator is clearly marked with the classification for which it was designed and tested.
2. Mount, calibrate, and test actuators only during non-hazardous conditions.
3. Do NOT operate in ambient temperatures above +125° F (+52° C).
4. Do NOT, under any circumstances, remove the cover of the actuator while in a hazardous location with power still present inside the actuator. This could cause ignition of a hazardous atmosphere.
5. After removal of the cover care must be taken not to scratch, chip, or deform the mating surfaces of the cover and base of the actuator (see photos at right). Deformation to these surfaces negates the hazardous location rating of this actuator and the actuator should be removed from hazardous location service.
6. Mating surfaces of the cover and base must be cleaned before replacing cover. When replacing the actuator cover, carefully align the two pins (non-removable) embedded in the lower housing with the corresponding holes in the top housing. Fully seat the cover before tightening the cover bolts to avoid damaging the cover.
7. After securing the cover back onto the actuator there should be NO gaps larger than 0.003 in. (0.08mm) between the cover and the base of the actuator. This can be checked by a 0.003 in. thick by 1/2 in. wide feeler gauge which may not enter between the two faces more than 1/8 of an inch.
8. All electrical connections must be to national, state, and local codes and in accordance with hazardous location specifications for which this actuator is to be used.
9. Reducers, glands, and/or conduit must be appropriately certified to be used in hazardous locations.
10. To reduce the risk of ignition of hazardous atmospheres, an appropriately certified sealing fitting, cable gland or plug must be directly connected to the enclosure.
11. An unused conduit port must be sealed with an appropriately certified threaded blanking plug.
12. Under certain extreme circumstances, the non-metallic parts incorporated in the enclosure of this equipment may generate an ignition-capable level of electrostatic charge. Therefore the equipment shall not be installed in a location where the external conditions are conducive to the build-up of electrostatic charge on such surfaces. In addition, the equipment shall only be cleaned with a damp cloth.

Class I, Division 1, Groups C, D | Ex d IIB Gb T6; Ex tb IIIC T85°C Db
Class II, Division 1, Groups E, F, G | Class I, Zone 1, AEx d IIB Gb T6
Class III; T6 | Zone 21, AEx tb IIIC T85°C Db

CAUTION: To reduce the risk of ignition of hazardous atmospheres, disconnect the equipment from the supply circuit before opening. Keep assembly tightly closed when in operation. WARNING: To reduce the risk of ignition of hazardous atmospheres, an appropriately certified sealing fitting, cable gland or plug must be directly connected to the enclosure.

ATTENTION! Pour réduire le risque d'inflammation des atmosphères dangereuses, démontez l'équipement du circuit d'alimentation avant de l'ouvrir. Maintenez l'assemblage bien fermé lors de l'utilisation. MIS EN GARDE! Pour réduire le risque d'inflammation des atmosphères dangereuses, un joint d'étanchéité, un presse-étoupe ou une prise dûment certifié doit être lié à l'encastrement.

Plate found on actuator



Alignment pins/holes (refer to note 6) Mating Surfaces (refer to note 5, 6)



Feeler Gauge (refer to note 7)

FM15_P28 HV N7 (-TS) Ver. J_110519

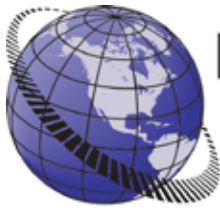

**PROMATION
ENGINEERING**

Precision Actuation for Industry

**Field Manual
P4/5/6 HV-N7(-TS)*
On/Off Control
ISO5211 F10 8P35**



* This IOM contains information for units both with and without Torque Switches.

Contents

2 Product Specifications
 3 Shipping and Handling
 3 Product Mounting and Setup
 3 Installation Notes
 4 Wiring Diagram
 4 Torque Switches
 5 Layout of Controller
 6 Check End of Travel Settings
 6 Status Indicators
 7 Adjusting the actuator CW position
 8 Adjusting the actuator CCW position
 9 Adjusting the actuator Auxiliary Switches
 10 Mechanical Data
 11 Mechanical Data
 12-14 Commissioning
 15 AutoCalibration Procedure

FMI_51002144416_16354410010519



Product Specifications

The “-TS” units are equipped with internal torque switches which protect the gear train, motor and controlled equipment from damage when high torque conditions exist.

These protective devices are NOT adjustable. More information on this technology is found throughout this manual.

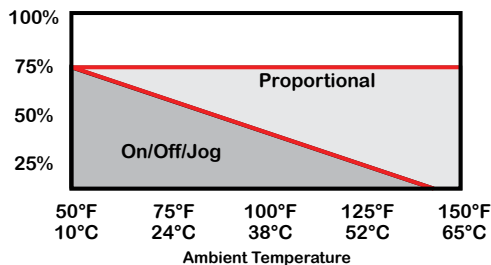

Actuator Specifications	P4		P5		P6	
Torque "lb/Nm	3500"lbs/400Nm		4400"lbs/500Nm		5750"lbs/650Nm	
Supply Voltage	120vac	230vac	120vac	230vac	120vac	230vac
Max Inrush Current	3.8A	2.0A	3.8A	2.0A	3.8A	2.0A
Running Current	1.9A	1.1A	2.0A	1.1A	2.1A	1.1A
Motor	Split Phase Capacitor					
Runtime (90°@60Hz/vdc)	16 sec		22 sec		28 sec	
Runtime (90°@50Hz)	18 sec		25 sec		31 sec	
Duty Cycle	25%					
Motor Starts	1200 per hour					
Weight	Non-TS: 52 lbs/ 24kg / TS: 59 lbs/ 27kg					
Mechanical Connections	ISO5211 F10 8pt 35mm					
Electrical Entry	(2) 3/4" NPT					
Electrical Terminations	12-16ga					
Environmental Rating	Class I Division 1, Class II Division 1					
Manual Override	7.6" Handwheel					
Control	On/Off/Jog					
Actuator Case material	Aluminum Alloy, Powder coated					
Motor Protection	230°F/110°C Thermal F* Class *Totally Enclosed Non-Ventilated Motors					
Ambient Temperature	-22°F to +125°F					
Operating Range	-30°C to +52°C					

Introduction

This document provides necessary information for set-up, calibration, testing and use of the P Series quarter-turn electric actuators stated on the cover page. Each unit is shipped from the factory with initial calibration of mechanical stops, cams and switches completed for 0-90 degree operation. However, these are general settings and serve as a starting point for proper calibration of the actuator in its real-world application.

Safety

Safety is a basic factor any time you maintain and operate mechanical equipment. Appropriate handling methods and proper use of tools and clothes can help prevent serious accidents -- accidents which can cause injuries to you or a fellow worker. This manual was created to enable a trained user to install, adjust and troubleshoot your ProMation actuator.

Only competent and trained personnel should install, maintain and operate ProMation Actuators. Any work related to this actuator must be carried out in accordance with this manual and related codes and regulations. Local workplace health and safety rules should always be followed.

Duty cycle

Duty cycle is the percent of time that an actuator spends running as a fraction of the total time. Duty Cycle is directly related to heat; excessively repositioning an actuator typically results in motor overheating which can cause permanent damage and/or reduced service life.

Duty cycle can be calculated as follows:

(example P2 series actuator running 3 seconds ON and 30 seconds OFF)

Runtime = 3s, Total time = 3s + 30s = 33s, therefore this duty cycle would be 9% (3/33)

Additionally, ProMation P series actuators are designed for a maximum of 1200 starts per hour (one start every 3 seconds maximum).

Shipping and Handling

1. This actuator is shipped in the FULLY CW position (2 color position indicator shows "CLOSE" and the Reference Dimple aligns with "0"). (The "1" mark is the FULLY CCW position).

2. **CONDUIT DEVICES MUST COMPLY WITH ALL APPLICABLE ELECTRICAL CODES FOR HAZARDOUS LOCATIONS.**

LES DISPOSITIFS DE CONDUIT DOIVENT ÊTRE CONFORMÉS DE TOUS LES CODES ÉLECTRIQUES APPLICABLES POUR LOCATIONS DANGEREUSES.

3. **Storage:** This unit should NOT be stored outside unless it is powered up and has proper conduit terminations. When NOT powered up, it should be stored in a clean, dry environment at all times.

4. This actuator has been **factory calibrated to operate between 0 degrees and 90 degrees. Most quarter-turn products will not require recalibration of these settings.** Check alignment of actuator and driven device. If any travel adjustment is necessary, please refer to pages 7-9 for instructions.

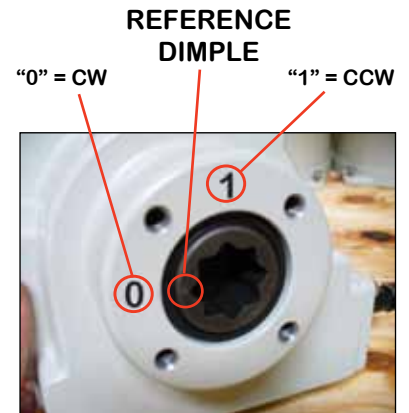

0 and 1 colored for clarity

Product Mounting and Setup

1. Fully CLOSE the valve or damper to which the actuator is to be mounted.
 - Keep in mind this actuator rotates CW (as viewed from above the unit) when driving CLOSED.
2. Assemble necessary linkage components and attach the actuator to the driven device.
3. Tighten mounting bolts, making sure actuator is centered on the device drive shaft.
4. Utilize the handwheel to check for unobstructed manual operation from fully CCW to fully CW positions BEFORE applying power to the unit.
5. Torque Switches (2), if so equipped, are factory set and **are NOT adjustable.**
6. Make the electrical connections per wiring diagram on page 5 or 6 depending on your model.
 - Connect POWER AND CONTROL to terminals marked 1, 2, 4, and 6.
 - Terminals 7-12 on the switch card (430-10100) are for the (adjustable) aux switches. They are dry type Form C rated 10A @ 250vac MAX.
7. Follow all rules and regulations for installing electrical equipment per applicable electrical code.
8. Do NOT apply power at this time.

Installation Notes

- These actuators are designed to be used between a horizontal and upright position. Do NOT mount the assembly with the actuator top below a horizontal position.
- When installing conduit, use proper techniques for entry into the actuator. Use drip loops to prevent conduit condensate from entering the actuator.
- Mechanical travel stops are factory calibrated for 90 degree operation. These stops are NOT designed to adjust mechanical rotation by more than +/- 3 degrees, they are for positioning the handwheel only.
- Both NPT conduit ports MUST use proper equipment to protect the rated integrity of the housing.
- The internal heater is to be used in ALL applications.
- Do NOT install the actuator outdoors or in humid environments unless it is powered up and the heater is functioning.
- Use proper wire size to prevent actuator failure (see chart on page 5 or 6 for proper wire sizing for your model).
- All terminals accept 12-16AWG solid/stranded wire.
- **Do NOT parallel wire multiple actuators together without utilizing isolation relays! Contact ProMation Engineering for a multiple actuator parallel wiring diagram.**
NE PAS mettre en parallèle des actionneurs multiples simultanément sans utiliser de relais d'isolement! Contactez ProMation Engineering pour un diagramme de câblage parallèle à plusieurs actionneurs.

Wiring Diagram for P4/5/6 Series

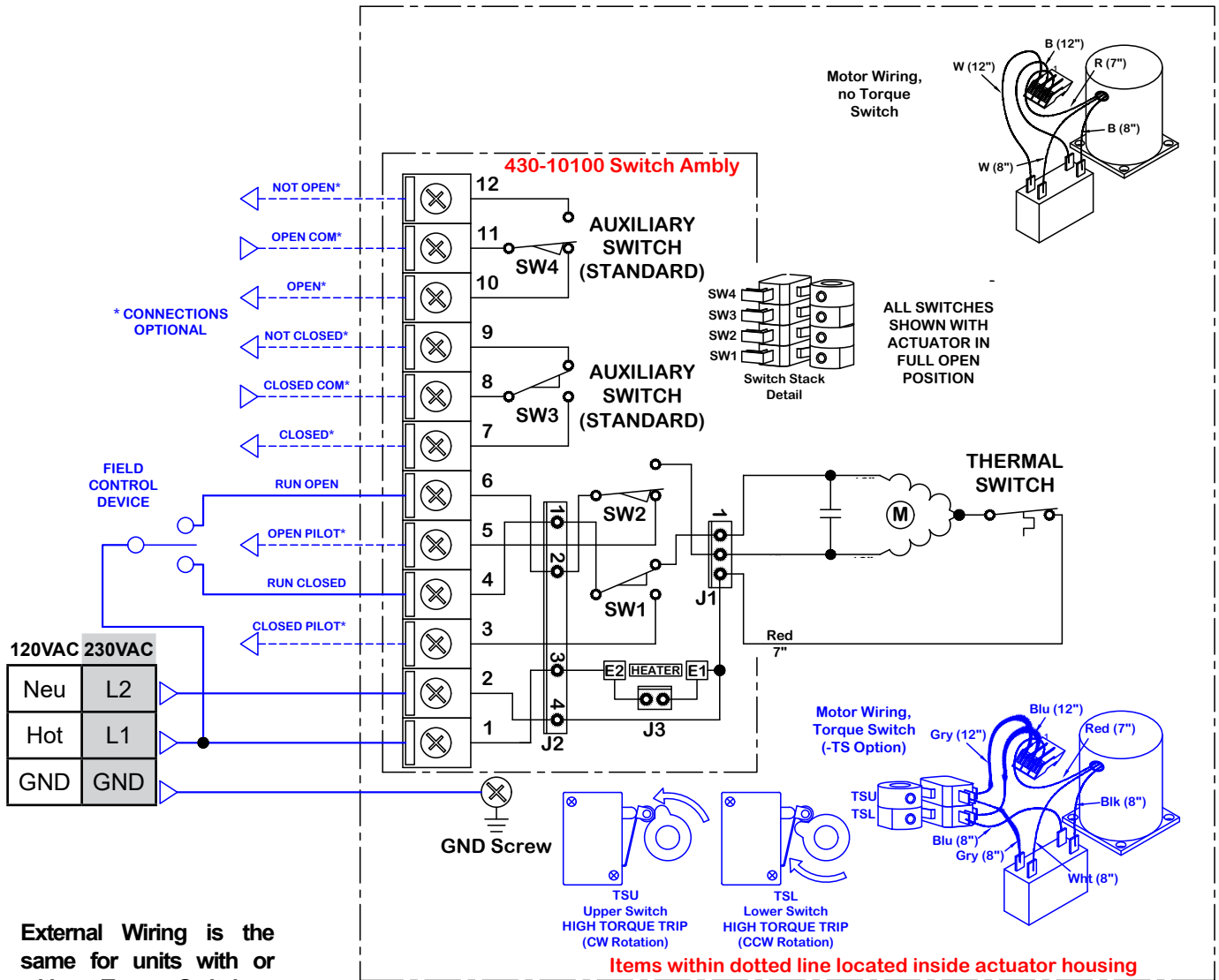

External Wiring is the same for units with or without Torque Switches.

Wire sizing data is provided in the table to assist in the selection of the proper wire size for ProMation actuators using various wire sizes over distance.

Please make sure to reference the correct voltage and do not exceed the indicated length of the wire run for each model.

SINGLE PHASE ONLY

Potential between L1 and L2 must be between 208 and 230VAC single phase

UNE SEULE PHASE SEULEMENT

Le potentiel entre L1 et L2 doit être compris entre 208 et 230 VAC en phase unique

Wire Sizing Chart

MAX distance between Actuator and Supply (feet)		
Actuator/ Voltage	P4/5/6 120VAC	P4/5/6 230VAC
Amps	3.8A	2.0A
Wire Gage		
16	342	1245
14	552	2010
12	844	3075
10	1435	5227
8	2142	7802



Wiring Diagram for P4/5/6-TS Series

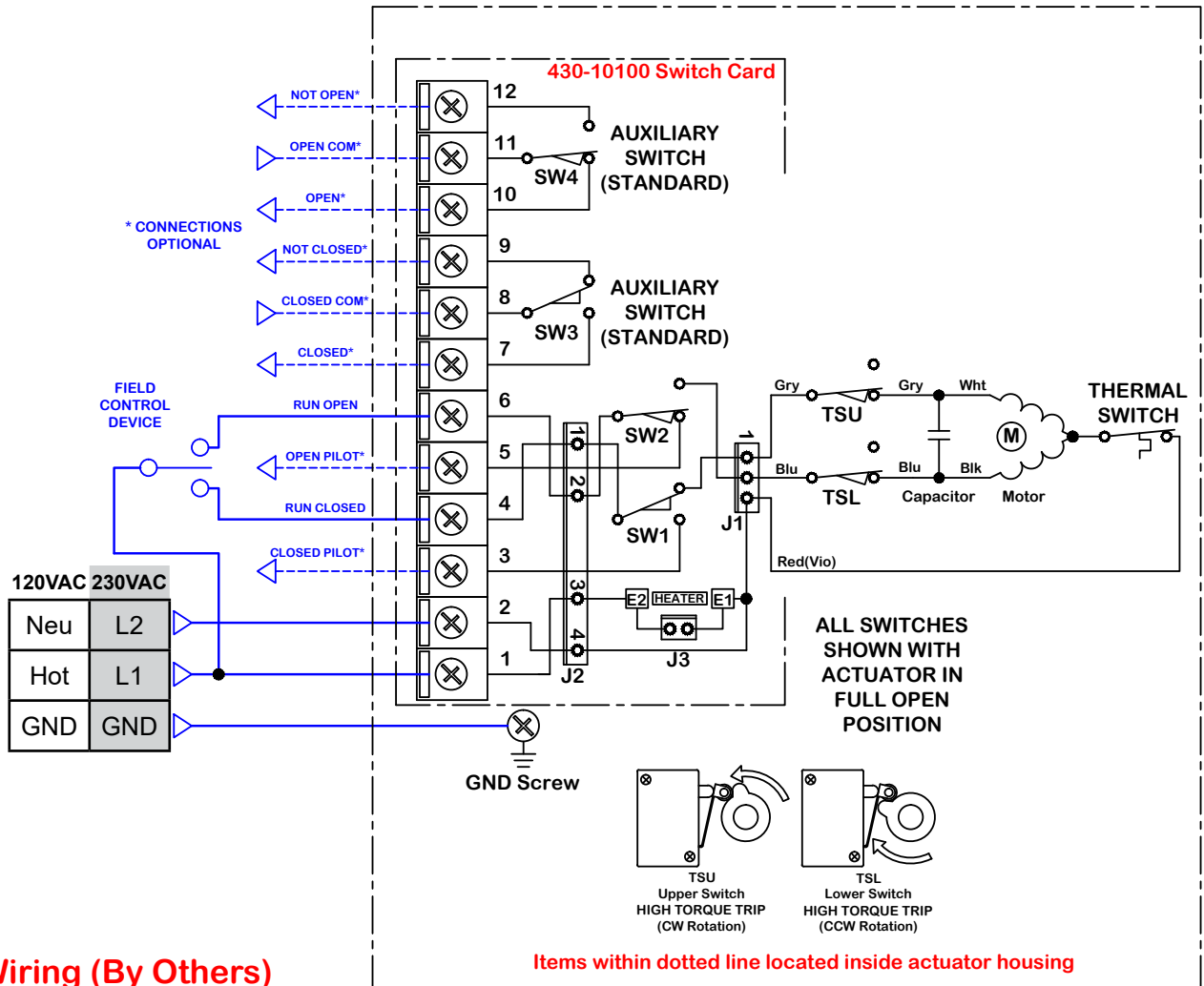

Field Wiring (By Others)

External Wiring is the same for units with or without Torque Switches.

Torque Switches

For units equipped with torque switches: Torque switches provide mechanical overload protection for both the actuated device and the geartrain.

These are factory set and are not adjustable without proper equipment. Torque switches are set to limit actuator torque to approximately 105% of the actuator rated output.

The wiring diagram above shows the internal wiring connections between the control board, the torque switches and the motor. The upper torque switch controls loading in the CW direction, while the lower switch controls loading in the CCW direction.

Identifying Torque Switch Units:

- TS in Product Name on label.
- Units with Torque Switches have additional switches mounted on the motor plate (see photo).



Wire sizing data is provided to assist in the selection of the proper wire size for ProMation actuators using various wire sizes over distance.

Please make sure to reference the correct voltage and do not exceed the indicated length of the wire run for each model.

WARNING! Do NOT adjust the torque switch cam settings. This will VOID the warranty.

. ATTENTION! NE PAS régler les réglages de came du couple. Cela annulera la garantie.

Adjusting the actuator CW position

Serious Damage to the actuator will result if the motor is allowed to drive the gear train into the mechanical stop!! Remove power from this device BEFORE making any travel adjustments.

This actuator has been factory calibrated to operate between 0 degrees and 90 degrees. Most quarter-turn products will not require recalibration of these settings. Proceed **ONLY** if adjustments are required.



CW Mechanical Stop

Loosen Mechanical Stop

1. BEFORE power is applied, use a 17mm wrench and a 5mm hex key to loosen the RIGHT SIDE mechanical stop. This is the CW stop limit adjustment. Turn the stop screw 5-6 turns CCW to allow electrical cam stop adjustment without running into the mechanical stop screw.
2. Use the manual hand wheel to position the actuator to your required CW position. This must be within +/- 3 degrees of the factory setting.

Adjust Cam 1

3. The lower cam is Cam 1, the CW end-of-travel adjustment. Once the actuator is at its required CW position, with POWER OFF, use a 2.5mm hex key to free up the cam set screw. Once it is free, rotate the hex key to the RIGHT 10-15 degrees to reset the switch roller arm. Then snug the set screw up against the camshaft (CW) until slight pressure is felt. Then SLOWLY rotate the hex key pushing the cam to the LEFT until you hear the "click" on the bottom switch indicating that correct adjustment has been achieved. Tighten the set screw.



Cam 1

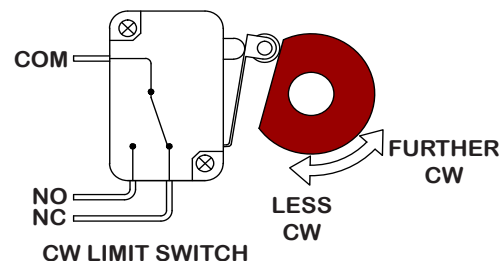

4. Apply power to the actuator and drive CCW at least 15-20 degrees. Then drive the actuator CW until the cam stops the electrical travel. Check to be sure this is the correct CW position you require. Repeat step 3 if further adjustment is needed.



CW Mechanical Stop

Tighten Mechanical Stop

5. While holding the 17mm wrench on the RIGHT SIDE jam nut to prevent the jam nut from locking, turn the 5mm hex key CW until the end of the stop screw bottoms out against the internal stop boss. Then turn the hex key ONE FULL TURN CCW before locking that adjustment with the jam nut. This procedure assures that the actuator reaches its end of travel electrically before there is any interference from the mechanical stop.
6. This completes the CW position calibration.

The mechanical stop screw limits handwheel operation ONLY and is NOT to be used as an electrical travel limiting device.

Adjusting the actuator CCW position

Serious Damage to the actuator will result if the motor is allowed to drive the gear train into the mechanical stop!! Remove power from this device BEFORE making any travel adjustments.

This actuator has been factory calibrated to operate between 0 degrees and 90 degrees. Most quarter-turn products will not require recalibration of these settings. Proceed **ONLY** if adjustments are required.



CCW Mechanical Stop

Loosen Mechanical Stop

1. BEFORE power is applied, use a 17mm wrench and a 5mm hex key to loosen the LEFT SIDE mechanical stop. This is the CCW stop limit adjustment. Turn the stop screw 5-6 turns CCW to allow electrical cam stop adjustment without running into the mechanical stop screw.
2. Use the manual hand wheel to position the actuator to your required CCW position. This must be within +/- 3 degrees of the factory setting.

Adjust Cam 2

3. The second cam is Cam 2, the CCW end-of-travel adjustment. Once the actuator is at its required CCW position, with POWER OFF, use a 2.5mm hex key to free up the cam set screw. Once it is free, rotate the hex key to the LEFT 10-15 degrees to reset the switch roller arm. Then snug the set screw up against the camshaft (CW) until slight pressure is felt. Then SLOWLY rotate the hex key pushing the cam to the RIGHT until you hear the "click" on the second switch indicating that correct adjustment has been achieved. Tighten the set screw.

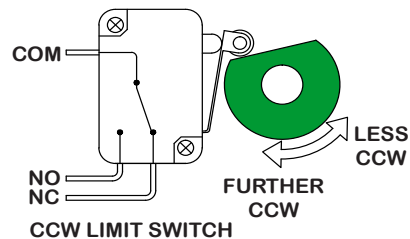

Cam 2

4. Apply power to the actuator and drive CW at least 15-20 degrees. Then drive the actuator CCW until the cam stops the electrical travel. Check to be sure this is the correct CCW position you require. Repeat step 3 if further adjustment is needed.

Tighten Mechanical Stop

5. While holding the 17mm wrench on the LEFT SIDE jam nut to prevent the jam nut from locking, turn the 5mm hex key CW until the end of the stop screw bottoms out against the internal stop boss. Then turn the hex key ONE FULL TURN CCW before locking that adjustment with the jam nut. This procedure assures that the actuator reaches its end of travel electrically before there is any interference from the mechanical stop.



CCW Mechanical Stop

6. This completes the CCW position calibration.

The mechanical stop screw limits handwheel operation ONLY and is NOT to be used as an electrical travel limiting device.

Adjusting the actuator Auxiliary Switches



Cam 3

Adjust Cam 3

1. The THIRD cam is Cam 3, the CW auxiliary switch adjustment. Drive the actuator to its CW position. Then use a 2.5mm hex key to free up the cam set screw. Once it is free, rotate the hex key to the RIGHT 10-15 degrees to reset the switch roller arm. Then snug the set screw up against the camshaft (CW) until slight pressure is felt. Then SLOWLY rotate the hex key and cam to the LEFT until you hear the “click” on the third switch. Continue to rotate the cam between 3 and 5 degrees to the LEFT to make sure the auxiliary cam switch changes state before the actuator reaches its end of travel electrically. Tighten the cam set screw.



Cam 4

Adjust Cam 4

1. The FOURTH cam is Cam 4, the CCW auxiliary switch adjustment. Drive the actuator to its CCW position. Then use a 2.5mm hex key to free up the cam set screw. Once it is free, rotate the hex key to the LEFT 10-15 degrees to reset the switch roller arm. Then snug the set screw up against the camshaft (CW) until slight pressure is felt. Then SLOWLY rotate the hex key to the RIGHT until you hear the “click” on the fourth switch. Continue to rotate the cam between 3 and 5 degrees to the RIGHT to make sure the auxiliary cam switch changes state before the actuator reaches its end of travel electrically. Tighten the cam set screw.

Mechanical Data

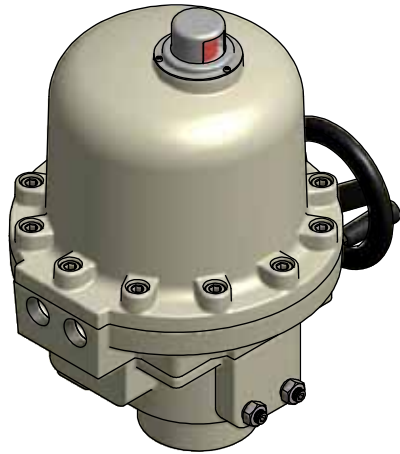

P2~8 EX-TS Series Dimensional Data

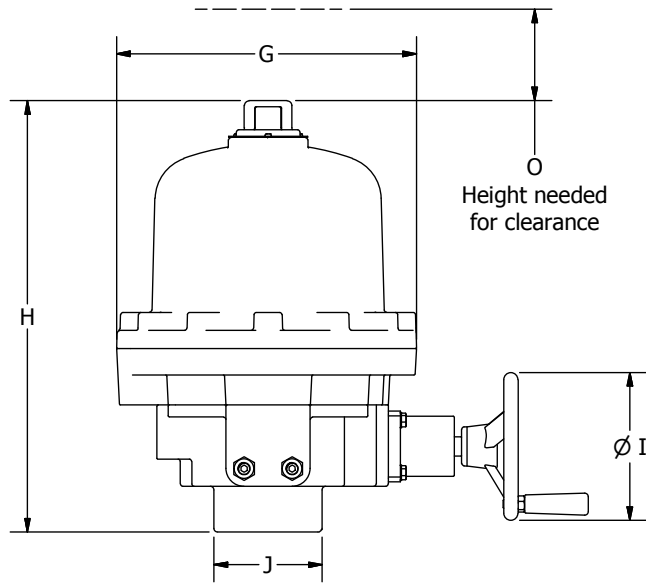
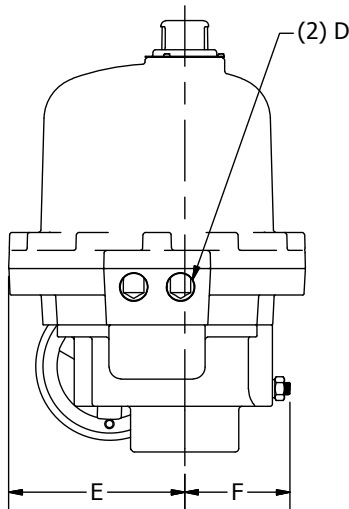
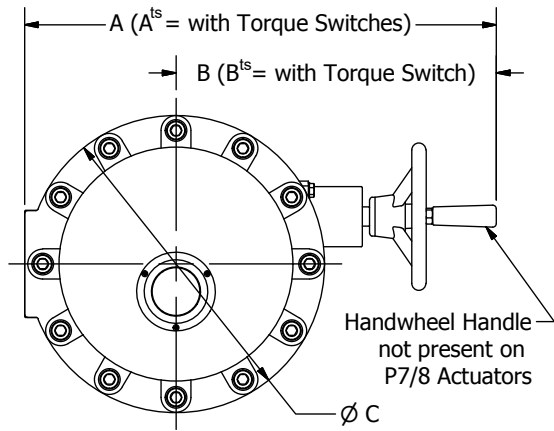

Drive Coupling Fabrication Data

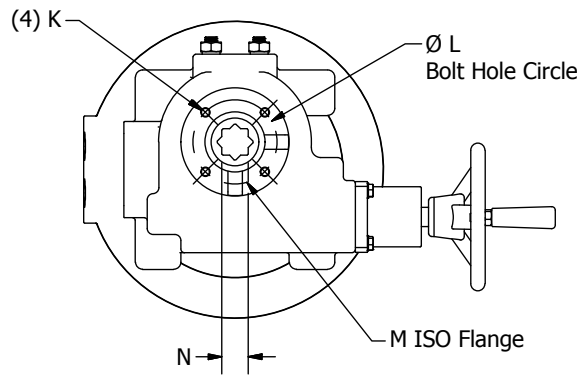
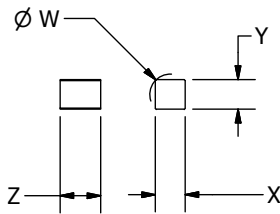

Dimensional Data P2~8-N7 Series Actuators: inches (mm)

	A	A ^{ts}	B	B ^{ts}	C	D	E	F	G	H	I
P2~P3	14.0 (355)	15.5 (392)	9.0 (229)	10.5 (267)	9.7 (247)	3/4" NPT	5.8 (146)	3.4 (88)	9.8 (249)	14.1 (359)	4.8 (123)
P4~P6	16.7 (423)	19.2 (488)	10.8 (275)	13.4 (340)	11.2 (285)	3/4" NPT	7.3 (184)	5.0 (126)	11.5 (291)	15.3 (389)	7.6 (194)
P7~P8	14.9 (377)	18.4 (468)	9.0 (226)	12.6 (320)	11.2 (285)	3/4" NPT	9.3 (236)	5.0 (126)	11.5 (291)	18.8 (478)	11.6 (295)
	J	K	L	M	N	O	W	X	Y	Z	
P2~P3	3.5 (90)	M8 - 1.25 x 0.8" D	2.8 (70)	F07	.866 (22.0)	8.0 (203)	1.18 (30.0)	.866 (22.0)	.866 (22.0)	1.18 (30.0)	
P4~P6	4.9 (125)	M10-1.50 x 0.8" D	4.0 (102)	F10	1.378 (35.0)	8.0 (203)	1.89 (48.0)	1.378 (35.0)	1.378 (35.0)	1.58 (40.0)	
P7~P8	7.1 (180)	M12-1.75 x 1.0" D	4.9 (125)	F12	1.417 (36.0)	8.0 (203)	1.93 (49.0)	1.417 (36.0)	1.417 (36.0)	1.77 (45.0)	

Dim X and Y Tolerance: +0.000" -0.005" (+0.00mm -0.13mm)

FM15_P28 HV N7 (-TS) Ver. J_110519



Mechanical Data



P Series Exploded View

(P2/3-120N7 unit is shown)

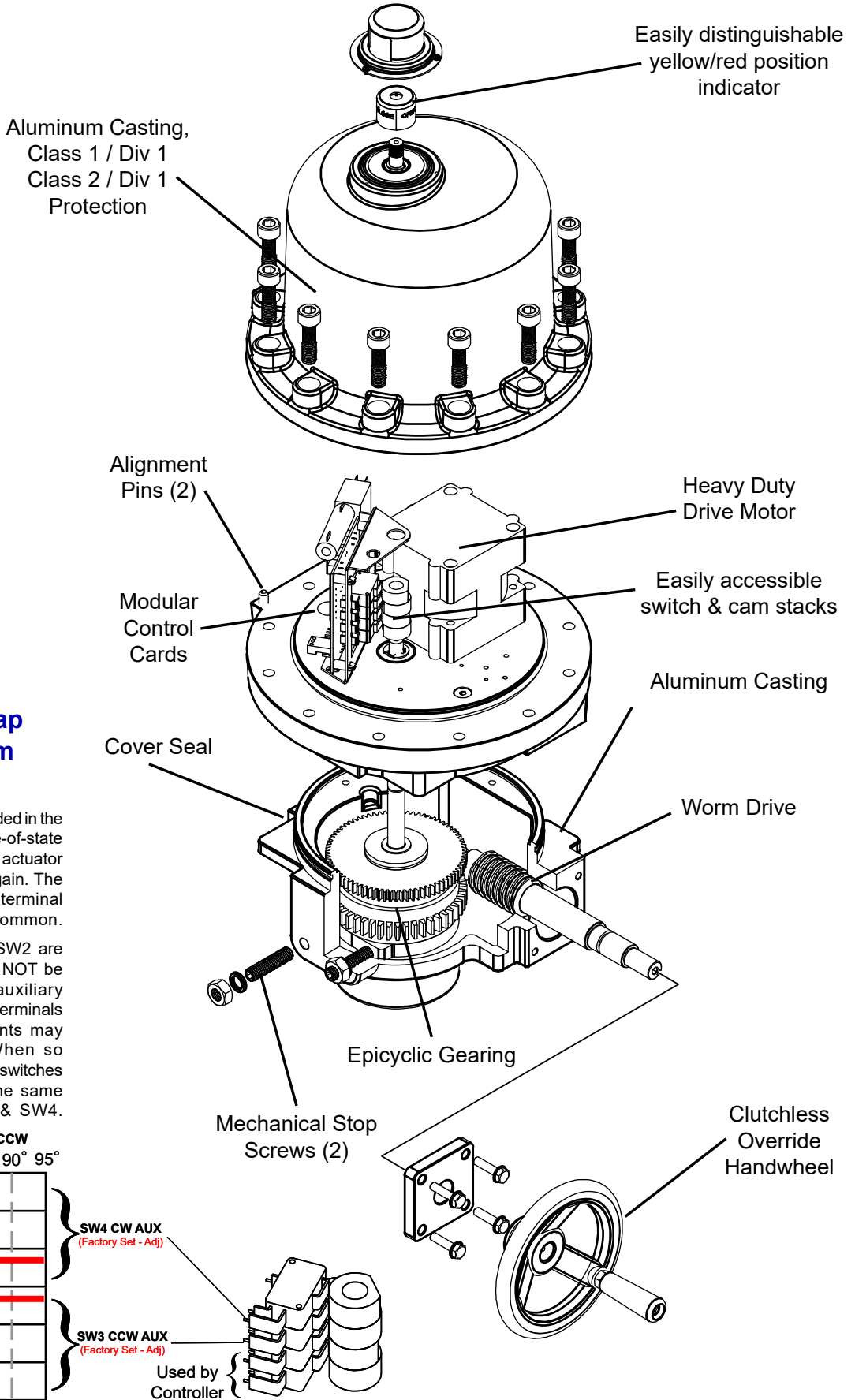

Switch Logic Map and Switch/Cam Arrangement

Switch sequencing data is provided in the table below to show the change-of-state points during the rotation of the actuator from CCW to CW and back again. The red bars indicate when that terminal makes with it's respective common.

Limit switches for SW1 and SW2 are set at the factory and should NOT be changed. The INCLUDED auxiliary switches SW3 & SW4 are for terminals 7 thru 12 and those set points may be modified if need be. When so optioned, SW5 & SW6 auxiliary switches are initially set to function the same as auxiliary switches SW3 & SW4.

Terminal ID#	CW			CCW		
	-5°	0°	5°	85°	90°	95°
12	Not Open					
11	Open Common					
10	Open					
9	Not Closed					
8	Closed Common					
7	Closed					

SW4 CW AUX (Factory Set - Adj)
 SW3 CCW AUX (Factory Set - Adj)
 Used by Controller

FM15_P28 HV N7 (-TS) Ver. J_110519



Commissioning

After completing all mounting and wiring procedures and main power is available, it is now possible to commission the actuator.

1. Utilize the handwheel to rotate the actuator and damper, valve or other connected device through its full travel from fully CW to fully CCW and back again to check for any possible interference.
 - Do NOT utilize any mechanical advantage devices to rotate the handwheel (pipes, wrenches, extension bars, etc.).
2. Manually position the actuator to its mid-stroke position.
3. Make certain the 3 wire orange plug is fully seated on the 3-pin receptacle on the switch board.
4. Apply correct power to the unit.
 - 4.A Measure correct power on terminals marked 1 and 2 on the switch board.
 - 4.B Measure correct power on the two heater terminals on the switch board.
5. Command the field device to generate a CCW signal. The actuator rotates in a CCW direction (as viewed from above).
 - Measure terminals 2 and 6 for correct voltage (matching that measured in step 4.A).
 - Actuator will stop when it reaches it's fully CCW position.
6. Command the field device to generate a CW signal. The actuator rotates in a CW direction (as viewed from above).
 - Measure terminals 2 and 4 for correct voltage (matching that measured in step 4.A).
 - Actuator will stop when it reaches it's fully CW position.
7. Actuator is now commissioned and operational.

Commissioning for TS units

After completing all mounting and wiring procedures and main power is available, it is now possible to commission the actuator.

- Utilize the handwheel to rotate the actuator and damper, valve or other connected device through its full travel from full CW to full CCW and back again to check for any possible interference. Do NOT utilize any mechanical advantage devices to rotate the handwheel (pipes, wrenches, extension bars, etc.).
- Manually position the actuator to its mid-stroke position.
- Make certain the 3 wire orange plug is fully seated on the 3-pin receptacle on the switch board.
- Apply correct power to the unit.
- Measure correct power on terminals 1 and 2 on the switch board.
- Measure correct power on the two heater terminals on the switch board.
- Command the field device to generate a CCW signal. The actuator rotates in a CCW direction (as viewed from above).
- Measure terminals 2 and 6 for correct voltage (matching that measured in step 5).
- Actuator will stop when it reaches it's full CCW position.
- This unit incorporates a torque overload protection system. In NORMAL operating mode, the torque switch drive cam is in this position:

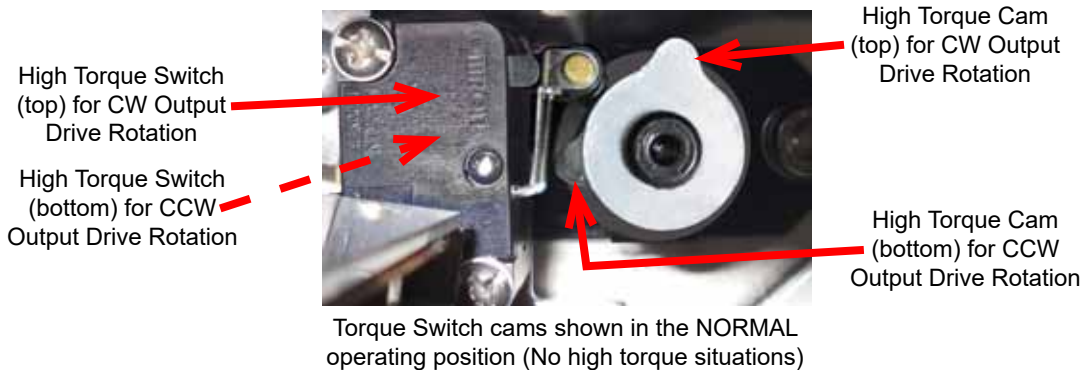

WARNING! Do NOT adjust the torque switch cam settings. This will VOID the warranty.

- Rotate the manual override handwheel in a CCW direction to continue to drive the output drive in a CCW direction until the drive system reaches the end of its MECHANICAL travel either by coming into contact with the mechanical stop screw OR it reaches the end of the valve (or damper) travel. This is indicative of an increasing force required to rotate the handwheel. At this point the torque switch cam shaft starts to rotate in a CW direction. As you continue to rotate the handwheel in the CCW direction the torque switch cam shaft will continue to rotate in the CW direction until the LOWER cam trips the LOWER high torque switch. At this point, stop rotating the handwheel as you've simulated reaching the electrical drive limit of the actuator under excessively high torque situations in the CCW output drive direction.

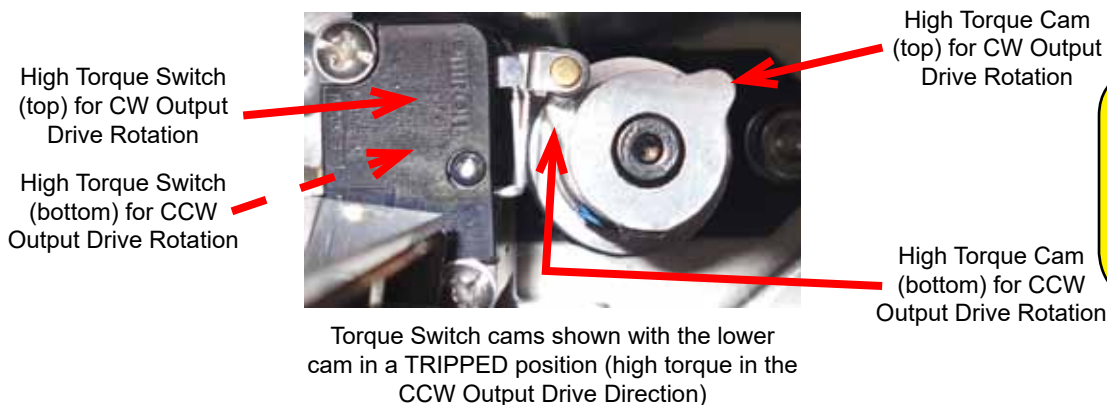

WARNING! Do NOT adjust the torque switch cam settings. This will VOID the warranty.

FM15_P28 HV N7 (-TS) Ver J_110519

Commissioning for TS units (continued)

12. Command the field device to generate a CW signal. The actuator rotates in a CW direction (as viewed from above).
13. Measure terminals 2 and 4 for correct voltage (matching that measured in step 5).
14. Actuator will stop when it reaches it's full CW position.
15. Rotate the manual override handwheel in a CW direction to continue to drive the output drive in a CW direction until the drive system reaches the end of its MECHANICAL travel either by coming into contact with the mechanical stop screw OR it reaches the end of the valve (or damper) travel. This is indicative of an increasing force required to rotate the handwheel. At this point the torque switch cam shaft starts to rotate in a CCW direction. As you continue to rotate the handwheel in the CW direction the torque switch cam shaft will continue to rotate in the CCW direction until the UPPER cam trips the UPPER high torque switch. At this point, stop rotating the handwheel as you've simulated reaching the electrical drive limit of the actuator under excessively high torque situations in the CW output drive direction.

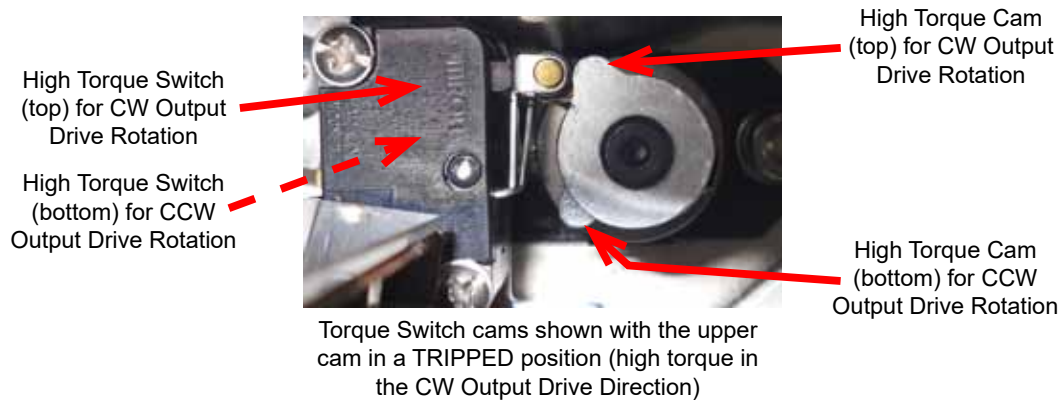

16. Generate a mid-position signal at the field device to move the actuator off its full CW trip position.
17. Actuator is now commissioned and operational.

