

PROMATION ENGINEERING

Precision Actuation for Industry

Installation & Operation Manual



This product is certified for use in the following hazardous locations:

Class I, Division 1, Groups C, D
Class II, Division 1, Groups E, F, and G
Class III; T6 (85 °C)

Ex d IIB Gb T6; Ex tb IIIC T85°C Db
Class I, Zone 1, AEx d IIB Gb T6
Zone 21, AEx tb IIIC T85°C Db

and requires procedures and equipment rated for installation in those areas.



This IOM is for the following
ProMation Engineering Products:

P4-120PN7

P4-230PN7

P5-120PN7

P5-230PN7

P6-120PN7

P6-230PN7

P4-120PN7-TS

P4-230PN7-TS

P5-120PN7-TS

P5-230PN7-TS

P6-120PN7-TS

P6-230PN7-TS

Hazardous Location Actuators

Product mounting, set up, and installation notes specific to Hazardous Location Actuators.

Operation and maintenance of a hazardous location actuator is the same as for an ordinary location actuator with the following amendments:

1. ONLY install a hazardous location actuator in a hazardous location for which the actuator was designed. The actuator is clearly marked with the classification for which it was designed and tested.

2. Mount, calibrate, and test actuators only during non-hazardous conditions.

3. Do NOT operate in ambient temperatures above +125° F (+52° C).

4. Do NOT, under any circumstances, remove the cover of the actuator while in a hazardous location with power still present inside the actuator. This could cause ignition of a hazardous atmosphere.

5. After removal of the cover care must be taken not to scratch, chip, or deform the mating surfaces of the cover and base of the actuator (see photos at right). Deformation to these surfaces negates the hazardous location rating of this actuator and the actuator should be removed from hazardous location service.

6. Mating surfaces of the cover and base must be cleaned before replacing cover. When replacing the actuator cover, carefully align the two pins (non-removable) embedded in the lower housing with the corresponding holes in the top housing. Fully seat the cover before tightening the cover bolts to avoid damaging the cover.

7. After securing the cover back onto the actuator there should be NO gaps larger than 0.003 in. (0.08mm) between the cover and the base of the actuator. This can be checked by a 0.003 in. thick by 1/2 in. wide feeler gauge which may not enter between the two faces more than 1/8 of an inch.

8. All electrical connections must be to national, state, and local codes and in accordance with hazardous location specifications for which this actuator is to be used.

9. Reducers, glands, and/or conduit must be appropriately certified to be used in hazardous locations.

10. To reduce the risk of ignition of hazardous atmospheres, an appropriately certified sealing fitting, cable gland or plug must be directly connected to the enclosure.

11. An unused conduit port must be sealed with an appropriately certified threaded blanking plug.

12. Under certain extreme circumstances, the non-metallic parts incorporated in the enclosure of this equipment may generate an ignition-capable level of electrostatic charge. Therefore the equipment shall not be installed in a location where the external conditions are conducive to the build-up of electrostatic charge on such surfaces. In addition, the equipment shall only be cleaned with a damp cloth.

Class I, Division 1, Groups C, D | Ex d IIB Gb T6; Ex tb IIIC T85° C Db
Class II, Division 1, Groups E, F, G | Class I, Zone 1, AEx d IIB Gb T6
Class III; T6 | Zone 21, AEx tb IIIC T85° C Db

CAUTION: To reduce the risk of ignition of hazardous atmospheres, disconnect the equipment from the supply circuit before opening. Keep assembly tightly closed when in operation. WARNING: To reduce the risk of ignition of hazardous atmospheres, an appropriately certified sealing fitting, cable gland or plug must be directly connected to the enclosure.

ATTENTION! Pour réduire le risque d'inflammation des atmosphères dangereuses, démontez l'équipement du circuit d'alimentation avant de l'ouvrir. Maintenez l'assemblage bien fermé lors de l'utilisation. MIS EN GARDE! Pour réduire le risque d'inflammation des atmosphères dangereuses, un joint d'étanchéité, un presse-étoupe ou une prise dûment certifié doit être lié à l'encastrement.

Plate found on actuator



Alignment pins/holes (refer to note 6) Mating Surfaces (refer to note 5, 6)



Feeler Gauge (refer to note 7)

FM_P28 HV PN7 (-TS) Ver J_073119

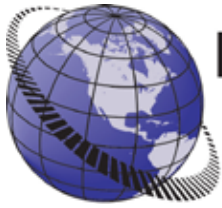

**PROMATION
ENGINEERING**
Precision Actuation for Industry

Field Manual
P4/5/6 HV-PN7(-TS)*
Proportional Control
ISO5211 F10 8P35



* This IOM contains information for units both with and without Torque Switches.

Table of Contents

1	Hazardous Location Actuators
3	Product Specifications
4	Shipping and Handling
4	Product Mounting and Setup
5	Wiring Diagram
7	Diagram of Controller
8	Controller: Initial Startup
8	Controller: Change INput/OUTput signal type
9	Controller: Adjusting the actuator CW position
10	Adjusting the actuator CW position
11	Controller: Adjusting the actuator CCW position
12	Adjusting the actuator CCW position
13	Controller: Change Loss of Signal Response Setting
14	Controller: Auto-Calibration Procedure
15	Adjusting the actuator Auxiliary Switches
16	Mechanical Data
17	Mechanical Data
18	Commissioning

FM_P28 HV-PN7(-TS) Ver. J_073119



Shipping and Handling

1. This actuator is shipped in the FULLY CW position (2 color position indicator shows "CLOSE" and the Reference Dimple aligns with "0"). (The "1" mark is the FULLY CCW position).

2. **CONDUIT DEVICES MUST COMPLY WITH ALL APPLICABLE ELECTRICAL CODES FOR HAZARDOUS LOCATIONS.**

LES DISPOSITIFS DE CONDUIT DOIVENT ÊTRE CONFORMÉS DE TOUS LES CODES ÉLECTRIQUES APPLICABLES POUR LOCATIONS DANGEREUSES.

3. **Storage: This unit should NOT be stored outside unless it is powered up and has proper conduit terminations. When NOT powered up, it should be stored in a clean, dry environment at all times.**

4. This actuator has been **factory calibrated to operate between 0 degrees and 90 degrees. Most quarter-turn products will not require recalibration of these settings.** Check alignment of actuator and driven device. If any travel adjustment is necessary, please refer to pages 8-14 for instructions.

5. **The actuator CANNOT operate with a rotation greater than 95 degrees without changing mechanical stops.**

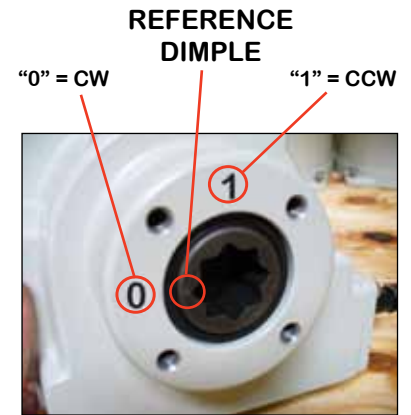

0 and 1 colored for clarity

Product Mounting and Setup

1. Fully CLOSE the valve or damper to which the actuator is to be mounted.

- Keep in mind this actuator rotates CW (as viewed from above the unit) when driving CLOSED.

2. Assemble necessary linkage components and attach the actuator to the driven device.

3. Tighten mounting bolts, making sure actuator is centered on the device drive shaft.

4. Utilize the handwheel to check for unobstructed manual operation from fully CCW to fully CW positions BEFORE applying power to the unit.

5. Make the electrical connections per wiring diagram on page 5.

- Connect POWER to terminals marked 1 and 2.
- Actuator accepts a 4-20mA (default), 0-10VDC, 1-5VDC, or 2-10VDC signal.
- Connect CONTROL wires on the control card (430-10102) to terminals marked ANALOG: IN and COM. The positive wire MUST connect to IN or the controller will not function.
- Wires may be connected on the control card (430-10102) to ANALOG: Out and COM for remote position sensing.
- Terminals 7-12 on the switch card (430-10100) are for the (adjustable) aux switches. They are dry type Form C rated 10A @ 250vac MAX.
- The drain wire on the signal cables must be grounded at ONE END ONLY! (Preferably at the supply end).

6. Do NOT apply power at this time.

Installation Notes

- These actuators are designed to be used between a horizontal and upright position. Do NOT mount the assembly with the actuator top below a horizontal position.
- When installing conduit, use proper techniques for entry into the actuator. Use drip loops to prevent conduit condensate from entering the actuator.
- Mechanical travel stops are factory calibrated for 90 degree operation. These stops are NOT designed to adjust mechanical rotation by more than +/- 3 degrees, they are for positioning the handwheel only.
- Both NPT conduit ports MUST use proper equipment to protect the rated integrity of the housing.
- The internal heater is to be used in ALL applications.
- Do NOT install the actuator outdoors or in humid environments unless it is powered up and the heater is functioning.
- Use proper wire size to prevent actuator failure (see chart on page 5).
- All terminals accept 12-16AWG solid/stranded wire.

Wiring Diagram for P4/5/6 Series

Proportional Control

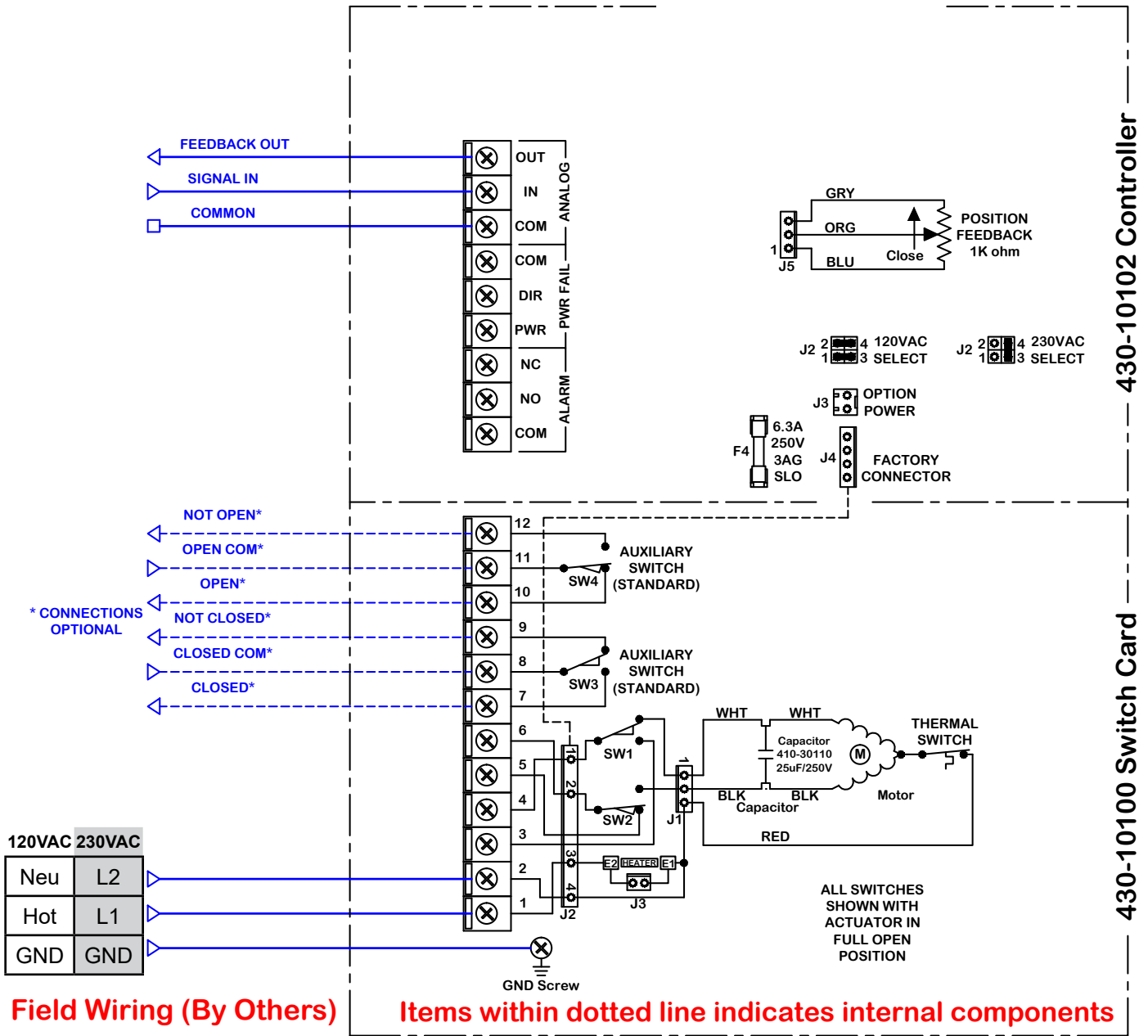

FM_P28 HV PN7 (-TS) Ver J_073119

SINGLE PHASE ONLY

Potential between L1 and L2 must be between 208 and 230VAC single phase

UNE SEULE PHASE SEULEMENT

Le potentiel entre L1 et L2 doit être compris entre 208 et 230 VAC en phase unique

Wire Sizing Chart

MAX distance between Actuator and Supply (feet)		
Actuator/ Voltage	P4/5/6 120VAC	P4/5/6 230VAC
Amps	3.8A	2.0A
Wire Gage		
16	342	1245
14	552	2010
12	844	3075
10	1435	5227
8	2142	7802

Wire sizing data is provided in the table to assist in the selection of the proper wire size for ProMation actuators using various wire sizes over distance.

Please make sure to reference the correct voltage and do not exceed the indicated length of the wire run for each model.



h	norming
g	norming
f	norming
e	norming
d	norming
c	norming
b	norming
a	norming
10/31/18	norming
CHANGE	norming
DATE	norming
revision	norming
norme	norming
11/5/2019 9:47 AM	norming
WD-850-P4100.dwg	norming
On/Off wiring diagram for 120vac	norming
P2 thru 8 N4 AND N7 actuators w/TS opt	norming
REV	norming
A	norming

SINGLE PHASE ONLY
Potential between L1 and L2 must be between 208 and 230VAC single phase
UNE SEULE PHASE SEULEMENT
Le potentiel entre L1 et L2 doit être compris entre 208 et 230 VAC en phase unique

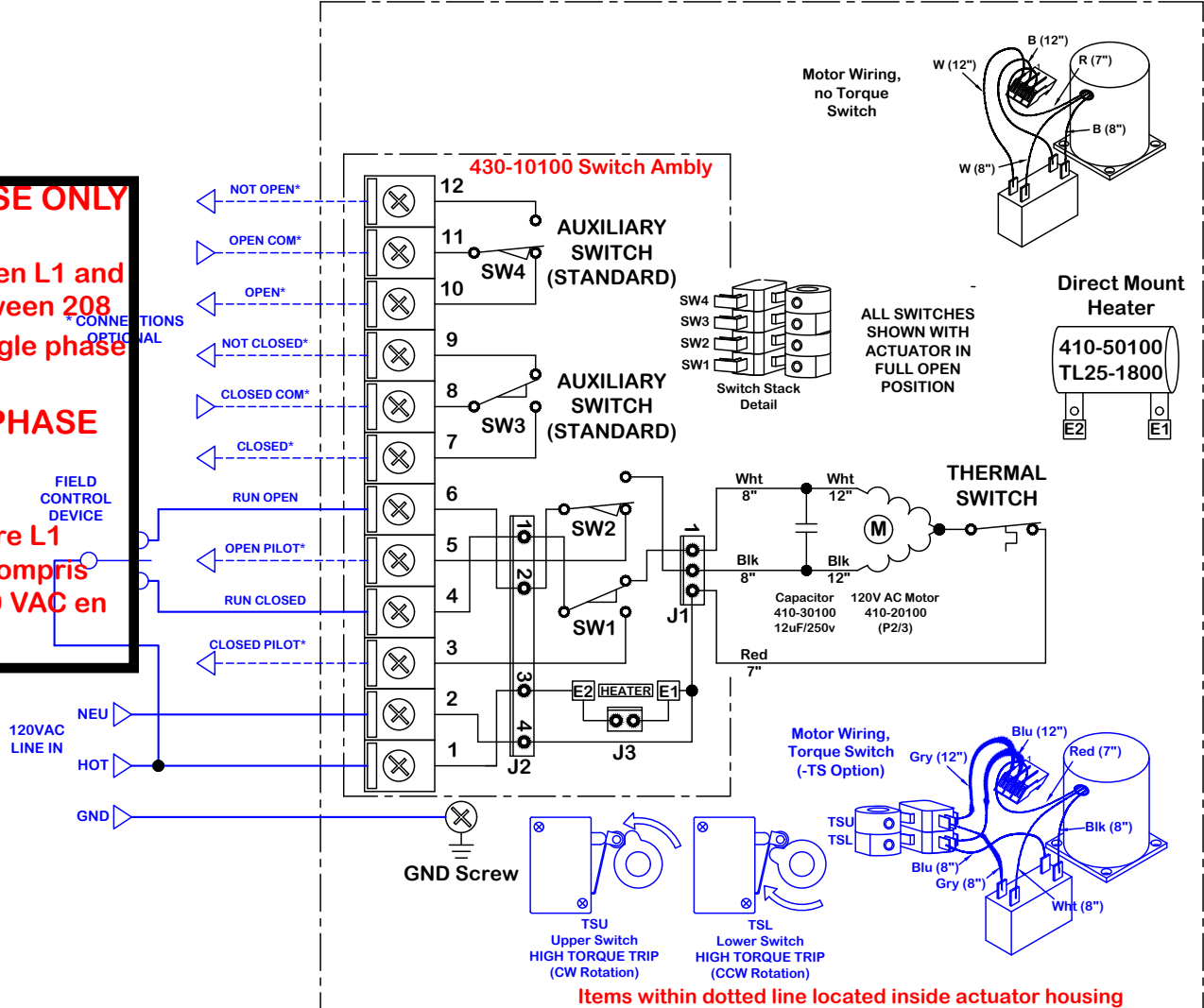

Actuator ships in fully closed position!

Use For:
P2-8 -120N4/N7 -(TS)

This document is the property of ProMation Engineering, Inc. Distribution of this document without the written consent of the owner is strictly forbidden. Failure to comply will incur a liability for damages.



P28 HV PN7 (-TS) Ver J_073119

Diagram of Controller

Proportional Control

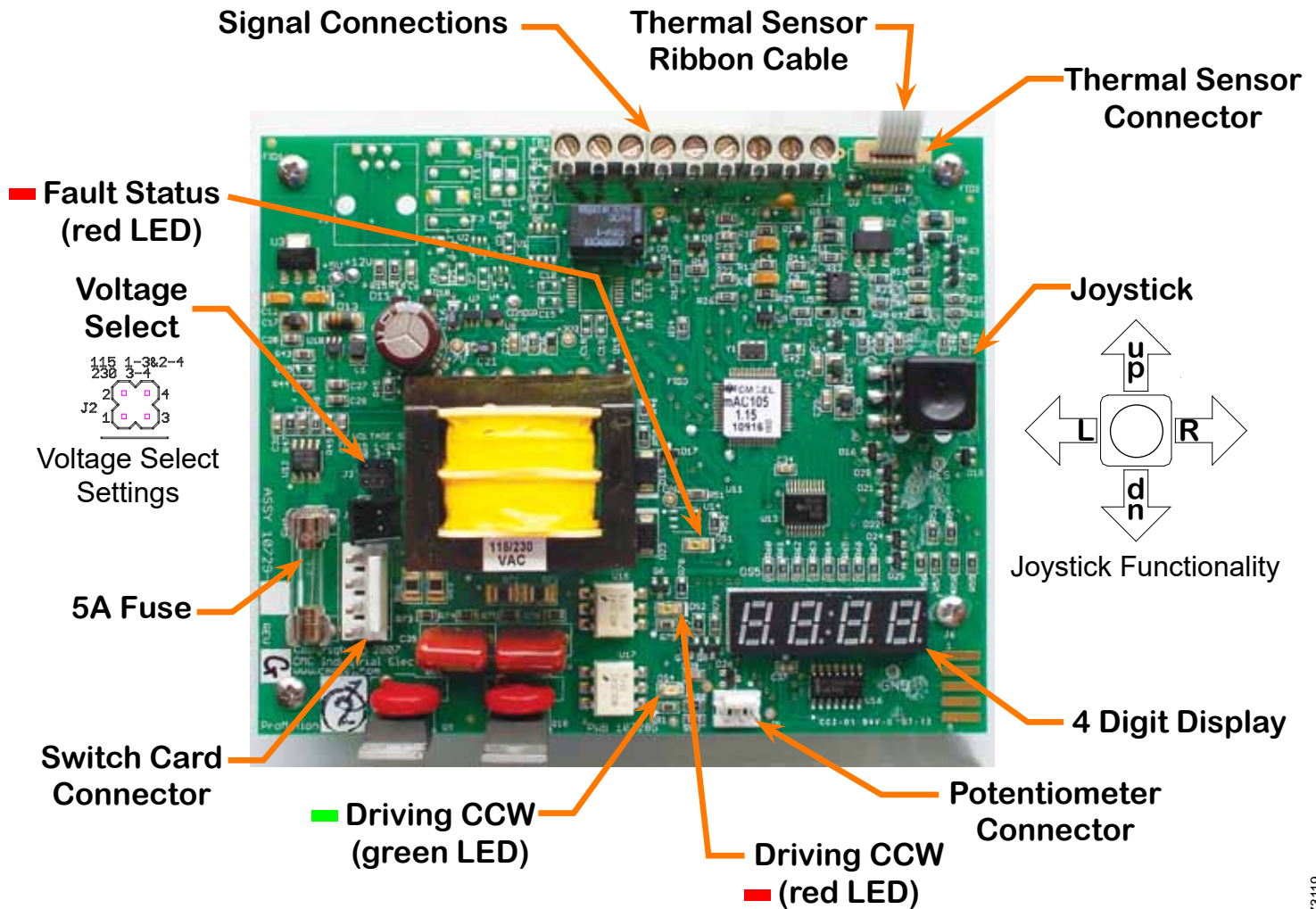

The proportional control card has been calibrated and tested at the factory to operate between 0 degrees and 90 degrees operating range. There is normally no need for any adjustments at this point in the installation. Changes from the factory set cam settings and controller settings can be very difficult to reverse.

The default settings in the controller are as follows:

- Input/Output Signal: 4-20mA (unless otherwise specified at time of Factory order)
- Signal Response: Direct Acting (max signal = CCW)
- Loss of Signal: Fail in Position
- Controller version: 1.15

The **Fault Status** indicator will blink once per second under normal operating conditions. It will blink approximately three times per second if a fault has occurred. A fault status indication will not return to normal unless the fault has been cleared or the board has been powered down.

Under normal operation, the **4 digit display** will show percentage of CCW position...i.e. 25 = 25% CCW of the full rotation.

82.50

Controller: Initial Startup

These instructions illustrate the initial power up sequence for power up, initial data displays, and position display so the user has a baseline for proper startup sequencing.

(Assumes actuator is properly mounted and wired as directed elsewhere in this manual).

Power Up (baseline of normal functionality):	4 digit display reads:	How the display behaves	Notes
1. Apply power to the actuator and wait 20 seconds for the controller to power up, self-test, and stabilize.		(Blank display before power up)	Power off
2. Immediately on power up the fault status light will begin blinking at a rate of once per second throughout operation		(Static display for about 1 second)	Initial power on display test of all led elements
3. The 4 digit display will begin sequencing through the self-test messaging.		(Text 'crawls' left to right. Displays twice.)	Software version (in this example: Version 1.15)
4. Because there are only 4 display characters the text will scroll or crawl across the display.		(Text 'crawls' left to right. Displays twice.)	Actuator - Voltage (in this example: P2 Actuator - 120 volt)
5. At this point the actuator is functioning properly.		(Static display, stays on.)	Rotation display showing 0.0% CCW
6. Note: Autocalibrating AFTER any controller modifications wipes out those modifications and the controller starts from it's new zero point.			

Controller: Change INput/OUTput signal type

Follow these instructions to change the input/output signal range or type:

(Assumes actuator is powered up, running and is at the default display showing position).

Press the joystick LEFT twice...	Display reads:
Press the joystick DOWN twice...	Display reads:
Press the joystick RIGHT once...	Display reads:
Press the joystick RIGHT again... Press the joystick UP or DOWN to toggle the display to available selections...	Display reads:
When the correct INPUT signal is displayed, press the joystick IN...	Display reads:
Press the joystick LEFT twice...	Display reads:
Press the joystick UP twice...	Display reads:
Press the joystick RIGHT once... DOWN twice, then RIGHT once, the display will now show % of CCW position (0.0 = CLOSED)	

Controller: Adjusting the actuator CW position

Follow these instructions to adjust the CW position controlled by the 105 Proportional Controller (standard operation). Proceed to the next page to adjust the CW position controlled by the travel cam.

(Assumes actuator is powered up, running and is at the default display, showing position).

Press the joystick LEFT twice...	Display reads:	rEdLt, NE
Press the joystick DOWN three times...	Display reads:	SEt tRdUeL
Press the joystick RIGHT once...	Display reads:	AutO SEt
Press the joystick DOWN once...	Display reads:	FULL CLoSEd
Press the joystick RIGHT once... (actual position in steps)	Display reads:	00 to 4096

Press joystick UP and HOLD to drive further CCW or press DOWN and HOLD to drive further CLOSED. The adjusted CLOSED position MUST be between 50 and 1000 steps.

When the correct CLOSED position is established, press the joystick IN...	Display reads:	done
Press the joystick LEFT twice...	Display reads:	SEt tRdUeL
Press the joystick UP three times	Display reads:	rEdLt, NE
Press the joystick RIGHT once... DOWN twice, then RIGHT once, the display will now show % of CCW position (0.0 = Fully CW)		00 to 100

Notice Performing an Auto Calibration after this procedure will ERASE this custom stop set point and will return to the factory default setting. For this reason, you CANNOT run an Auto Calibration procedure at any time after this setting has been changed.

Adjusting the actuator CW position

Serious Damage to the actuator will result if the motor is allowed to drive the gear train into the mechanical stop!! Remove power from this device BEFORE making any travel adjustments.

This actuator has been factory calibrated to operate between 0 degrees and 90 degrees. Most quarter-turn products will not require recalibration of these settings. Proceed **ONLY** if adjustments are required.



CW Mechanical Stop



Cam 1



CW Mechanical Stop

Loosen Mechanical Stop

1. BEFORE power is applied, use a 17mm wrench and a 5mm hex key to loosen the RIGHT SIDE mechanical stop. This is the CW stop limit adjustment. Turn the stop screw 5-6 turns CCW to allow electrical cam stop adjustment without running into the mechanical stop screw.
2. Use the manual hand wheel to position the actuator to your required CW position. This must be within +/- 3 degrees of the factory setting.

Adjust Cam 1

3. The lower cam is Cam 1, the CW end-of-travel adjustment. Once the actuator is at its required CW position, with POWER OFF, use a 2.5mm hex key to free up the cam set screw. Once it is free, rotate the hex key to the RIGHT 10-15 degrees to reset the switch roller arm. Then snug the set screw up against the camshaft (CW) until slight pressure is felt. Then SLOWLY rotate the hex key pushing the cam to the LEFT until you hear the "click" on the bottom switch indicating that correct adjustment has been achieved. Tighten the set screw.

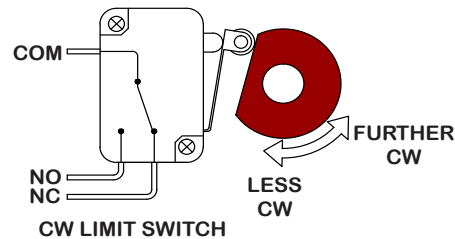

4. Apply power to the actuator and drive CCW at least 15-20 degrees. Then drive the actuator CW until the cam stops the electrical travel. Check to be sure this is the correct CW position you require. Repeat step 3 if further adjustment is needed.

Tighten Mechanical Stop

5. While holding the 17mm wrench on the RIGHT SIDE jam nut to prevent the jam nut from locking, turn the 5mm hex key CW until the end of the stop screw bottoms out against the internal stop boss. Then turn the hex key ONE FULL TURN CCW before locking that adjustment with the jam nut. This procedure assures that the actuator reaches its end of travel electrically before there is any interference from the mechanical stop.
6. This completes the CW position calibration.

Notice! After completing this step, you must initiate a recalibration routine (see AutoCalibration Procedures) in order for the changes to take effect in the controller.

Potentiometer Gear Engagement

During the setting of the CW stop position, make sure that the potentiometer pinion gear and the camshaft sector gear do not drive past the point of engagement. If the sector gear does not have at least 2 full teeth contacting the potentiometer pinion gear, contact your distributor for mechanical recalibration instructions.

The mechanical stop screw limits handwheel operation ONLY and is NOT to be used as an electrical travel limiting device.



Controller: Adjusting the actuator CCW position

Follow these instructions to adjust the CCW position controlled by the 105 Proportional Controller (standard operation). Proceed to the next page to adjust the CCW position controlled by the travel cam.

(Assumes actuator is powered up, running and is at the default display, showing position).

Press the joystick LEFT twice...	Display reads:	<i>rEdLt, nE</i>
Press the joystick DOWN three times...	Display reads:	<i>SEt tRduEL</i>
Press the joystick RIGHT once...	Display reads:	<i>AutO SEt</i>
Press the joystick DOWN twice...	Display reads:	<i>FULL oPEn</i>
Press the joystick RIGHT once... (actual position in steps)	Display reads:	<i>00 to 4096</i>

Press joystick UP and HOLD to drive further CCW or press DOWN and HOLD to drive further CW. The adjusted CCW position MUST be between 2500 and 4000 steps.

When the correct CCW position is established, press the joystick IN...	Display reads:	<i>done</i>
Press the joystick LEFT twice...	Display reads:	<i>SEt tRduEL</i>
Press the joystick UP three times	Display reads:	<i>rEdLt, nE</i>
Press the joystick RIGHT once... DOWN twice, then RIGHT once, the display will now show % of CCW position (0.0 = Fully CW)		<i>00 to 100</i>

Notice Performing an Auto Calibration after this procedure will ERASE this custom stop set point and will return to the factory default setting. For this reason, you CANNOT run an Auto Calibration procedure at any time after this setting has been changed.

Adjusting the actuator CCW position

Serious Damage to the actuator will result if the motor is allowed to drive the gear train into the mechanical stop!! Remove power from this device BEFORE making any travel adjustments.

This actuator has been factory calibrated to operate between 0 degrees and 90 degrees. Most quarter-turn products will not require recalibration of these settings. Proceed **ONLY** if adjustments are required.



CCW Mechanical Stop



Cam 2



CCW Mechanical Stop

Loosen Mechanical Stop

1. BEFORE power is applied, use a 17mm wrench and a 5mm hex key to loosen the LEFT SIDE mechanical stop. This is the CCW stop limit adjustment. Turn the stop screw 5-6 turns CCW to allow electrical cam stop adjustment without running into the mechanical stop screw.
2. Use the manual hand wheel to position the actuator to your required CCW position. This must be within +/- 3 degrees of the factory setting.

Adjust Cam 2

3. The second cam is Cam 2, the CCW end-of-travel adjustment. Once the actuator is at its required CCW position, with POWER OFF, use a 2.5mm hex key to free up the cam set screw. Once it is free, rotate the hex key to the LEFT 10-15 degrees to reset the switch roller arm. Then snug the set screw up against the camshaft (CW) until slight pressure is felt. Then SLOWLY rotate the hex key pushing the cam to the RIGHT until you hear the "click" on the second switch indicating that correct adjustment has been achieved. Tighten the set screw.

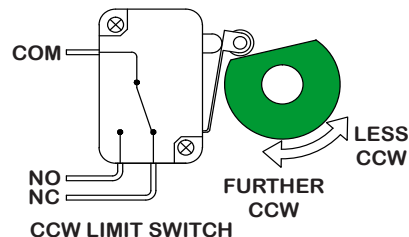

4. Apply power to the actuator and drive CW at least 15-20 degrees. Then drive the actuator CCW until the cam stops the electrical travel. Check to be sure this is the correct CCW position you require. Repeat step 3 if further adjustment is needed.

Tighten Mechanical Stop

5. While holding the 17mm wrench on the LEFT SIDE jam nut to prevent the jam nut from locking, turn the 5mm hex key CW until the end of the stop screw bottoms out against the internal stop boss. Then turn the hex key ONE FULL TURN CCW before locking that adjustment with the jam nut. This procedure assures that the actuator reaches its end of travel electrically before there is any interference from the mechanical stop.
6. This completes the CCW position calibration.

Notice! After completing this step, you must initiate a recalibration routine (see Auto-Calibration Procedures) in order for the changes to take effect in the controller.

Controller: Change Loss of Signal Response Setting

(Assumes actuator is powered up, running and is at the default display, showing position).

Notice: Any changes, settings or new calibration points are lost if a factory "Reset" is performed on the controller. Contact the factory for details.

Press the joystick LEFT twice...	Display reads:	rEALt, NE
Press the joystick DOWN twice...	Display reads:	SEt ProcESS
Press the joystick RIGHT once...	Display reads:	in dnd out
Press the joystick DOWN once...	Display reads:	INPUt FAULt
Press the Joystick RIGHT once...	Display reads:	FAULt LEvEL
Press the Joystick DOWN once...	Display reads:	FAULt PoSi, ti on
Press the Joystick RIGHT once...	Display reads:	-0.1
Press the joystick UP or DOWN to select	Display reads:	-0.1 to 100.0

{The display shows percentage of full CCW. i.e. 100.0 = full CCW.
50.0 = 50% CCW, 0.0 = Full CW. -0.1 = Fail in position (no move)}

After selection is displayed, press the joystick IN...

	Display reads:	done
Press the joystick LEFT three times...	Display reads:	SEt ProcESS
Press the joystick UP twice...	Display reads:	rEALt, NE
Press the joystick RIGHT once... DOWN twice, then RIGHT once, the display will now show % of CCW position (0.0 = Fully CW)		00 to 100

Controller: Auto-Calibration Procedure

(Assumes actuator is powered up, running and is at the default display, showing position).

Notice: Any changes, settings or new calibration points are lost if a factory "Reset" is performed on the controller. Contact the factory for details.

Press the joystick LEFT twice...

Display reads: *rEdLt, NE*

Press the joystick DOWN three times...

Display reads: *SEt tRdUeL*

Press the joystick RIGHT once...

Display reads: *Auto SEt*

Press the joystick RIGHT once...

Display reads: *PUSH to rUn*

Press the joystick IN. The display will show calibration routines AC1 through AC10, moving the actuator to different positions and recording data at each step. When the auto calibration routine is complete, the actuator will be in the fully CW position, and the display will read:

done

Press the joystick LEFT twice...

Display reads: *SEt tRdUeL*

Press the joystick UP three times

Display reads: *rEdLt, NE*

Press the joystick RIGHT once... DOWN twice, then RIGHT once, the display will now show % of CCW position (0.0 = Fully CW)

00 to 100

Adjusting the actuator Auxiliary Switches



Cam 3

Adjust Cam 3

1. The THIRD cam is Cam 3, the CW auxiliary switch adjustment. Drive the actuator to its CW position. Then use a 2.5mm hex key to free up the cam set screw. Once it is free, rotate the hex key to the RIGHT 10-15 degrees to reset the switch roller arm. Then snug the set screw up against the camshaft (CW) until slight pressure is felt. Then SLOWLY rotate the hex key and cam to the LEFT until you hear the “click” on the third switch. Continue to rotate the cam between 3 and 5 degrees to the LEFT to make sure the auxiliary cam switch changes state before the actuator reaches its end of travel electrically. Tighten the cam set screw.



Cam 4

Adjust Cam 4

1. The FOURTH cam is Cam 4, the CCW auxiliary switch adjustment. Drive the actuator to its CCW position. Then use a 2.5mm hex key to free up the cam set screw. Once it is free, rotate the hex key to the LEFT 10-15 degrees to reset the switch roller arm. Then snug the set screw up against the camshaft (CW) until slight pressure is felt. Then SLOWLY rotate the hex key to the RIGHT until you hear the “click” on the fourth switch. Continue to rotate the cam between 3 and 5 degrees to the RIGHT to make sure the auxiliary cam switch changes state before the actuator reaches its end of travel electrically. Tighten the cam set screw.

Mechanical Data

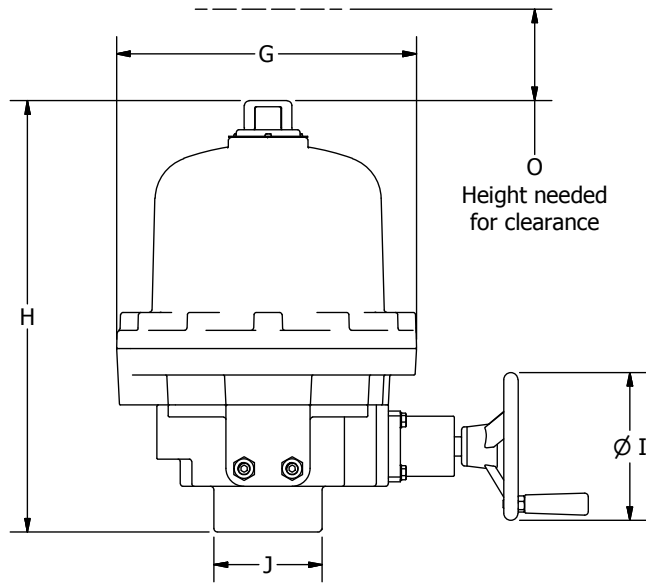
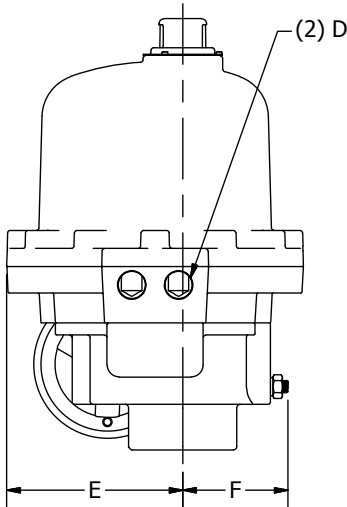
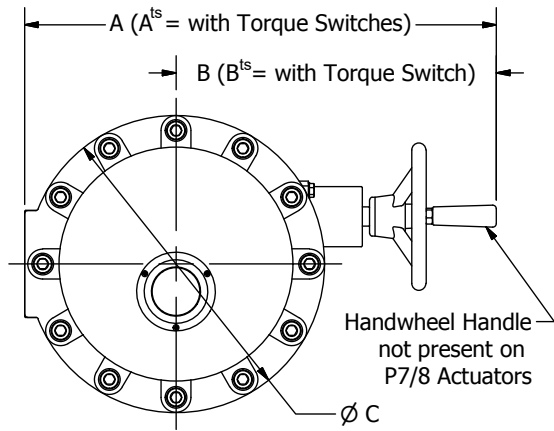
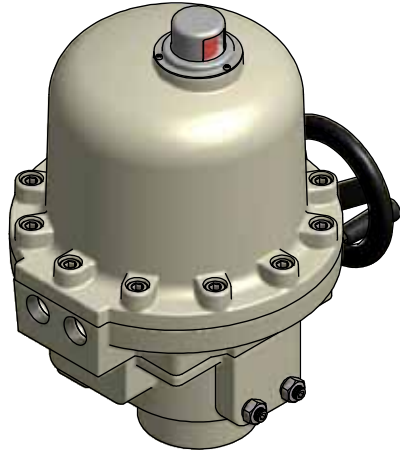

Drive Coupling Fabrication Data

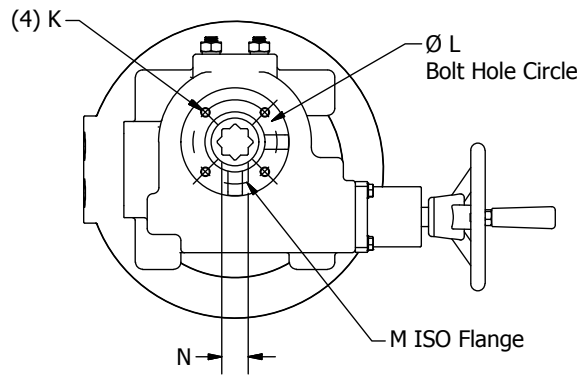
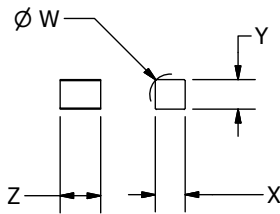

Dimensional Data P2~8-N7 Series Actuators: inches (mm)

	A	A ^{ts}	B	B ^{ts}	C	D	E	F	G	H	I
P2~P3	14.0 (355)	15.5 (392)	9.0 (229)	10.5 (267)	9.7 (247)	3/4" NPT	5.8 (146)	3.4 (88)	9.8 (249)	14.1 (359)	4.8 (123)
P4~P6	16.7 (423)	19.2 (488)	10.8 (275)	13.4 (340)	11.2 (285)	3/4" NPT	7.3 (184)	5.0 (126)	11.5 (291)	15.3 (389)	7.6 (194)
P7~P8	14.9 (377)	18.4 (468)	9.0 (226)	12.6 (320)	11.2 (285)	3/4" NPT	9.3 (236)	5.0 (126)	11.5 (291)	18.8 (478)	11.6 (295)
	J	K	L	M	N	O	W	X	Y	Z	
P2~P3	3.5 (90)	M8 - 1.25 x 0.8" D	2.8 (70)	F07	.866 (22.0)	8.0 (203)	1.18 (30.0)	.866 (22.0)	.866 (22.0)	1.18 (30.0)	
P4~P6	4.9 (125)	M10-1.50 x 0.8" D	4.0 (102)	F10	1.378 (35.0)	8.0 (203)	1.89 (48.0)	1.378 (35.0)	1.378 (35.0)	1.58 (40.0)	
P7~P8	7.1 (180)	M12-1.75 x 1.0" D	4.9 (125)	F14	1.417 (36.0)	8.0 (203)	1.93 (49.0)	1.417 (36.0)	1.417 (36.0)	1.77 (45.0)	

Dim X and Y Tolerance: +0.000" -0.005" (+0.00mm -0.13mm)

FM_P28 HV-PN7 (-TS) Ver. J_073119



Mechanical Data



P Series Exploded View

(P2/3-120N7 unit is shown)

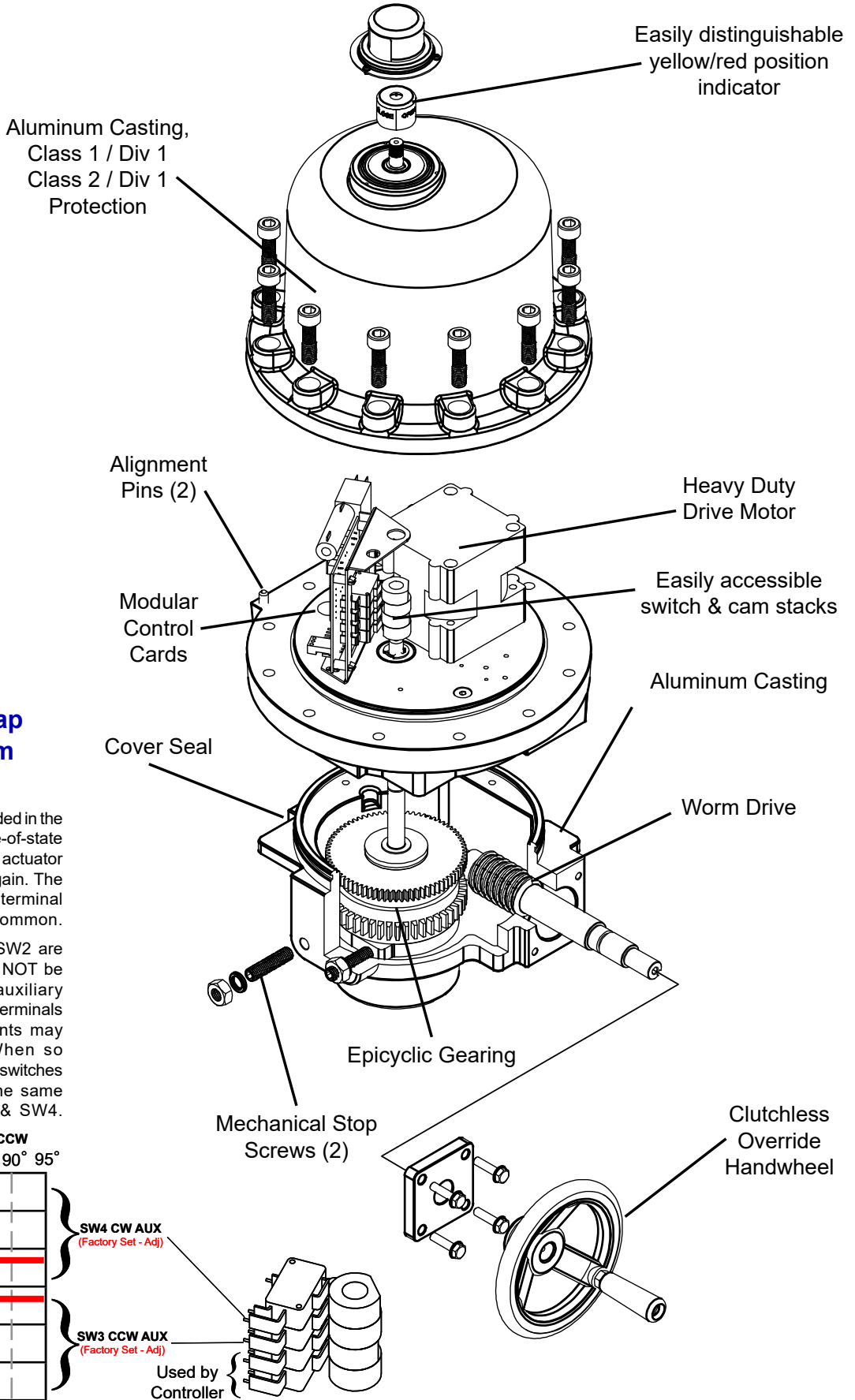

Switch Logic Map and Switch/Cam Arrangement

Switch sequencing data is provided in the table below to show the change-of-state points during the rotation of the actuator from CCW to CW and back again. The red bars indicate when that terminal makes with it's respective common.

Limit switches for SW1 and SW2 are set at the factory and should NOT be changed. The INCLUDED auxiliary switches SW3 & SW4 are for terminals 7 thru 12 and those set points may be modified if need be. When so optioned, SW5 & SW6 auxiliary switches are initially set to function the same as auxiliary switches SW3 & SW4.

Terminal ID#	CW			CCW		
	-5°	0°	5°	85°	90°	95°
12	Not Open					
11	Open Common					
10	Open					
9	Not Closed					
8	Closed Common					
7	Closed					

SW4 CW AUX (Factory Set - Adj)
 SW3 CCW AUX (Factory Set - Adj)
 Used by Controller

FM_P28 HV PN7 (-TS) Ver J_073119



Commissioning for non TS units

After completing all mounting and wiring procedures and main power is available, it is now possible to commission the actuator.

1. Utilize the handwheel to rotate the actuator and damper, valve or other connected device through its full travel from fully CW to fully CCW and back again to check for any possible interference.
 - Do NOT utilize any mechanical advantage devices to rotate the handwheel (pipes, wrenches, extension bars, etc.).
2. Manually position the actuator to its mid-stroke position.
3. Make certain the 3 wire plug is fully seated on the 3-pin receptacle on the switch board.
4. Apply correct power to the unit.
 - 4.A Measure correct power on terminals 1 (Hot / L1) & 2 (Neu / L2) on the switch board.
 - 4.B Measure correct power on the two heater terminals on the switch board.
5. Command the field device to generate a CCW signal. The actuator rotates in a CCW direction (as viewed from above).
 - Measure terminals 2 and 6 for correct voltage (matching that measured in step 4.A).
 - Actuator will stop when it reaches it's fully CCW position.
6. Command the field device to generate a CW signal. The actuator rotates in a CW direction (as viewed from above).
 - Measure terminals 2 and 4 for correct voltage (matching that measured in step 4.A).
 - Actuator will stop when it reaches it's fully CW position.
7. Actuator is now commissioned and operational.