



PROMATION ENGINEERING

Precision Actuation for Industry

Installation & Operation Manual



This product is certified for use in the following hazardous locations:

Class I, Division 1, Groups C, D
Class II, Division 1, Groups E, F, and G
Class III; T6 (85 °C)

Ex d IIB Gb T6; Ex tb IIIC T85°C Db
Class I, Zone 1, AEx d IIB Gb T6
Zone 21, AEx tb IIIC T85°C Db

and requires procedures and equipment rated for installation in those areas.



This IOM is for the following
ProMation Engineering Products:

P2-120PN7-HR

P2-230PN7-HR

P2-120PN7-HR-TS

P2-230PN7-HR-TS

P3-120PN7-HR

P3-230PN7-HR

P3-120PN7-HR-TS

P3-230PN7-HR-TS

Product mounting, set up, and installation notes specific to Hazardous Location Actuators.

Operation and maintenance of a hazardous location actuator is the same as for an ordinary location actuator with the following amendments:

1. ONLY install a hazardous location actuator in a hazardous location for which the actuator was designed. The actuator is clearly marked with the classification for which it was designed and tested.
2. Mount, calibrate, and test actuators only during non-hazardous conditions.
3. Do NOT operate in ambient temperatures above +125° F (+52° C).
4. Do NOT, under any circumstances, remove the cover of the actuator while in a hazardous location with power still present inside the actuator. This could cause ignition of a hazardous atmosphere.
5. After removal of the cover care must be taken not to scratch, chip, or deform the mating surfaces of the cover and base of the actuator (see photos at right). Deformation to these surfaces negates the hazardous location rating of this actuator and the actuator should be removed from hazardous location service.
6. Mating surfaces of the cover and base must be cleaned before replacing cover. When replacing the actuator cover, carefully align the two pins (non-removable) embedded in the lower housing with the corresponding holes in the top housing. Fully seat the cover before tightening the cover bolts to avoid damaging the cover.
7. After securing the cover back onto the actuator there should be NO gaps larger than 0.003 in. (0.08mm) between the cover and the base of the actuator. This can be checked by a 0.003 in. thick by 1/2 in. wide feeler gauge which may not enter between the two faces more than 1/8 of an inch.
8. All electrical connections must be to national, state, and local codes and in accordance with hazardous location specifications for which this actuator is to be used.
9. Reducers, glands, and/or conduit must be appropriately certified to be used in hazardous locations.
10. To reduce the risk of ignition of hazardous atmospheres, an appropriately certified sealing fitting, cable gland or plug must be directly connected to the enclosure.
11. An unused conduit port must be sealed with an appropriately certified threaded blanking plug.
12. Under certain extreme circumstances, the non-metallic parts incorporated in the enclosure of this equipment may generate an ignition-capable level of electrostatic charge. Therefore the equipment shall not be installed in a location where the external conditions are conducive to the build-up of electrostatic charge on such surfaces. In addition, the equipment shall only be cleaned with a damp cloth.

Class I, Division 1, Groups C, D
Class II, Division 1, Groups E, F, G
Class III; T6

Ex d IIB Gb T6; Ex tb IIIC T85°C Db
Class I, Zone 1, AEx d IIB Gb T6
Zone 21, AEx tb IIIC T85°C Db

CAUTION: To reduce the risk of ignition of hazardous atmospheres, disconnect the equipment from the supply circuit before opening. Keep assembly tightly closed when in operation. **WARNING:** To reduce the risk of ignition of hazardous atmospheres, an appropriately certified sealing fitting, cable gland or plug must be directly connected to the enclosure.

ATTENTION! Pour réduire le risque d'inflammation des atmosphères dangereuses, démontez l'équipement du circuit d'alimentation avant de l'ouvrir. Maintenez l'assemblage bien fermé lors de l'utilisation. **MIS EN GARDE!** Pour réduire le risque d'inflammation des atmosphères dangereuses, un joint d'étanchéité, un presse-étoupe ou une prise dûment certifié doit être lié à l'encastrement.

Plate found on actuator



Alignment pins/holes (refer to note 6) Mating Surfaces (refer to note 5, 6)



Feeler Gauge (refer to note 7)

FM_P213 ISO HV-PN4-HR (-TS) N7_Ver P. 100522

Field Manual

P2/3 HV-PN7-HR (-TS)

High Resolution Proportional Control w/ Feedback

ISO5211 F07 8P22



Actuator Sizes and Voltage Options

	Product Family	Torque Output		Voltage Options				
		in lbs	Nm	12DC	24DC	24AC	120AC	230AC
Actuators In This IOM	P2	800	90	✓	✓	✓	✓	✓
	P3	1,335	150	✓	✓	✓	✓	✓
	P4	3,500	400	✓	✓	✓	✓	✓
	P5	4,400	500	✓	✓	✓	✓	✓
	P6	5,750	650	✓	✓	✓	✓	✓
	P7	8,900	1,000		✓	✓	✓	✓
	P8	13,250	1,500		✓	✓	✓	✓
	P9	17,500	2,000				✓	✓
	P10	22,000	2,500				✓	✓
	P11	26,500	3,000				✓	✓
	P12	31,000	3,500				✓	✓
	P13	40,000	4,500				✓	✓

FM_P213 ISO HV-PN4-HR (-TS) NZ_Ver P 100522

Product Specifications

These may be equipped with internal torque switches (-TS) which protect the gear train, motor and controlled equipment from damage when high torque conditions exist.

These protective devices are NOT adjustable. More information on this technology is found throughout this manual.

Actuator Specifications	P2		P3	
	800”lbs/90Nm		1335”lbs/150Nm	
Torque “lb/Nm				
Supply Voltage	120vac	230vac	120vac	230vac
Max Inrush Current	1.8A	0.8A	1.8A	1.2A
Running Current	1.0A	0.5A	1.2A	1.0A
Motor	DC Brush Type			
Runtime (90°@60Hz/vdc)	15 sec		22 sec	
Runtime (90°@50Hz)	17 sec		26 sec	
Duty Cycle	75%			
Motor Starts	1200 per hour			
Weight	26lbs/12kg			
Mechanical Connections	ISO5211 F07 8pt 22mm			
Electrical Entry	(2) 3/4” NPT			
Electrical Terminations	12-16ga			
Environmental Rating	NEMA 4/4X			
Manual Override	5” Handwheel			
Control	On/Off/Jog			
Actuator Case Material	Aluminum Alloy, Powder coated			
Motor Protection	230°F/110°C Thermal F* Class *Totally Enclosed Non-Ventilated Motors			
Ambient Temperature	-22°F to +125°F			
Operating Range	-30°C to +52°C			

Introduction

This document provides necessary information for set-up, calibration, testing and use of the P Series quarter-turn electric actuators stated on the cover page. Each unit is shipped from the factory with initial calibration of mechanical stops, cams and switches completed for 0-90 degree operation. However, these are general settings and serve as a starting point for proper calibration of the actuator in its real-world application.

Safety

Safety is a basic factor any time you maintain and operate mechanical equipment. Appropriate handling methods and proper use of tools and personal protective equipment (PPE) can help prevent serious accidents which can cause injuries to you or a fellow worker. This manual was created to enable a trained user to install, adjust and troubleshoot your ProMation actuator.

Only competent and trained personnel should install, maintain and operate ProMation actuators. Any work related to this actuator must be carried out in accordance with this manual and related codes and regulations. Local workplace health and safety rules must always be followed.

Duty cycle

Duty cycle is the percent of time that an actuator spends running as a fraction of the total time. Duty Cycle is directly related to heat; excessively repositioning an actuator typically results in motor overheating which can cause permanent damage and/or reduced service life.

Duty cycle can be calculated as follows:

(example P2 series actuator running 3 seconds ON and 30 seconds OFF)

Runtime = 3s, Total time = 3s + 30s = 33s, therefore this duty cycle would be 9% (3/33)

Additionally, ProMation P series actuators are designed for a maximum of 1200 starts per hour (one start every 3 seconds maximum).

Shipping and Handling

1. This actuator is shipped in the FULLY CW position (2 color position indicator shows "CLOSE" and the Reference Dimple aligns with "0"). (The "1" mark is the FULLY CCW position).

2. **CONDUIT DEVICES MUST COMPLY WITH ALL APPLICABLE ELECTRICAL CODES FOR HAZARDOUS LOCATIONS.**

LES DISPOSITIFS DE CONDUIT DOIVENT ÊTRE CONFORMÉS DE TOUS LES CODES ÉLECTRIQUES APPLICABLES POUR LOCATIONS DANGEREUSES.

3. **Storage:** This unit should NOT be stored outside unless it is powered up and has proper conduit terminations. When NOT powered up, it should be stored in a clean, dry environment at all times.

4. This actuator has been **factory calibrated to operate between 0 degrees and 90 degrees. Most quarter-turn products will not require recalibration of these settings.** Check alignment of actuator and driven device. If any travel adjustment is necessary, please refer to pages 7-9 for instructions.

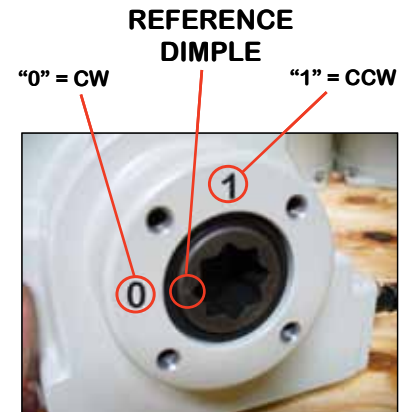

0 and 1 colored for clarity

Product Mounting and Setup

1. Fully CLOSE the valve or damper to which the actuator is to be mounted.
 - Keep in mind this actuator rotates CW (as viewed from above the unit) when driving CLOSED.
2. Assemble necessary linkage components and attach the actuator to the driven device.
3. Tighten mounting bolts, making sure actuator is centered on the device drive shaft.
4. Utilize the handwheel to check for unobstructed manual operation from fully CCW to fully CW positions BEFORE applying power to the unit.
5. Torque Switches (2), if so equipped, are factory set and **are NOT adjustable.**
6. Make the electrical connections per wiring diagram on page 5 or 6 depending on your model.
 - Connect POWER AND CONTROL to terminals marked 1, 2, 4, and 6.
 - Terminals 7-12 on the switch card (430-10100) are for the (adjustable) aux switches. They are dry type Form C rated 10A @ 250vac MAX.
7. Follow all rules and regulations for installing electrical equipment per applicable electrical code.
8. Do NOT apply power at this time.

Installation Notes

- These actuators are designed to be used between a horizontal and upright position. Do NOT mount the assembly with the actuator top below a horizontal position.
- When installing conduit, use proper techniques for entry into the actuator. Use drip loops to prevent conduit condensate from entering the actuator.
- Mechanical travel stops are factory calibrated for 90 degree operation. These stops are NOT designed to adjust mechanical rotation by more than +/- 3 degrees, they are for positioning the handwheel only.
- Both NPT conduit ports MUST use proper equipment to protect the rated integrity of the housing.
- The internal heater is to be used in ALL applications.
- Do NOT install the actuator outdoors or in humid environments unless it is powered up and the heater is functioning.
- Use proper wire size to prevent actuator failure (see chart on page 5 or 6 for proper wire sizing for your model).
- All terminals accept 12-16AWG solid/stranded wire.
- **Do NOT parallel wire multiple actuators together without utilizing isolation relays! Contact ProMation Engineering for a multiple actuator parallel wiring diagram.**
NE PAS mettre en parallèle des actionneurs multiples simultanément sans utiliser de relais d'isolement! Contactez ProMation Engineering pour un diagramme de câblage parallèle à plusieurs actionneurs.

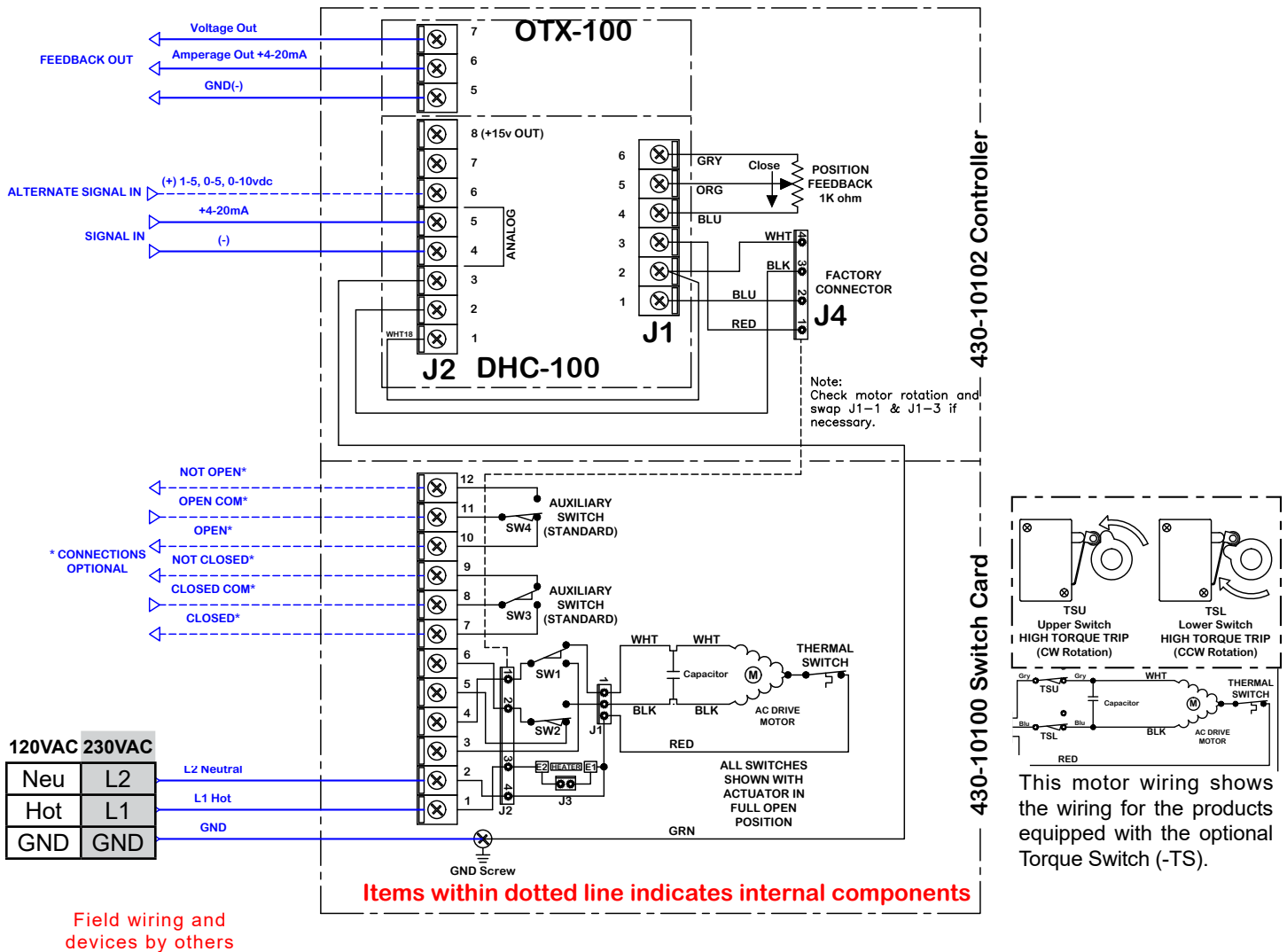

Torque Switches (if equipped)

For units equipped with torque switches: Torque switches provide mechanical overload protection for both the actuated device and the geartrain.

These are factory set and are not adjustable without proper equipment. Torque switches are set to limit actuator torque to approximately 105% of the actuator rated output.

The wiring diagram above shows the internal wiring connections between the control board, the torque switches and the motor. The upper torque switch controls loading in the CW direction, while the lower switch controls loading in the CCW direction.

Wire sizing data is provided in the table to assist in the selection of the proper wire size for ProMation actuators using various wire sizes over distance.

Please make sure to reference the correct voltage and do not exceed the indicated length of the wire run for each model.

Wire Sizing Chart

Actuator	MAX distance between Actuator and Supply (feet)			
	P2		P3	
	120VAC	230VAC	120VAC	230VAC
Voltage	120VAC	230VAC	120VAC	230VAC
Amps	1.8A	0.8A	1.8A	1.2A
Wire Gage	16	14	12	10
	722	1166	1783	3030
	3111	5026	7687	13068
	4523	7687	13068	19505
	2074	3351	5125	8712
	13003	19505	4523	13003



Diagram of Controller

Proportional Control

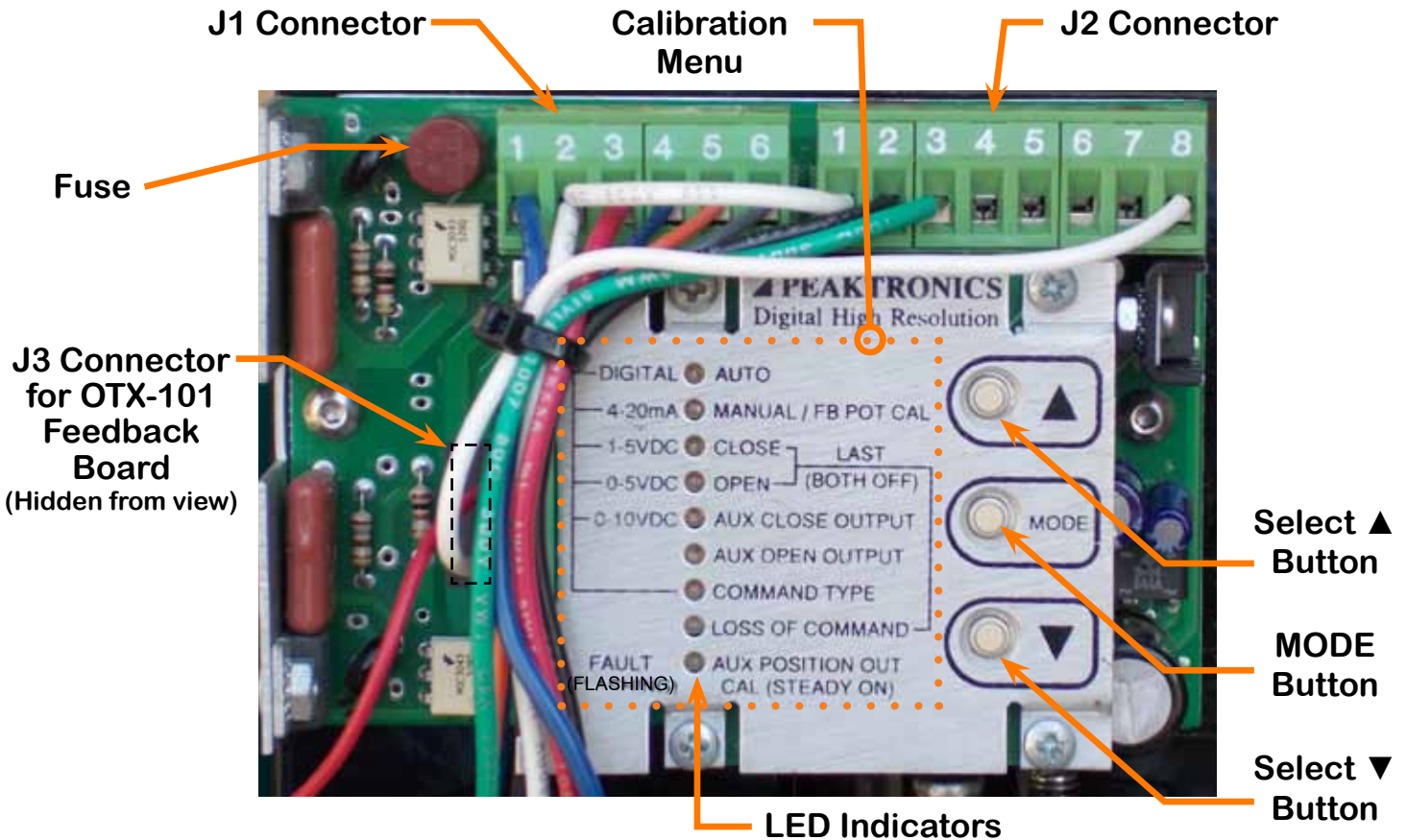

This proportional control card has been calibrated and tested at the factory to operate between 0 degrees and 90 degrees operating range. Controller position settings control the actuator, adjustment of cam settings may affect controller operation, resulting in a fault.

The Default Settings of the controller are as follows:

- Input Signal: 4-20mA (may be changed)
- Output Signal: 4-20mA (cannot be changed)
- Signal Response: Direct Acting (open = CCW)
- Loss of Command: Fail in Position

Input Signal Options:

- 4-20mA (default)
- 1-5vdc, 0-5vdc, 0-10vdc (Wire as shown on page 4, J2, terminal 6 and select Command Type from Calibration Menu.)

Fault Detection:

- Fault Indicator will flash and motor outputs are turned off until all faults are corrected.
- All Faults show on the same LED
- See Fault Table for priority listing of faults

Controller Notes:

- Limit (Cam) Switches (SW1 and SW2) can cause a Motor Stall Fault if set too close to the 0° (CW) or 90° (CCW) positions.

Fault Type	Problem	Resolution
Loss of Command	Command Signal disconnected or out of range	Reconnect or recalibrate command signal
Feedback Potentiometer Fault	Feedback signal disconnected or out of range	Reconnect or recalibrate feedback potentiometer
Motor 1 Stall	No motor motion detected (direction 1)	<ul style="list-style-type: none"> • Torque Switch event / Investigate possible blockage • Check SW1 or SW2 (if it clicks it is likely the fault) • Check for motor wiring/operation • Reverse motor direction • Rotate manual handwheel approximately 2°.
Motor 2 Stall	No motor motion detected (direction 2)	
Double Stall	No motor motion detected (both directions)	

FM_P213 ISO HV/PN4-HR (-TS) NZ_Ver P 100522

Setting Limit Switches and Auxiliary Switches (Cams)

This actuator has been factory calibrated to operate between 0 degrees and 90 degrees. Proportional Controller positioning changes different from 0 and 90 degrees will likely involve also changing cam settings. If cam adjustments cause the controller board to show faults, you will need to reposition the cam further outside your range of travel. Back out the mechanical stops before making any cam setting change so the gear train does not strike a mechanical travel stop.

Serious Damage to the actuator will result if the motor is allowed to drive the gear train into the mechanical stop!! Be sure the mechanical stops are out before making adjustments.



CCW Mechanical Stop
OPEN, 90°, 20mA, Green Cams



CW Mechanical Stop
CLOSE, 0°, 4mA, Red Cams



Mechanical Stop
Adjustment Positions

The mechanical stop screws limit handwheel operation ONLY and are NOT to be used as an electrical travel limiting device.

Loosen Mechanical Stops

- BEFORE power is applied, use a 17mm wrench and a 5mm hex key to loosen the LEFT and RIGHT SIDE mechanical stops.
- Turn the stop screws 5-6 turns CCW to allow electrical cam stop adjustment to keep the internal stops from running into the mechanical stop screws.
- Leave the stop screws out until controller calibration is complete.



Cam 4
Cam 3
Cam 2
Cam 1

Understanding Cam Operation

- The lowest cam, Cam 1 controls SW1, a CW limit switch secondary to the controller board. It will interrupt power to the board and motor if it changes state and shows as a fault on the controller board.
- The second cam, Cam 2 controls SW2, a CCW limit switch secondary to the controller board. It will interrupt power to the board and motor if it changes state and shows as a fault on the controller board.
- The third cam, Cam 3 controls SW3, a CW (CLOSED) auxiliary switch connected to the optional outputs 7-9 of the 430-10100 Switch Card.
- The uppermost cam, Cam 4 controls SW4, a CCW (OPEN) auxiliary switch connected to the optional outputs 10-12 of the 430-10100 Switch Card.

Practical Cam Considerations

- SW1 and SW2 can be used as electrical limit switches. For proper function their cams must be set outside (or beyond) the CLOSE and OPEN positions of the proportional controller.
- SW1 and SW2 do not impact initial controller calibration unless their cams are set within controller travel limits.
- After changing any cam settings, test the actuator limits for proper functionality.

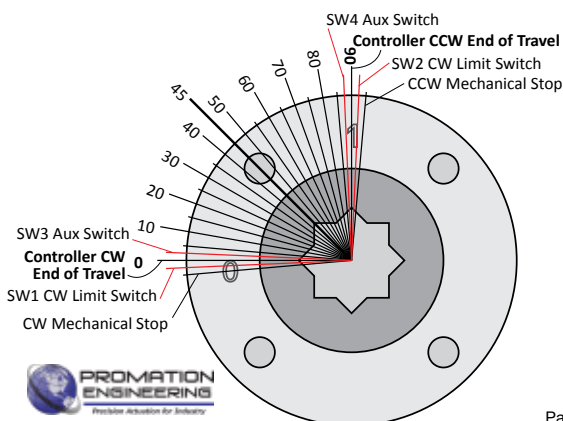

Cam Adjustments



Cam 1



Cam 2



Cam 3



Cam 4

Listed here for reference. **Mechanical stops must be out before changing cam settings. Proceed ONLY if adjustments are required.**

Adjust Cam 1 (SW1 -- CW limit switch)

1. The lowest cam is Cam 1, the CW limit switch (SW1) cam. Once the actuator is at its required CW position turn POWER OFF. Use the handwheel to drive more CW by 1-2°. Use a 2.5mm hex key to free up the cam set screw. Once it is free, rotate the hex key to the RIGHT 10-15 degrees to reset the switch roller arm. Then snug the set screw up against the camshaft (CW) until slight pressure is felt. Then SLOWLY rotate the hex key pushing the cam to the LEFT until you hear the “click” on the bottom switch indicating that correct adjustment has been achieved. Tighten the set screw.
2. Use the handwheel to check to be sure this is the correct CW position you require (refer to Page 6). Repeat step 1 if further adjustment is needed.

Adjust Cam 2 (SW2 -- CCW limit switch)

1. The second cam is Cam 2, the CCW limit switch (SW2) cam. Once the actuator is at its required CCW position turn POWER OFF. Use the handwheel to drive more CCW by 1-2°. Use a 2.5mm hex key to free up the cam set screw. Once it is free, rotate the hex key to the LEFT 10-15 degrees to reset the switch roller arm. Then snug the set screw up against the camshaft (CW) until slight pressure is felt. Then SLOWLY rotate the hex key pushing the cam to the RIGHT until you hear the “click” on the second switch indicating that correct adjustment has been achieved. Tighten the set screw.
2. Use the handwheel to check to be sure this is the correct CCW position you require (refer to Page 6). Repeat step 1 if further adjustment is needed.

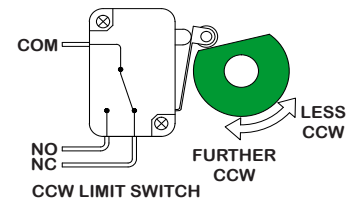
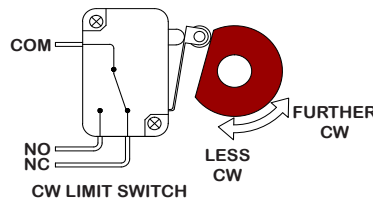

Adjust Cam 3 (SW3 -- CW auxiliary switch)

1. The THIRD cam is Cam 3, the CW auxiliary switch (SW3) cam. When the actuator is in its CW position set this cam. Use a 2.5mm hex key to free up the cam set screw. Once it is free, rotate the hex key to the RIGHT 10-15 degrees to reset the switch roller arm. Then snug the set screw up against the camshaft (CW) until slight pressure is felt. Then SLOWLY rotate the hex key and cam to the LEFT until you hear the “click” on the third switch. Continue to rotate the cam between 3 and 5 degrees to the LEFT to make sure the auxiliary cam switch changes state before the actuator reaches its end of travel electrically. Tighten the cam set screw.

Adjust Cam 4 (SW4 -- CCW auxiliary switch)

1. The FOURTH cam is Cam 4, the CCW auxiliary switch (SW4) cam. When the actuator is in its CCW position set this cam. Use a 2.5mm hex key to free up the cam set screw. Once it is free, rotate the hex key to the LEFT 10-15 degrees to reset the switch roller arm. Then snug the set screw up against the camshaft (CW) until slight pressure is felt. Then SLOWLY rotate the hex key to the RIGHT until you hear the “click” on the fourth switch. Continue to rotate the cam between 3 and 5 degrees to the RIGHT to make sure the auxiliary cam switch changes state before the actuator reaches its end of travel electrically. Tighten the cam set screw.

Pre Calibration Preparation

This procedure will assume that the actuator is installed correctly both mechanically and electrically with correct POWER and SIGNAL, the cams are factory set 1-2° beyond 0° and 90°, and the mechanical stop screws are out.

Calibration

This proportional control card has been calibrated and tested at the factory to operate between 0 degrees and 90 degrees operating range.

1. Test the travel of the actuator with the handwheel by rotating from 0° to 90° and listen/feel for the change of state of the limit switches. If Cams 1 and 2 are outside the desired range of travel, skip step 2.
2. Set cams per the **Setting Limit Switches and Auxiliary Switches (Cams)** section:
 - Cam 1 for approximately -1°.
 - Cam 3 for approximately 3°.
 - Cam 2 for approximately 91°.
 - Cam 4 cam for approximately 87°.

3A

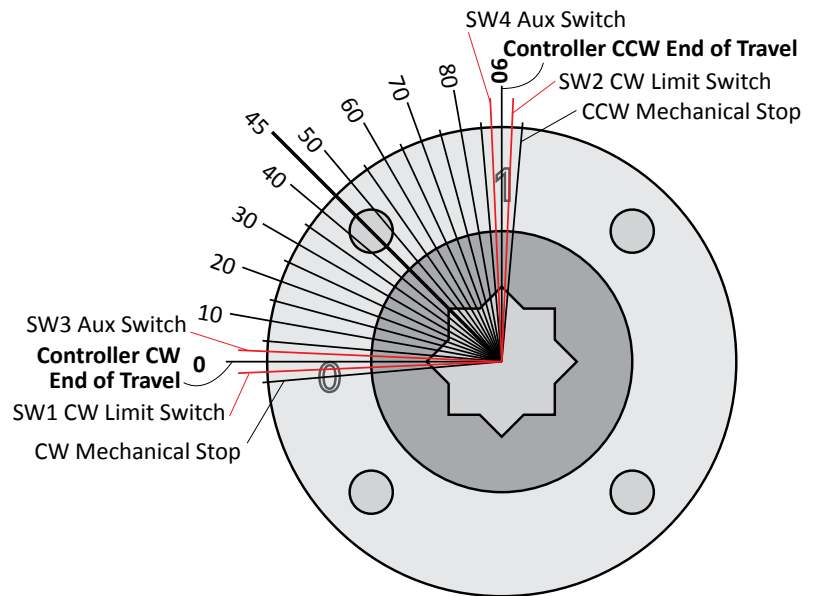
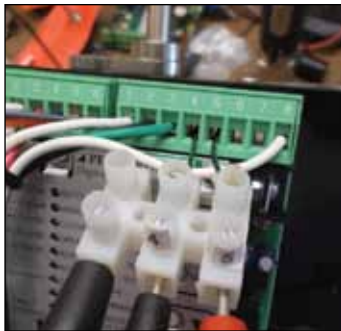

The open and close end of travel cams (Cam 1 and Cam 2) must be set outside the desired range of travel of the proportional card. If they trip, the proportional card stops the motor and reports a stall condition.

3. Connect Signal, Feedback and Power per wiring diagram:
 - 3.A Signal - (Optional) 4-20mA in uses Terminal 5 (+) and 4 (-) and 0-10V in uses Terminals 7 (+) and 5(-) on J2
 - 3.B Feedback - The OTX-100 is self powered. 4-20mA out uses Terminal 6 (+) and 5 (-). 0-10V out uses Terminals 7 (+) and 5(-). Use a known accurate meter to calibrate.
 - 3.C Power is connected to switchcard terminals marked 1 (hot) and 2 (neu).

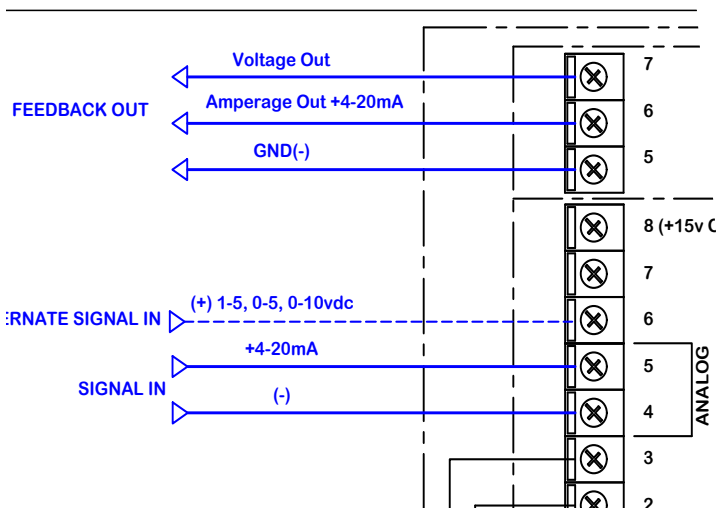

FM_P213 ISO HV-PN4-HR (-TS) N7_Ver P. 100522

Calibrating the proportional control board



4A

4. Apply line power.
 - 4.A The AUTO green LED will light.
 - 4.B The Red AUX POSITION OUT LED will blink if there is no control signal.

Calibration Interface Notes

The AUTO LED is lit during normal operation. Pressing MODE will enter the calibration sequence to change operational parameters. The MODE sequence goes in one direction. Each time MODE is pressed the current parameter is saved and the next one is presented. One can cycle through the operational parameters without changing them by pressing MODE repeatedly.

4B

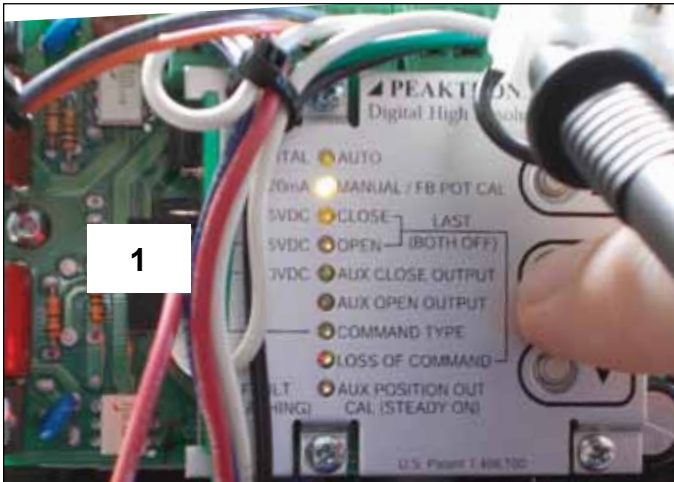
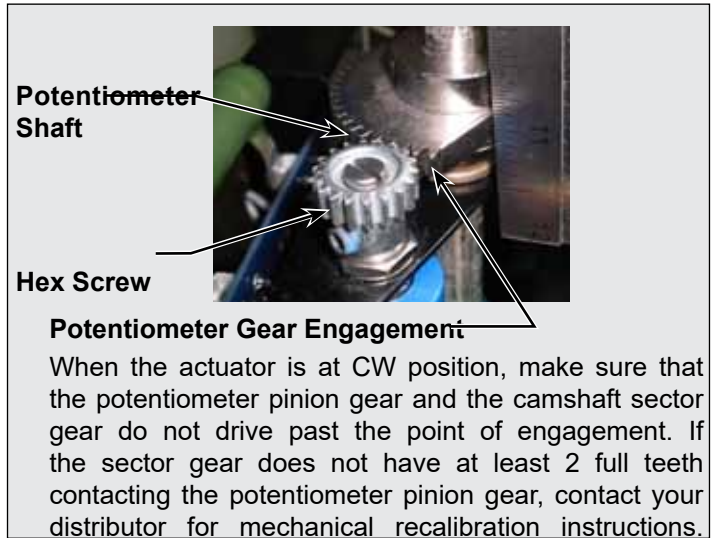
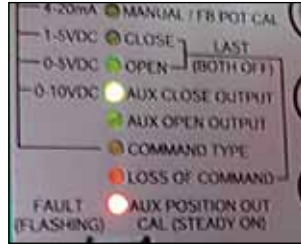

Begin Calibration

1. Press MODE until MANUAL/FB POT CAL LED is lit.
 - You may calibrate this as often as needed but it may affect the CW and CCW end positions if it changes.
2. Use ▲ and ▼ or handwheel to position the actuator to the mid position (i.e. 50% open or 12 mA).
 - Blinking amber MANUAL/FB POT CAL light means you need to adjust the potentiometer position.
3. **Feedback Potentiometer Calibration (FB POT CAL LED is blinking).**
 - 3.A Check Potentiometer Gear Engagement as shown.
 - 3.B Loosen the potentiometer shaft hex screw. Use a screwdriver to adjust the potentiometer shaft until the amber LED is steady.

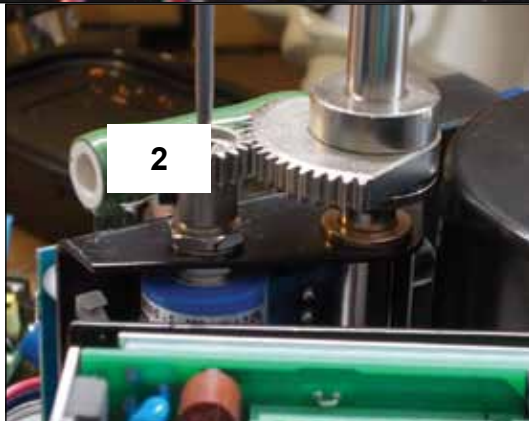

NOTE: The amber LED blinks more rapidly as you approach the proper mid position. The farther from that position, the slower the blinkrate.

Calibrating the proportional control board (continued)



4. **Set Closed (CW) Position** (CLOSE LED is lit)
 - 4.A The motor will drive to approximately the 25% position.
 - 4.B Use the handwheel or the ▲ and ▼ to position the actuator in the desired CLOSE position (i.e. 4 mA). (You must touch either ▲ or ▼ before the handwheel responds).
 - 4.C Press MODE to confirm setting. This will also move you to the next user input setting.
 - 4.D This CLOSE position is now set.
 - 4.E If the AUX CLOSE OUTPUT LED is lit, ignore it
 - 4.F OPEN LED is lit.



5. **Set Open (CCW) Position** (OPEN LED is lit)
 - 5.A The motor will drive to approximately the 75% position.
 - 5.B Use the handwheel or the ▲ and ▼ to position the actuator in the desired OPEN position (i.e. 20 mA). (You must touch either ▲ or ▼ before the handwheel responds).
 - 5.C Press MODE to confirm setting. This will also move you to the next user input setting.
 - 5.D This OPEN position is now set.
 - 5.E If the AUX OPEN OUTPUT LED is lit, ignore it.
 - 5.F AUX CLOSE OUTPUT is lit.

The motor may drive an arbitrary position.

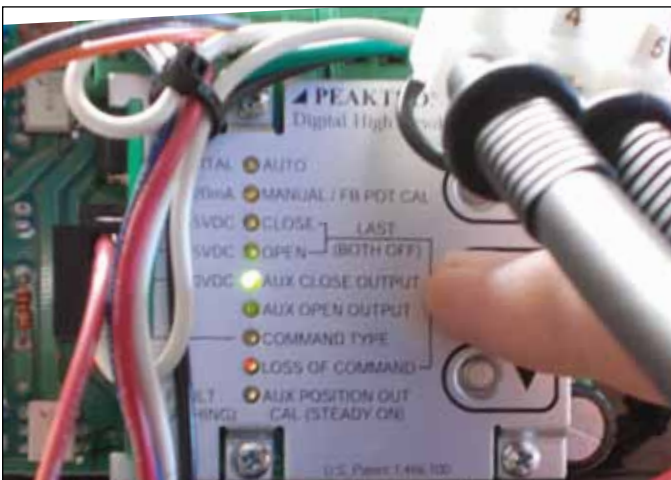

6. **Aux Close Output Settings** (AUX CLOSE OUTPUT is lit)
 - 6.A *This feature requires an additional optional board.*
 - 6.B Press MODE to skip.
 - 6.C AUX OPEN OUTPUT is lit.

The motor may drive an arbitrary position.

7. **Aux Open Output Settings** (AUX OPEN OUTPUT is lit)
 - 7.A *This feature requires an additional optional board.*
 - 7.B Press MODE.
 - 7.C COMMAND TYPE LED is lit.

Calibrating the proportional control board (continued)



8. Set Input Signal (COMMAND TYPE LED is lit)

8.A Use ▲ and ▼ to select the command signal type going into the DHC-100 board from the column left of the LEDs.

- 4-20mA (factory setting)
- 1-5VDC
- 0-5VDC
- 0-10VDC

8.B Press MODE.

8.C LOSS OF COMMAND LED is lit.

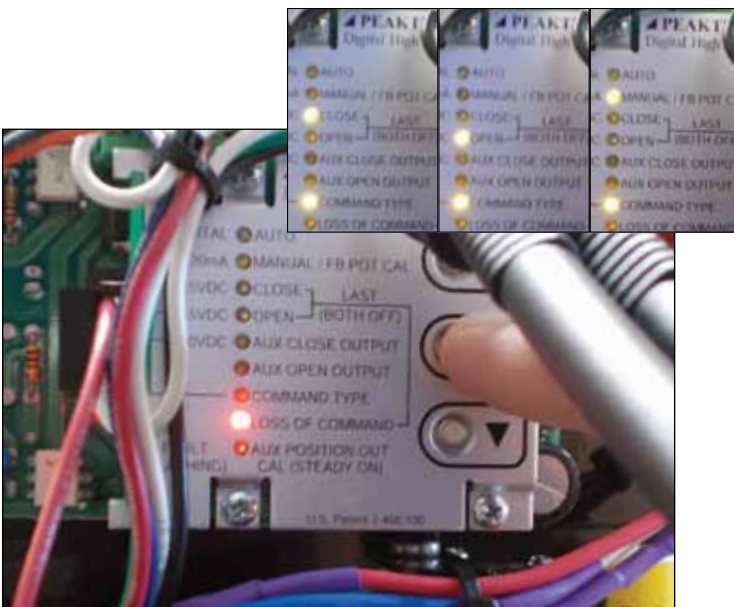

9. Set Loss of Signal (LOSS OF COMMAND LED is lit)

9.A Use ▲ and ▼ to select the fail position on loss of signal. Select from the column right of the LEDs.

- CLOSE - fails close (4mA)
- OPEN - fails open (20mA)
- (Both Off) - fails in place (default)

9.B Press MODE.

9.C AUX POSITION OUT CAL LED is lit.

The motor may drive an arbitrary position.



10. Trim the accuracy of the feedback (AUX POSITION OUT CAL LED is lit)

10.A The position of the actuator is unimportant for this step.

10.B CLOSE LED should be flashing

10.C Use ▲ and ▼ to adjust the mA feedback for the CLOSE position (i.e. 4.00mA). Read using a known accurate multimeter.

10.D Press MODE to confirm setting.

10.E OPEN LED should be flashing

10.F Use ▲ and ▼ to adjust the mA feedback for the OPEN position (i.e. 20.000mA). This is read on a known accurate multimeter.

10.G Press MODE to confirm setting, AUTO LED is lit.

Complete Calibration

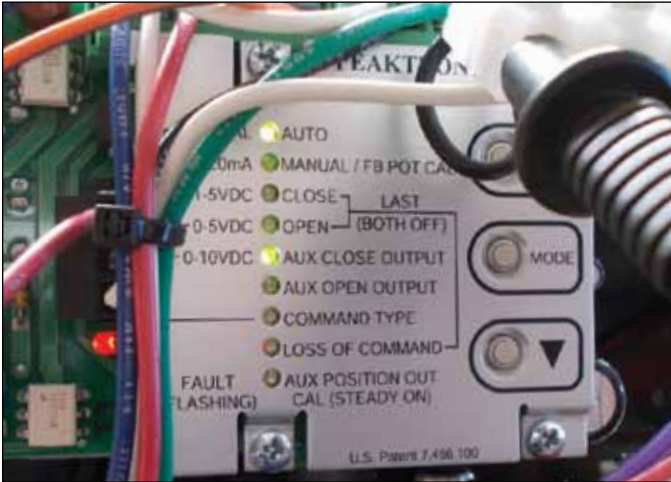

18. AUTO LED is lit. The actuator is now responding to the 4-20mA signal.

19. Calibration is complete.



20. Reinstall mechanical stop screws.

20.A CCW Stop - drive to the OPEN position and power down actuator.

- With handwheel, drive more open until you hear the SW2 switch make.
- Drive the handwheel 1/2 turn more OPEN.
- Use wrench and hex key to install the CCW Stop screw on the stop boss.
- With the handwheel, insure the end stop is approximately 1/2 handwheel turn after the SW2 switch makes.

20.B CW Stop - drive to the CLOSE position and power down actuator.

- With handwheel, drive more close until you hear the SW1 switch make.
- Drive the handwheel 1/2 turn more CLOSE.
- Use wrench and hex key to install the CW Stop screw on the stop boss. With the handwheel, insure the end stop is approximately 1/2 handwheel turn after the SW1 switch makes.



Confirm Controller End of Travel



1. Generate a 4mA control signal and drive the actuator to its fully CLOSED position.
 - 1.A Evaluate actuator position and feedback values.
 - 1.B If adjustments are needed, reenter the Calibration Menu.
 - 1.C If red AUX POSITION OUT LED is lit see step 4.
2. Generate a 20mA control signal and drive the actuator to its fully OPEN position.
 - 2.A Evaluate actuator position and feedback values.
 - 2.B If adjustments are needed, reenter the Calibration Menu.
 - 2.C If red AUX POSITION OUT LED is lit see step 4.
3. Any changes to the potentiometer will require you to recalibrate the actuator.
4. IF THE RED AUX POSITION OUT LED IS LIT:
 - 4.A First check the 4-20mA SIGNAL for power.
 - 4.B Next check to see if SW1 or SW2 are made. This indicates that a Switch is set inside the range 0-90°. They must be set outside that range by only 1-2° so as to not adversely affect calibration.
 - 4.C If you need to adjust cams you must review the 4mA and 20mA positions.

SPECIAL NOTES FOR IP-68 ENCLOSURES

Standard ProMation Actuator enclosures are certified to IP67, immersion in 1m water for 30 minutes

Optional **-68** actuator enclosures are certified to IP68, immersion in 7m water for 72 hours. Both per ANSI/IEC 60529 -Degrees of protection provided by enclosures.

Mechanical Data

P2/3 Series Dimensional Data

ISO 5211 Mount

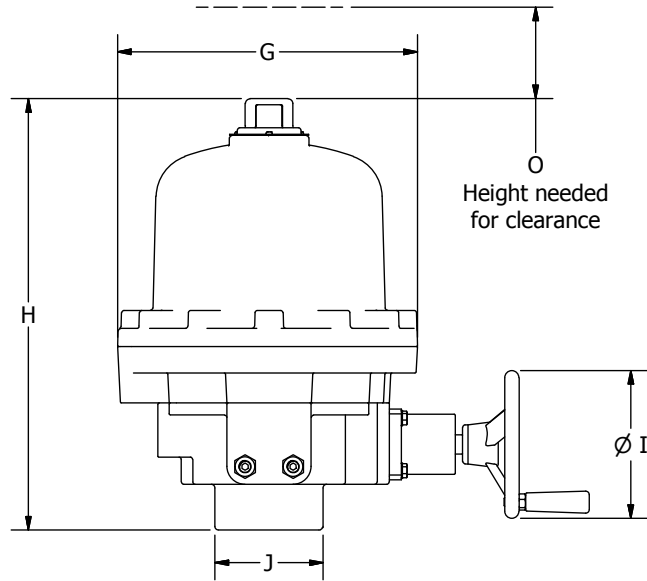
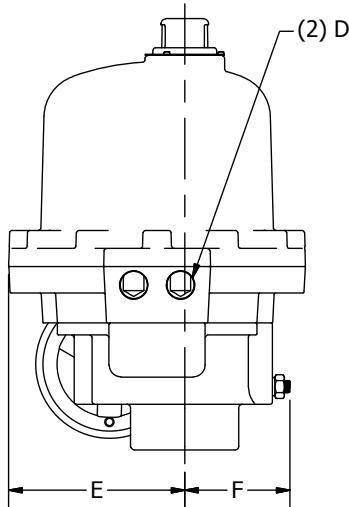
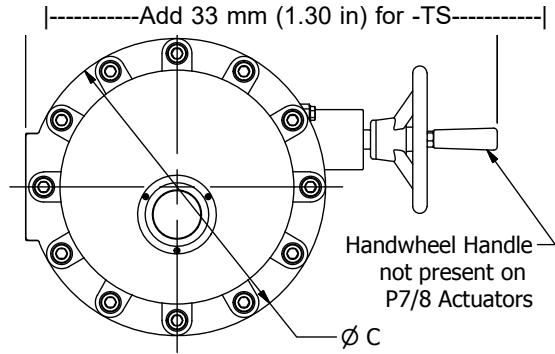
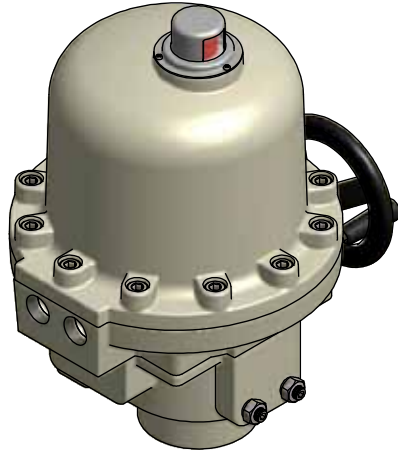

Drive Coupling Fabrication Data

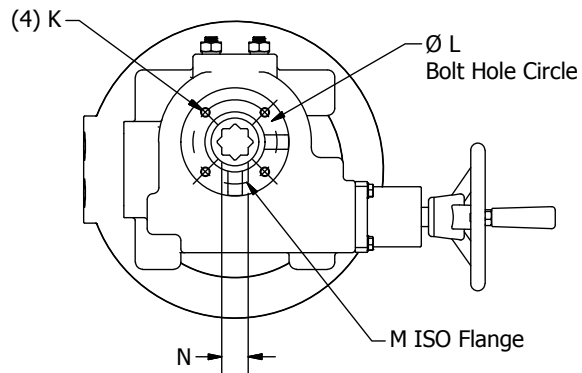
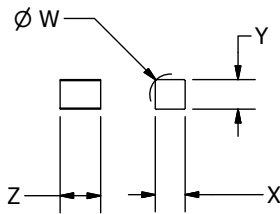

Dimensional Data P2~8-N7 Series Actuators: inches (mm)

	A	A ^{TS}	B	B ^{TS}	C	D	E	F	G	H	I
P2~P3	14.0 (355)	15.5 (392)	9.0 (229)	10.5 (267)	9.7 (247)	3/4" NPT	5.8 (146)	3.4 (88)	9.8 (249)	14.1 (359)	4.8 (123)
P4~P6	16.7 (423)	19.2 (488)	10.8 (275)	13.4 (340)	11.2 (285)	3/4" NPT	7.3 (184)	5.0 (126)	11.5 (291)	15.3 (389)	7.6 (194)
P7~P8	14.9 (377)	18.4 (468)	9.0 (226)	12.6 (320)	11.2 (285)	3/4" NPT	9.3 (236)	5.0 (126)	11.5 (291)	18.8 (478)	11.6 (295)
	J	K	L	M	N	O	W	X	Y	Z	
P2~P3	3.5 (90)	M8 - 1.25 x 0.8" D	2.8 (70)	F07	.866 (22.0)	8.0 (203)	1.18 (30.0)	.866 (22.0)	.866 (22.0)	1.18 (30.0)	
P4~P6	4.9 (125)	M10-1.50 x 0.8" D	4.0 (102)	F10	1.378 (35.0)	8.0 (203)	1.89 (48.0)	1.378 (35.0)	1.378 (35.0)	1.58 (40.0)	
P7~P8	7.1 (180)	M12-1.75 x 1.0" D	4.9 (125)	F14	1.417 (36.0)	8.0 (203)	1.93 (49.0)	1.417 (36.0)	1.417 (36.0)	1.77 (45.0)	

Dim X and Y Tolerance: +0.000" -0.005" (+0.00mm -0.13mm)

FM_P213 ISO HV-PN4-HR (-TS) N7_Ver P 100522

Mechanical Data



P Series Exploded View

(P2/3-120N7 unit is shown)

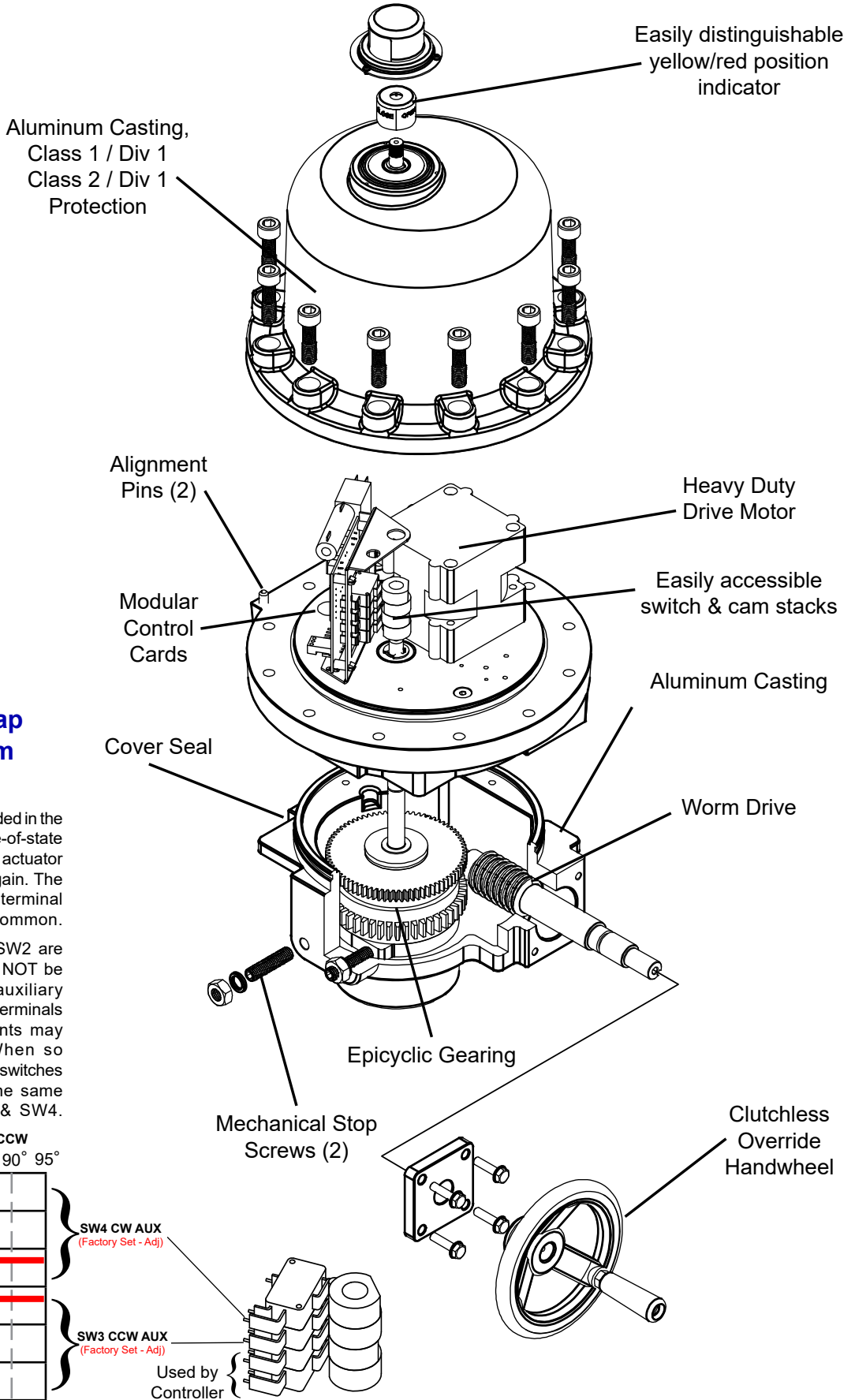

Switch Logic Map and Switch/Cam Arrangement

Switch sequencing data is provided in the table below to show the change-of-state points during the rotation of the actuator from CCW to CW and back again. The red bars indicate when that terminal makes with it's respective common.

Limit switches for SW1 and SW2 are set at the factory and should NOT be changed. The INCLUDED auxiliary switches SW3 & SW4 are for terminals 7 thru 12 and those set points may be modified if need be. When so optioned, SW5 & SW6 auxiliary switches are initially set to function the same as auxiliary switches SW3 & SW4.

Terminal ID#	CW			CCW		
	-5°	0°	5°	85°	90°	95°
12	Not Open					
11	Open Common					
10	Open					
9	Not Closed					
8	Closed Common					
7	Closed					

SW4 CW AUX (Factory Set - Adj)
 SW3 CCW AUX (Factory Set - Adj)
 Used by Controller

FM_P213 ISO HV/PN4+HR (-TS) NZ_Ver P. 100522

FM_P213 ISO HV/PN4+HR (-TS) NZ_Ver P. 100522



Commissioning

After completing all mounting and wiring procedures and main power is available, it is now possible to commission the actuator.

1. Utilize the handwheel to rotate the actuator and damper, valve or other connected device through its full travel from full CW to full CCW and back again to check for any possible interference. Do NOT utilize any mechanical advantage devices to rotate the handwheel (pipes, wrenches, extension bars, etc.).
2. Manually position the actuator to its mid-stroke position.
3. Make certain the 3 wire orange plug is fully seated on the 3-pin receptacle on the switch board.
4. Apply correct power to the unit.
5. Measure correct power on terminals 1 and 2 on the switch board.
6. Measure correct power on the two heater terminals on the switch board.
7. Command the field device to generate a CCW signal. The actuator rotates in a CCW direction (as viewed from above).
8. Actuator will stop when it reaches it's full CCW position.
9. Command the field device to generate a CW signal. The actuator rotates in a CW direction (as viewed from above).
10. Actuator will stop when it reaches it's full CW position.
11. Generate a mid-position signal at the field device to move the actuator off its full CW trip position.
12. Actuators with no -TS options are now commissioned and operational. See below for additional -TS steps.

Commissioning for TS units

TS units incorporate a torque overload protection system. In NORMAL operating mode, the torque switch drive cam is in this position:

WARNING! Do NOT adjust the torque switch cam settings. This will VOID the warranty.

High Torque Switch (top) for CW Output Drive Rotation
High Torque Switch (bottom) for CCW Output Drive Rotation

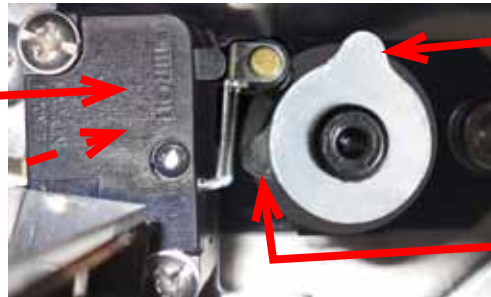

High Torque Cam (top) for CW Output Drive Rotation
High Torque Cam (bottom) for CCW Output Drive Rotation

Torque Switch cams shown in the NORMAL operating position (No high torque situations)

Testing Torque Switch Electrical Operation



Test Torque Switch functions

1. Generate a 4mA or 20mA control signal and let the actuator drive towards that CW or CCW position.
2. As the motor is running, simulate a torque switch event: Depress the top or bottom torque switch and hold it (one will immediately stop the motor).
3. Release the torque switch.
4. Test recovery from the torque switch event.
 - Move the handwheel 2° in either direction
 - Signal the motor to drive.
5. Repeat steps 1 through 4 in the opposite direction (20mA or 4mA) to test the opposing direction torque switch functionality.

Commissioning for TS units (continued)

Test Torque Switch CCW Mechanical Operation

1. Rotate the manual override handwheel in a CCW direction to continue to drive the output drive in a CCW direction until the drive system reaches the end of its MECHANICAL travel either by coming into contact with the mechanical stop screw OR it reaches the end of the valve (or damper) travel. This is indicative of an increasing force required to rotate the handwheel.
2. At this point the torque switch cam shaft starts to rotate in a CW direction. (There is no need to continue to rotate the handwheel further in the CCW direction, the torque switch cam shaft would continue to rotate in the CW direction until the LOWER cam trips the LOWER high torque switch).
3. At this point, stop rotating the handwheel as you've simulated reaching the electrical drive limit of the actuator under excessively high torque situations in the CCW output drive direction.

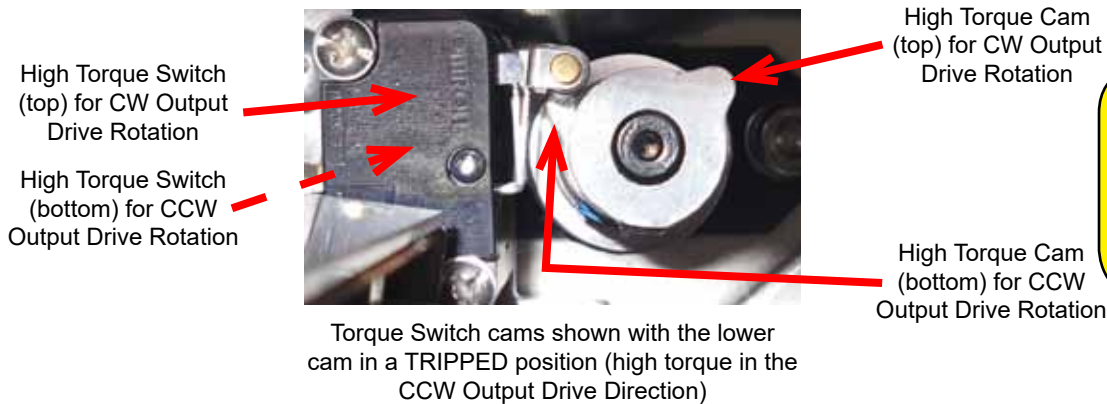

WARNING! Do NOT adjust the torque switch cam settings. This will VOID the warranty.

Test Torque Switch CW Mechanical Operation

1. Rotate the manual override handwheel in a CW direction to continue to drive the output drive in a CW direction until the drive system reaches the end of its MECHANICAL travel either by coming into contact with the mechanical stop screw OR it reaches the end of the valve (or damper) travel. This is indicative of an increasing force required to rotate the handwheel.
2. At this point the torque switch cam shaft starts to rotate in a CCW direction. (There is no need to continue to rotate the handwheel further in the CW direction, the torque switch cam shaft would continue to rotate in the CCW direction until the UPPER cam trips the UPPER high torque switch).
3. At this point, stop rotating the handwheel as you've simulated reaching the electrical drive limit of the actuator under excessively high torque situations in the CW output drive direction.

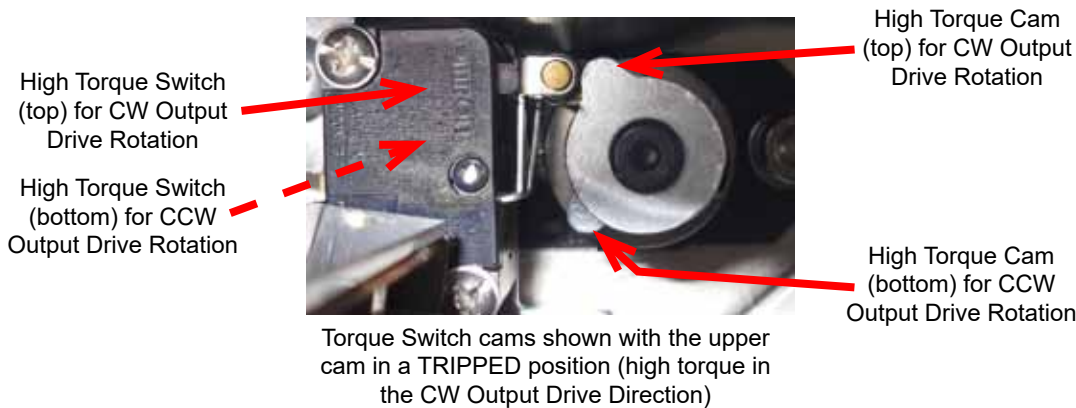

WARNING! Do NOT adjust the torque switch cam settings. This will VOID the warranty.

4. Generate a mid-position signal at the field device to move the actuator off its full CW trip position.
5. Actuator is now commissioned and operational.

