



**PROMATION
ENGINEERING**

Precision Actuation for Industry

Installation & Operation Manual

**This IOM is for the following
ProMation Engineering Products:**

PA-CCW-24A2S4

PA-CCW-24D2S4

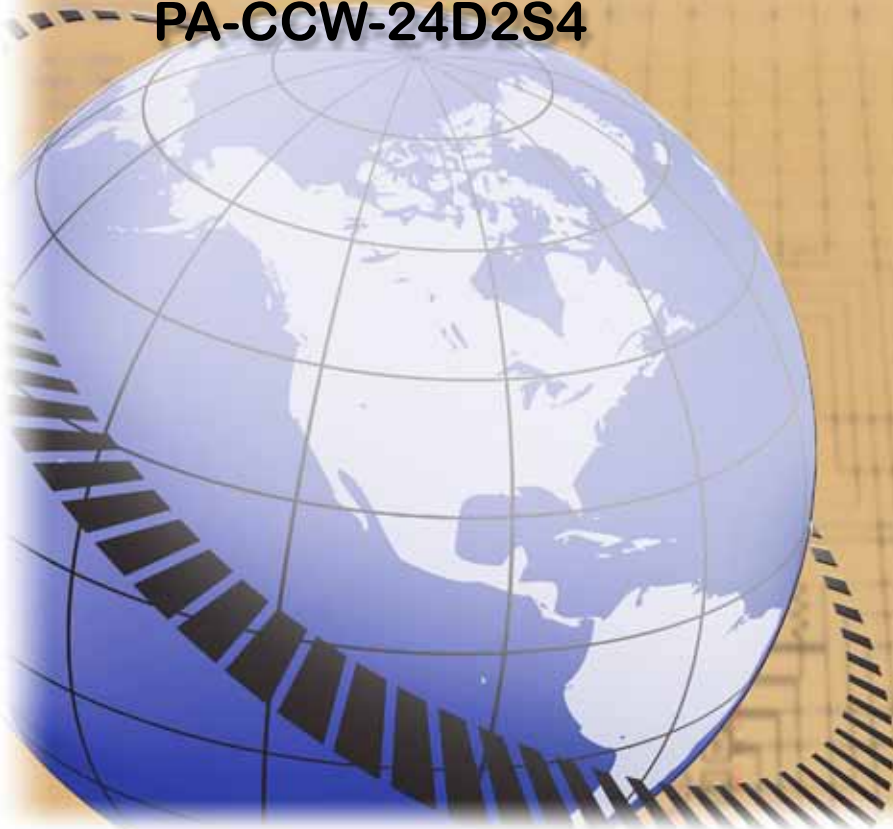

Spring Return Theory of Operation

From the Spring CCW position (UNLOADED), power is connected to terminals. While power is present, the actuator will respond to drive control signals depending on the model chosen.

- **A 2 position unit** will drive until it reaches its LOADED position (opposite the spring return direction).
- **A Proportional control unit** will follow an analog control signal for positioning and will HOLD until a modified control signal is received.
- **In each of these models** a motor brake unit is utilized to HOLD the actuator in position until commanded to move OR a loss of supply voltage.

If power is lost or removed at any time, the brake is released and the mechanical spring mechanism returns the actuator to its UNLOADED position. Once the spring mechanism has been released, the actuator will not drive under power again until:

- The unit has reached its UNLOADED position AND
- Power has been restored to the actuator AND
- Initial Power Startup delay of several seconds has elapsed.

If equipped with a manual override, while the actuator is UNLOADED the manual handwheel may be employed to position the actuator anywhere between the UNLOADED and LOADED position, and the actuator will HOLD in that position indefinitely, regardless of whether power is applied.

- The manual handwheel must return the actuator to its UNLOADED position BEFORE electrical operation of the actuator will be possible. ***This is a safety feature.***
- If the actuator has been driven electrically to its LOADED position, the manual handwheel cannot be used to drive the actuator back to its UNLOADED position. ***This safety feature*** prevents the unexpected release of stored spring energy.
- Remote indication of actuator status can be accomplished by utilizing built-in auxiliary switches. After power has been restored these dry-contact form C switches will show when an actuator has been overridden, indicating the actuator will NOT operate under control again until it has been manually returned to the UNLOADED position (explained above).



Location indicator shown in the UNLOADED operational position.

Wire sizing data is provided in the table to assist in the selection of the proper wire size for these actuators using various wire sizes over distance.

Please make sure to reference the correct voltage and do not exceed the indicated length of the wire run for each model.

Wire Sizing Chart

	MAX distance between Actuator and Supply (feet)	
Actuator/ Voltage	PAO 24VAC	PAO 24VDC
Wires Gage \ Amps	4.0A	4.0A
16	65	65
14	105	105
12	160	160
10	273	273
8	407	407



**PROMATION
ENGINEERING**

Precision Actuation for Industry

Field Manual
PA-CCW 24 2S4 Series
CCW Spring Return
ISO5211 F07 8P17



Table of Contents

- ii Spring Return Theory of Operation
- 2 Product Specifications
- 3 Shipping and Handling
- 3 Product Mounting and Setup
- 3 Installation Notes
- 4 Wiring Diagram
- 5 Product Mounting and Setup
- 5 Adjusting Mechanical End-Stop CCW Position (UNLOADED)
- 6 Adjusting Cam for CCW Position (UNLOADED)
- 6 Adjusting Cam for CW Position (LOADED)
- 7 Adjusting the actuator Auxiliary Switches
- 8 Mechanical Data
- 9 Mechanical Data
- 10 Commissioning
- 11 Troubleshooting

FM19_PAD CCW 24 2S4 Ver J 021423

Product Specifications

Actuator Specifications	PA	
Torque "lb/Nm	445"lbs/50Nm	
Supply Voltage	24vac	24vdc
Max Inrush Current	4.0A	4.0A
Running Current	3.0A	3.0A
Motor	DC Brush Type	
Runtime (90°)	7 sec	7 sec
Runtime (90°@50Hz)	--	--
Runtime (spring)	3 sec	3 sec
Duty Cycle	50%	
Motor Starts	300 per hour	
Weight	65 lbs / 30kg	
Mechanical Connections	ISO5211 F07 8pt 17mm	
Electrical Entry	(2) 3/4" NPT	
Electrical Terminations	12-16ga	
Environmental Rating	NEMA 4/4X	
Manual Override	None	
Control	On/Off	
Actuator Case material	Aluminum Alloy, Powder coated	
Motor Protection	230°F/110°C Thermal F* Class *Totally Enclosed Non-Ventilated Motors	
Ambient Temperature Operating Range	-22°F to +149°F -30°C to +65°C	

Introduction

This document provides necessary information for set-up, calibration, testing and use of the Spring Return Series of quarter-turn spring return electric actuators stated on the cover page. Each unit is shipped from the factory with initial calibration of mechanical stops, cams and switches completed for 0-90 degree operation. However, these are general settings and serve as a starting point for proper calibration of the actuator in its real-world application.

Safety

Safety is a basic factor any time you maintain and operate mechanical equipment. Appropriate handling methods and proper use of tools and clothes can help prevent serious accidents -- accidents which can cause injuries to you or a fellow worker. This manual was created to enable a trained user to install, adjust and troubleshoot your ProMation actuator.

Only competent and trained personnel should install, maintain and operate ProMation actuators. Any work related to this actuator must be carried out in accordance with this manual and related codes and regulations. Local workplace health and safety rules should always be followed.

Duty cycle

Duty cycle is the percent of time that an actuator spends running as a fraction of the total time. Duty Cycle is directly related to heat; excessively repositioning an actuator typically results in motor overheating which can cause permanent damage and/or reduced service life.

Duty cycle can be calculated as follows:

(example PA series actuator running 7 seconds ON and 70 seconds OFF)

Runtime = 7s, Total time = 7s + 70s = 77s, therefore this duty cycle would be 9% (7/77)

Additionally, ProMation PA~D series actuators are designed for a maximum of 300 starts per hour (one start every 12 seconds maximum).

Shipping and Handling

1. The actuator is shipped in the Spring CCW (UNLOADED) position.
2. **NOTE: This actuator is shipped with TEMPORARY PLUGS installed in BOTH EMT ports. These temporary plugs MUST be replaced with proper fittings appropriate for use in the environment to which the actuator is to be installed. Utilize DRIP LOOPS in the conduit connections to prevent condensate from entering the actuator. Power MUST be supplied to the unit immediately upon installation to keep the anti-condensate heater warm. FAILURE TO PROPERLY STORE ACTUATOR VOIDS WARRANTY**
3. **Storage:** This unit should NOT be stored outside unless it is powered up and has proper conduit terminations. When this unit is NOT powered up, it should be stored in a clean, dry environment at all times.
4. This actuator has been **factory calibrated to operate between 0 degrees and 90 degrees. Most quarter-turn products will not require recalibration of these settings.** To change calibration, refer to pages 5-7 for instructions.



The actuator is shipped from the factory in its fully CCW position. The top illustration shows "CLOSE" on a Red background for CCW. The reverse is "OPEN" on a Yellow background for CW.

The indicator may be removed and reinstalled if needed.

Product Mounting and Setup

1. Fully CLOSE the valve or damper to which the actuator is to be mounted.
 - Keep in mind this spring CCW actuator rotates CCW (as viewed from above the unit) when the unit springs closed (UNLOADED).
2. Assemble necessary linkage components and attach the actuator to the driven device.
3. Tighten mounting bolts, making sure actuator is centered on the device drive shaft.
4. Make the electrical connections per wiring diagram on page 4.
 - Connect POWER AND CONTROL to terminals marked 1, 3, and 7.
 - Terminals labelled A-F are for the (adjustable) aux switches. They are dry type Form C rated 10A @ 250vac MAX.
5. Do NOT apply power at this time.

Installation Notes

- These actuators are designed to be used between a horizontal and upright position. Do NOT mount the assembly with the actuator top below a horizontal position.
- When installing conduit, use proper techniques for entry into the actuator. Use drip loops to prevent conduit condensate from entering the actuator.
- The mechanical travel stop is factory calibrated for the Spring CCW (UNLOADED) position. The stop is NOT designed to adjust the Spring CCW (UNLOADED) position by more than +/- 3 degrees.
- There is no mechanical stop for the LOADED position, see page 5 for details.
- Both NPT conduit ports MUST use proper equipment to protect the NEMA 4X integrity of the housing.
- The internal heater is to be used in ALL applications.
- Do NOT install the actuator outdoors or in humid environments unless it is powered up and the heater is functioning.
- Use proper wire size to prevent actuator failure (see chart on page 4 for proper wire sizing).
- All terminals accept 12-16AWG solid/stranded wire.



Bottom view of actuator showing the 8 point drive shaft and the ISO 5211 mounting hole pattern.

Wiring Diagram

On/Off Control

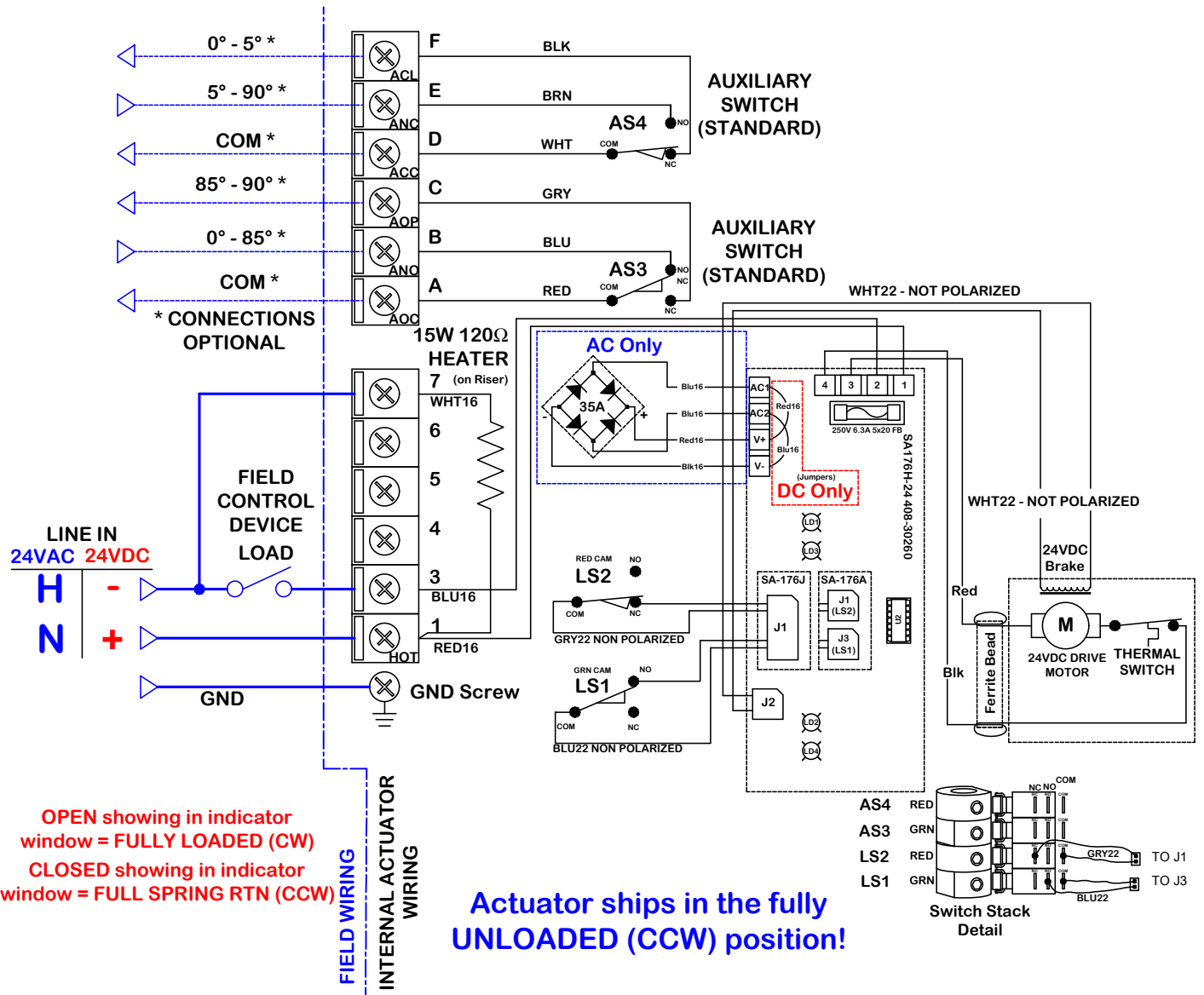

Wire sizing data is provided in the table to assist in the selection of the proper wire size for these actuators using various wire sizes over distance.

Please make sure to reference the correct voltage and do not exceed the indicated length of the wire run for each model.

Wire Sizing Chart

Actuator/ Voltage	MAX distance between Actuator and Supply (feet)	
	PA 24VAC	PA 24VDC
Amps	4.0A	4.0A
Wire Gage		
16	65	65
14	105	105
12	160	160
10	273	273
8	407	407

Product Mounting and Setup

This actuator has been factory calibrated to operate between 0 degrees and 90 degrees. Most quarter-turn products will not require recalibration of these settings. The following procedure is a reference for set-up, calibration, testing and use of the Spring Return quarter-turn electric actuators.

Do not make adjustments to this device until you have contacted the factory (+1 352-544-8436) for assistance. Damage to product as a result of incorrect cam and/or mechanical adjustments will VOID WARRANTY

1. Mount the actuator to the valve or damper to be actuated. Remember, the actuator is shipped in the spring return (UNLOADED) position. When viewed from ABOVE the actuator, the spring CCW units spring closed (UNLOADED) in a CCW direction. Make sure your valve or damper is in the CORRECT fail position before mounting the actuator to it.
2. Once the two components are bolted together, **apply power to the actuator**, HOT (7) and NEUTRAL (1) and generate a control signal to drive the actuator to the CW (LOADED) position. Then remove power to allow the spring return system to drive the device back to the fail position -- CCW (UNLOADED).

Adjusting Mechanical End-Stop CCW Position (UNLOADED)



Remove adjustment housing cover.
Refer to step 3

Remove Adjustment Housing Cover

3. If it is determined that the end-stop position is not correctly aligned, it will be necessary to ADJUST the mechanical END STOP. To do this, remove the adjustment housing cover using a 5mm hex key.



Loosen lock nut.
Refer to step 4

Loosen Lock Nut and Adjust End Stop

4. There will be an adjustment nut and a lock nut inside the housing. Loosen the lock nut using a 22mm hex wrench, and while holding the nut, use a 10mm open end wrench to turn the adjustment nut. (CW to move the end stop more towards the LOADED direction, or CCW to move the end stop further AWAY from the LOADED direction). Do NOT turn the adjustment nut more than 5 turns in either direction!



Turn the adjustment nut to adjust UNLOADED position.
Refer to step 4

Tighten Lock Nut and Reattach Adjustment Housing Cover

5. Tighten the 22mm lock nut to secure the adjustment.
6. Reattach the cover removed in step 3.

Adjusting Cam for CCW Position (UNLOADED)

Do NOT rotate the cams more than 3 degrees...Serious Damage to the actuator will result if the motor or handwheel is allowed to drive the gear train beyond the recommended spring compression!



Refer to steps 7-9

Adjust Cam 2

7. It will now be necessary to re-adjust the electrical travel cam to coincide with the new mechanical stop adjustment made in the steps above. With NO POWER APPLIED to the actuator, use a 2.5mm hex key to loosen the #2 (RED) cam set screw. Once it is free, rotate the hex key to the LEFT a few degrees to reset the switch roller arm. Then snug the set screw up against the camshaft (CW) until slight pressure is felt. Then SLOWLY rotate the hex key pushing the cam to the RIGHT until you hear the “click” on the second switch indicating that correct adjustment has been achieved. Tighten the cam set screw.

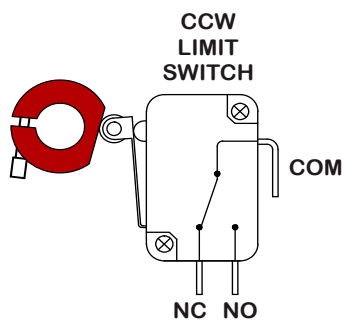

Note that this setting is only for “proof” that the unit has reached the full spring return position. **Adjusting this cam does not affect the spring return travel of the actuator.**

8. **NOTE: Incorrectly adjusted cams will prevent the actuator from running under power.**
9. Apply power and generate a control signal to drive the actuator approximately 20 degrees CW. Remove power to let the spring return system drive back to the new end adjustment. Check the setting and repeat from step 3 if necessary.

Adjusting Cam for CW Position (LOADED)

DO NOT attempt to adjust the CW end of travel unless it is absolutely necessary.



Refer to steps 11-12

10. Again apply power and generate a control signal to drive the actuator to the LOADED position. The actuator will stop and HOLD when it reaches it's end of travel.

DO NOT attempt to adjust the CW end of travel unless it is absolutely necessary. This can ONLY be done with power applied. If you remove power, the actuator will spring closed, making it impossible to make the adjustment. If you move the cam too far to the RIGHT, the motor will drive the geartrain beyond the full compression of the springs. ***This will DAMAGE the spring system. USE EXTREME CAUTION IF ADJUSTMENT IS NEEDED.***

Adjust Cam 1

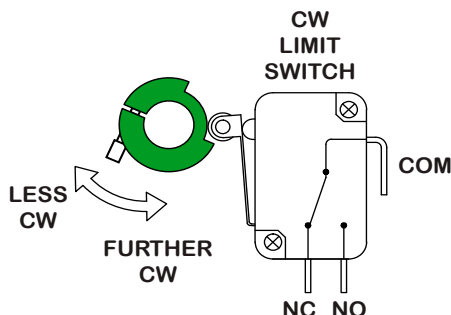

11. If the STOP point is incorrect, the #1 (GREEN) cam must be adjusted. Use a 2.5mm hex key to loosen the cam set screw. SLOWLY rotate the hex key pushing the cam to the RIGHT to drive FURTHER CW, or to the LEFT to drive LESS CW.
12. Tighten the cam set screw.

Adjusting the actuator Auxiliary Switches



Cam 4

Adjust Cam 4

1. The fourth (RED) cam is the CCW auxiliary switch adjustment. Spring return the actuator to its CCW position. Then use a 2.5mm hex key to free up the cam set screw. Once it is free, rotate the hex key to the LEFT a few degrees to reset the switch roller arm. Then snug the set screw up against the camshaft until slight pressure is felt. Then SLOWLY rotate the hex key and cam to the RIGHT until you hear the “click” on the fourth switch. Continue to rotate the cam between 3 and 5 degrees to the RIGHT to make sure the auxiliary cam switch changes state before the actuator reaches its end of travel electrically. Tighten the cam set screw.



Cam 3

Adjust Cam 3

1. The THIRD (GREEN) cam is the CW auxiliary switch adjustment. Drive the actuator to its CW position. Then use a 2.5mm hex key to free up the cam set screw. Once it is free, rotate the hex key to the RIGHT a few degrees to reset the switch roller arm. Then snug the set screw up against the camshaft until slight pressure is felt. Then SLOWLY rotate the hex key and cam to the LEFT until you hear the “click” on the third switch. Continue to rotate the cam between 3 and 5 degrees to the LEFT to make sure the auxiliary cam switch changes state before the actuator reaches its end of travel electrically. Tighten the cam set screw.

Failsafe and Handwheel Alignment



Check to insure that the top indicator matches the failsafe (unsprung) position of the flow control device it is being assembled to. Typically actuator will indicate the failsafe position is CLOSED. If the flow control device is fail OPEN, the top indicator must be rotated 90 degrees to agree with the failsafe OPEN position



The rotation indicator tag on the handwheel (if present) must match the rotation of the actuator to the CLOSE position of the flow control device. Check to insure Handwheel rotates in the proper direction for the flow control device.

If the rotation to the CLOSE position does not match the rotation needed to move to the CLOSE position, remove the indicator tag and reinstall to the correct rotation direction. The rotation to the CLOSE position may be against the spring direction.

PA indicators and handwheels shown for illustration purposes

Mechanical Data

PA CCW Series Dimensional Data

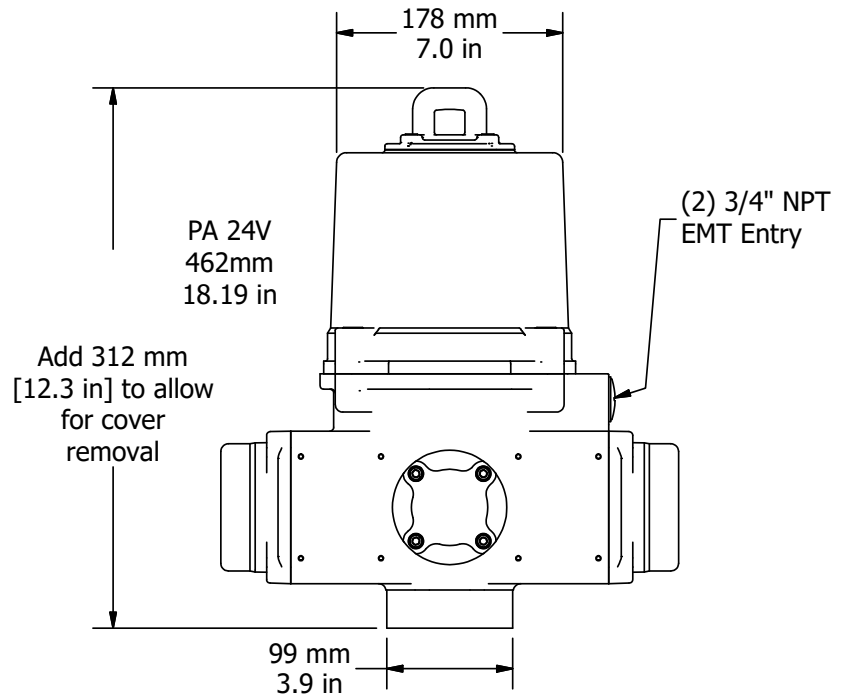
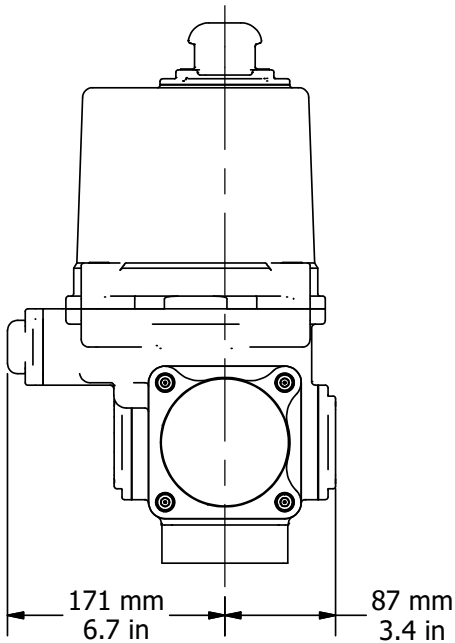
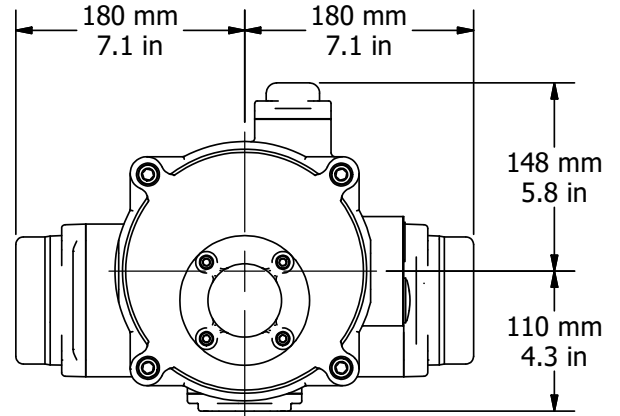
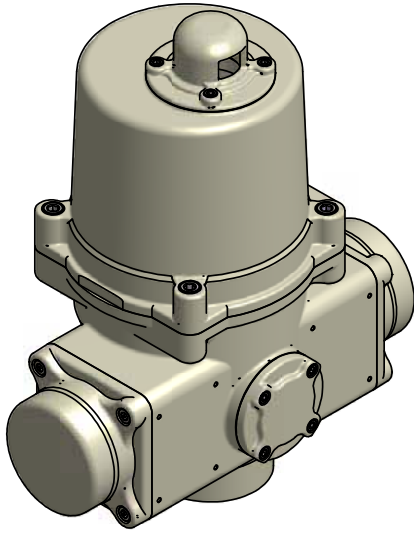

Drive Coupling Fabrication Data

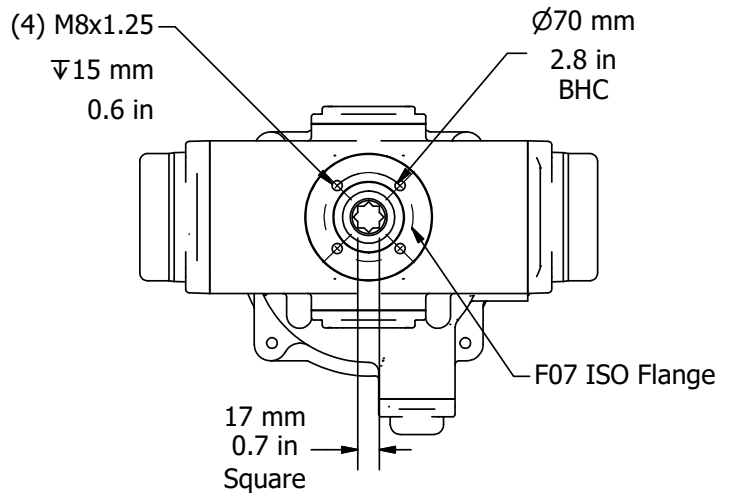
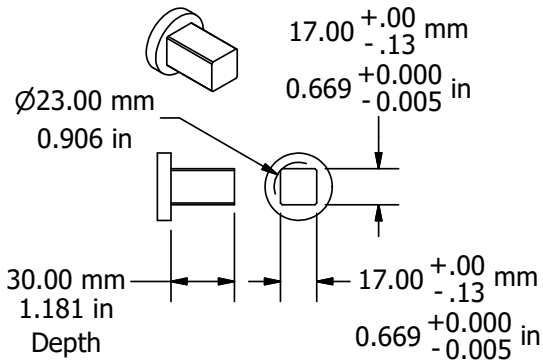

FM19_PAD CCW 24 2S4 Ver. J 021423

Mechanical Data

Spring Return Series Exploded View

(PA-CCW-1202S4 unit is shown)

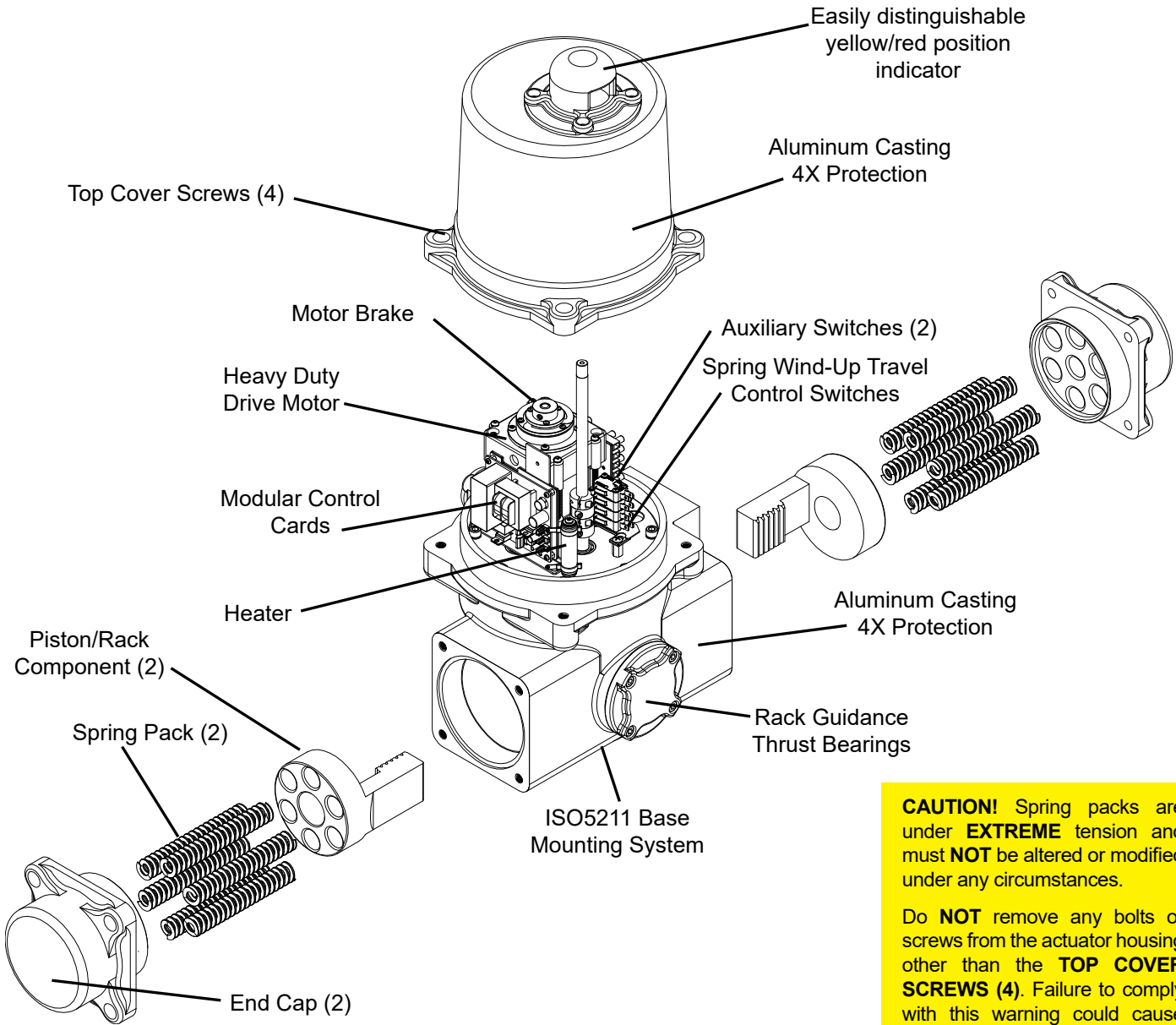

CAUTION! Spring packs are under **EXTREME** tension and must **NOT** be altered or modified under any circumstances.

Do **NOT** remove any bolts or screws from the actuator housing other than the **TOP COVER SCREWS (4)**. Failure to comply with this warning could cause **severe bodily injury.**

FM19_PAD CCW 24 2S4 Ver J 021423

Switch Logic Map and Switch/Cam Arrangement

Switch sequencing data is provided in the table to show the change-of-state points during the rotation of the actuator from CCW to CW and back again. The red bar shows when that terminal makes with its respective common.

Switches 1 and 2 are set at the factory and should NOT be changed. The INCLUDED auxiliary switches SW3 & SW4 are for terminals A thru F and those set points may be modified if need be.

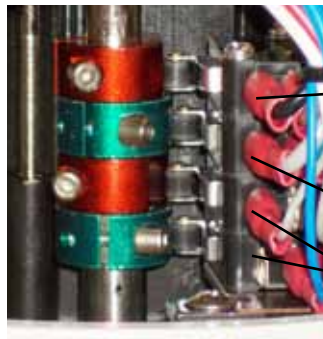

SW4 CW AUX
(Factory Set - Adj)

SW3 CCW AUX
(Factory Set - Adj)

Used by Controller

CW		CCW		Terminal ID#
-5°	0°	5°	85° 90° 95°	
Fully UNLOADED				F
Not Fully UNLOADED				E
UNLOADED Common				D
		Fully LOADED		C
		Not Fully LOADED		B
		LOADED Common		A

Commissioning

After completing all mounting and wiring procedures and main power is available, it is now possible to commission the actuator.

1. For units with a handwheel, utilize the handwheel to rotate the actuator and damper, valve or other connected device through its full travel from UNLOADED to LOADED and back again to check for any possible interference.
Do NOT utilize any mechanical advantage devices to rotate the handwheel (pipes, wrenches, extension bars, etc.). The spring will drive the device CCW, following the rotation of the handwheel.
2. Apply correct power to the unit.
3. Measure correct power on terminals 7 (Hot / L1) & 1 (Neu / L2) on the switch board.
4. Command the field device to generate a signal to drive the actuator towards the LOADED position.
The actuator rotates in a CW direction (as viewed from above).
5. Actuator will stop when it reaches it's LOADED position.
6. Command the field device to generate a signal to drive the actuator towards the UNLOADED position.
The actuator spring returns in a CCW direction (as viewed from above).
7. Actuator will stop when it reaches it's UNLOADED position and the handwheel (if equipped) is not blocking the full spring return positioning.
8. Actuator is now commissioned and operational.

Troubleshooting

Spring Return Actuator UNLOADED position and not restarting on power-up

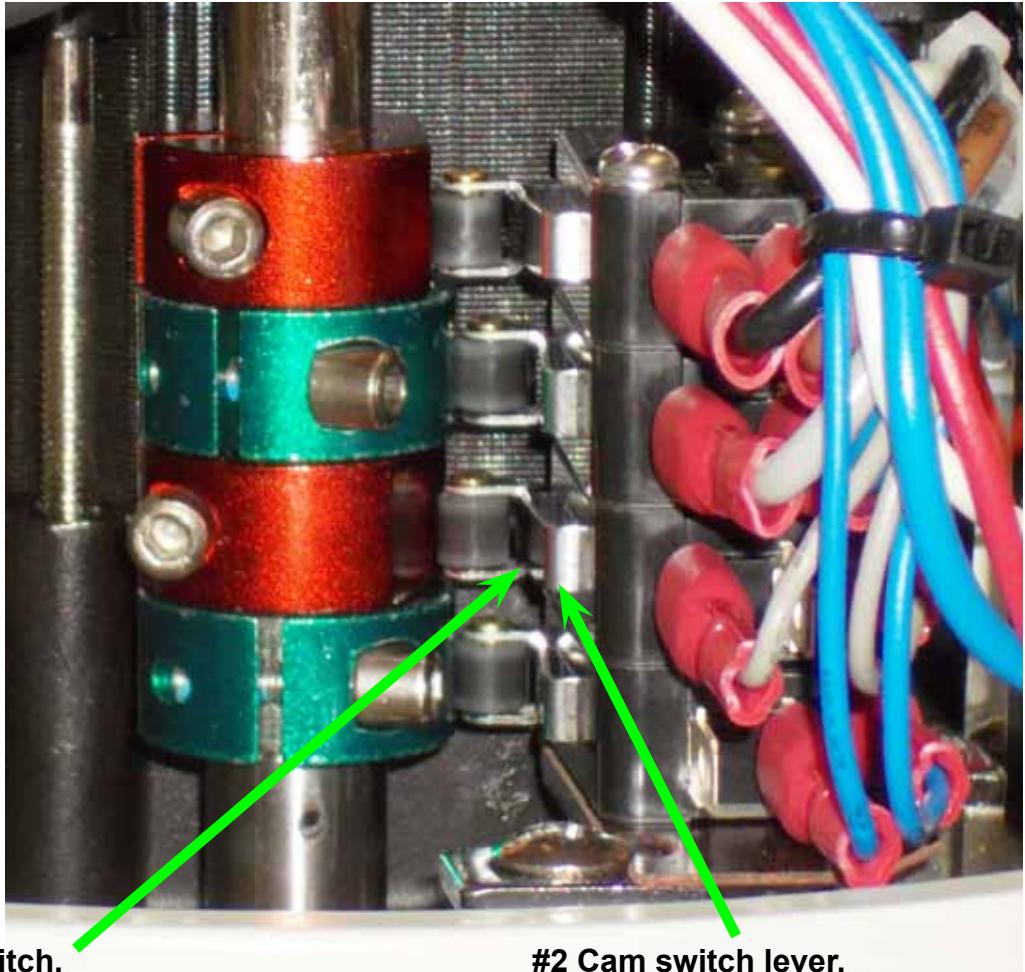

#2 Cam switch.

#2 Cam switch lever.

At actuator UNLOADED position you should be able to depress the #2 switch LEVER and hear it “click”.

Press towards black switch body to hear “click”. The switch will also click as it releases.

If no “click” is heard and the actuator is in fact UNLOADED, the cam is in the wrong position and is keeping the switch from changing state.

Use a 2.5mm hex key and rotate the RED #2 cam SLIGHTLY CCW until “click” is heard. Lightly resecure the cam in position to test. Secure fully after testing.

#2 Cam Positions: UNLOADED

Incorrect

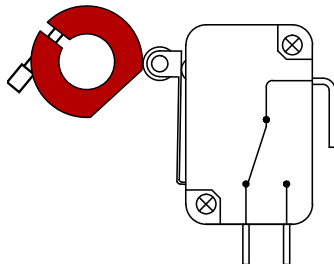

Lower RED cam position showing the switch roller riding high on the cam lobe. In this position, you cannot press on the switch roller lever and hear the switch “click”. In this position, the actuator will NOT restart after a power failure.

Correct

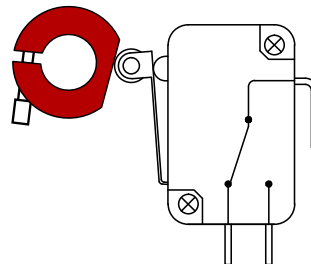

Lower RED cam position showing the switch roller sitting in the CORRECT position at the full spring return end of travel.

With the switch roller positioned as shown, the switch will “click” when the switch roller lever is pressed and the controller WILL restart after a power failure.

FM19_PAD CCW 24 2S4 Ver J 021423