



PROMATION ENGINEERING

Precision Actuation for Industry

Installation & Operation Manual

This IOM is for the following
ProMation Engineering Products:

PA-CW-1202S7
PA-CW-2302S7

PAO-CW-1202S7
PAO-CW-2302S7



This product is certified for use in the following hazardous locations:

Class I, Division 1, Groups C, D T4
Class II, Division 1, Groups E, F, G T130°C

Ex db IIB T4 Gb (For Canada)
Class I, Zone 1, AEx db IIB T4 Gb (For US)
Ex tb IIIC T130°C Db (For Canada)
Zone 21, AEx tb IIIC T130°C Db (For US)

and requires procedures and equipment rated for installation in those areas.





- **OPEN CIRCUIT BEFORE REMOVING COVER**
- **KEEP COVER TIGHT WHILE CIRCUITS ARE ALIVE**
- **SEAL REQUIRED WITHIN 18 INCHES(450 mm) OF ENCLOSURE (for Divisions only)**
- **SEAL REQUIRED WITHIN 2 INCHES (50 mm) OF ENCLOSURE (for Zones only)**
- **WARNING – AFTER DE-ENERGIZING, DELAY 10 MINUTES BEFORE OPENING**
- **CAUTION- USE FASTENERS WITH YIELD STRESS \geq 700MPa.**

Table of Contents

2 Product Specifications

3 Spring Return Theory of Operation

4 Shipping and Handling

4 Product Mounting and Setup

4 Installation Notes

5 Wiring Diagram

6 Adjusting Mechanical End-Stop for CW Position (UNLOADED)

7 Adjusting Cam for CW Position (UNLOADED)

7 Adjusting Cam for CCW Position (LOADED)

8 Adjusting the actuator Auxiliary Switches

9 Dimensional Data

10 Mechanical Data

11 Commissioning

12 Troubleshooting

13 Spring Return Manual Override Orientation -CW

Product Specifications

Actuator Specifications	PA/PAO	
Torque "lb/Nm	445"lbs/50Nm	
Supply Voltage	120vac	230vac
Max Inrush Current	2.0A	1.3A
Running Current	1.0A	0.7A
Motor	Split Phase Capacitor	
Runtime (90°@60Hz/vdc)	7 sec	7 sec
Runtime (90°@50Hz)	9 sec	9 sec
Runtime (spring)	3 sec	3 sec
Duty Cycle	50%	
Motor Starts	300 per hour	
Weight PA-PAO	66lbs/30kg-88 lbs / 40kg	
Mechanical Connections	ISO5211 F07 8pt 17mm	
Electrical Entry	(2) 3/4" NPT	
Electrical Terminations	12-16ga	
Environmental Rating	NEMA 4/4X	
Manual Override	7.6" Handwheel	
Control	On/Off	
Actuator Case material	Aluminum Alloy, Powder coated	
Motor Protection	230°F/110°C Thermal F* Class *Totally Enclosed Non-Ventilated Motors	
Ambient Temperature	-22°F to +149°F	
Operating Range	-30°C to +65°C	

The ProMation Engineering spring return actuators ("actuator"), are certified for use in hazardous locations: Class I, Division 1, Groups C, D T4, Class II, Division 1, Groups E, F, G T130°C; Ex db IIB T4 Gb; Ex tb IIIC T130°C Db (For Canada) and Class I, Zone 1, AEx db IIB T4 Gb, Zone 21, AEx tb IIIC T130°C Db (For US). The enclosures are NEMA Type 4X and IP68 (72h, 7m) rated.

The actuators use springs to drive the actuator to the failsafe position upon loss of power. The motor drives against the springs. A motor brake holds the actuator at the CCW end of travel. The motor brake is released upon loss of power.

Safety

Safety is a basic factor any time you maintain and operate mechanical equipment, especially in hazardous locations. Follow all local and national safety procedures when working in and around hazardous locations. Appropriate handling methods and proper use of tools and clothes can help prevent serious accidents -- accidents which can cause injuries to you or a fellow worker. Only competent and trained personnel should install, maintain and operate ProMation actuators. Any work related to this actuator must be carried out in accordance with this manual and related codes and regulations. Local workplace health and safety rules should always be followed.

- All electrical connections must be to national, state, and local codes and in accordance with hazardous location specifications for which this actuator is to be used.
- Reducers, glands, and/or conduit must be appropriately certified to be used in hazardous locations.
- To reduce the risk of ignition of hazardous atmospheres, an appropriately certified sealing fitting, cable gland or plug must be directly connected to the enclosure.
- An unused conduit port must be sealed with an appropriately certified threaded blanking plug.
-

Duty cycle

Duty cycle is the percent of time that an actuator spends running as a fraction of the total time. Duty Cycle is directly related to heat; excessively repositioning an actuator typically results in motor overheating which can cause permanent damage and/or reduced service life.

Duty cycle can be calculated as follows:

(example PA series actuator running 7 seconds ON and 70 seconds OFF)

Runtime = 7s, Total time = 7s + 70s = 77s, therefore this duty cycle would be 9% (7/77)

ProMation PA~D series actuators are designed for a maximum of 300 starts per hour (more than one start every 12 seconds).

Spring Return Theory of Operation

From the Spring CW position (UNLOADED), power is connected to terminals. While power is present, the actuator will respond to drive control signals depending on the model chosen.

- A 2 position unit will drive until it reaches its LOADED position (opposite the spring return direction).
- A Proportional control unit will follow an analog control signal for positioning and will HOLD until a modified control signal is received.
- In each of these models a motor brake unit is utilized to HOLD the actuator in position until commanded to move OR a loss of supply voltage.

If power is lost or removed at any time, the brake is released and the mechanical spring mechanism returns the actuator to its UNLOADED position. Once the spring mechanism has been released, the actuator will not drive under power again until:

- a) The unit has reached its UNLOADED position AND
- b) Power has been restored to the actuator AND
- c) Initial Power Startup delay of several seconds has elapsed.

If equipped with a manual override, while the actuator is UNLOADED the manual handwheel may be employed to position the actuator anywhere between the UNLOADED and LOADED position, and the actuator will HOLD in that position indefinitely, regardless of whether power is applied.

- The manual handwheel must return the actuator to its UNLOADED position BEFORE electrical operation of the actuator will be possible. This is a safety feature.
- If the actuator has been driven electrically to its LOADED position, the manual handwheel cannot be used to drive the actuator back to its UNLOADED position. This safety feature prevents the unexpected release of stored spring energy.
- Remote indication of actuator status can be accomplished by utilizing built-in auxiliary switches. After power has been restored these dry-contact form C switches will show when an actuator has been overridden, indicating the actuator will NOT operate under control again until it has been manually returned to the UNLOADED position (explained above).

Wire Sizing Chart

Wire sizing data is provided in the table to assist in the selection of the proper wire size for these actuators using various wire sizes over distance.

Please make sure to reference the correct voltage and do not exceed the indicated length of the wire run for each model.

	MAX distance between Actuator and Supply (feet)			
Actuator	PA(O)	PB(O) PC(O) PD(O)	PA(O)	PB(O) PC(O) PD(O)
Voltage	120VAC		230VAC	
Maximum Amperage (A)	2	11.5	1.3	5.9
	MAX distance between Actuator and Supply (feet)			
AWG				
18	413	-	1218	-
16	649	-	1915	422
14	1049	182	3093	682
12	1604	279	4731	1042
10	2727	474	8042	1772
8	4071	708	12003	2645

Shipping and Handling

1. The actuator is shipped from the factory in its Spring CW position (UNLOADED) position. Before mounting the actuator, make sure the MANUAL HANDWHEEL is able to free-wheel, indicating that the actuator is UNLOADED.
2. **NOTE: This actuator is shipped with TEMPORARY PLUGS installed in BOTH EMT ports. These temporary plugs MUST be replaced with proper fittings appropriate for use in the environment to which the actuator is to be installed. Utilize DRIP LOOPS in the conduit connections to prevent condensate from entering the actuator. Power MUST be supplied to the unit immediately upon installation to keep the anti-condensate heater warm. FAILURE TO PROPERLY STORE ACTUATOR VOIDS WARRANTY**
3. **Storage:** This unit should NOT be stored outside unless it is powered up and has proper conduit terminations. When this unit is NOT powered up, it should be stored in a clean, dry environment at all times.
4. This actuator has been **factory calibrated to operate between 0 degrees and 90 degrees. Most quarter-turn products will not require recalibration of these settings.** To change calibration, refer to pages 5-7 for instructions.



The actuator is shipped from the factory in its fully CCW position. The top illustration shows C for "CLOSE" on for CCW. The reverse is O for "OPEN".

Product Mounting and Setup

1. Fully CLOSE the valve or damper to which the actuator is to be mounted.
 - Keep in mind this spring CW actuator rotates CW (as viewed from above the unit) when the unit springs closed (UNLOADED).
2. Assemble necessary linkage components and attach the actuator to the driven device.
3. Tighten mounting bolts, making sure actuator is centered on the device drive shaft.
4. Utilize the handwheel to check for unobstructed manual operation from fully CCW to fully CW positions BEFORE applying power to the unit.
5. Make the electrical connections per wiring diagram
 - Connect POWER AND CONTROL to terminals marked 1, 3, and 7.
 - Terminals labelled A-F are for the (adjustable) aux switches. They are dry type Form C rated 10A @ 250vac MAX.
 - Terminals A-C (adjustable) are for the CCW position (LOADED).
 - Terminals D-F (adjustable) are for the CW position (UNLOADED).
6. Do NOT apply power at this time.

Installation Notes

- These actuators are designed to be used between a horizontal and upright position. Do NOT mount the assembly with the actuator top below a horizontal position.
- When installing conduit, use proper techniques for entry into the actuator. Use drip loops to prevent conduit condensate from entering the actuator.
- The mechanical travel stop is factory calibrated for the Spring CW (UNLOADED) position. The stop is NOT designed to adjust the Spring CW (UNLOADED) position by more than +/- 3 degrees.
- There is no mechanical stop for the LOADED position. Use caution when using the handwheel and make sure you do NOT rotate the actuator beyond the LOADED position. Observe the position by using the visual position indicator.
- Both NPT conduit ports MUST use proper equipment to protect the NEMA 4X integrity of the housing.
- The internal heater is to be used in ALL applications.
- Do NOT install the actuator outdoors or in humid environments unless it is powered up and the heater is functioning.
- Use proper wire size to prevent actuator failure (see chart on page 4 for proper wire sizing).
- All terminals accept 12-16AWG solid/stranded wire.
- **Isolation relays may be utilized to operate multiple actuators on parallel circuits.**



Bottom view of actuator showing the 8 point drive shaft and the ISO 5211 mounting hole pattern.

Wiring Diagrams

On/Off (2 Position) control is used for damper or valve applications where the requirement is for either fully open or fully closed positioning.

This actuator must drive to its end of travel opposite the spring fail position to stop motor. Loss of control signal or power before reaching its end of travel will cause the unit to spring return.

- Field Control Device may be relay contact, Switch or Triac type.
- Pilot device 10A MAX.
- Auxiliary switches are rated 10A @ 250vac MAX.
- Terminals A-F are dry type Form C.
- Terminals accept 12-16ga solid/stranded wire.
- Line supply voltage is to be $\pm 10\%$ of stated actuator voltage between line terminals H/N (120V) or L1/L2 (230V)

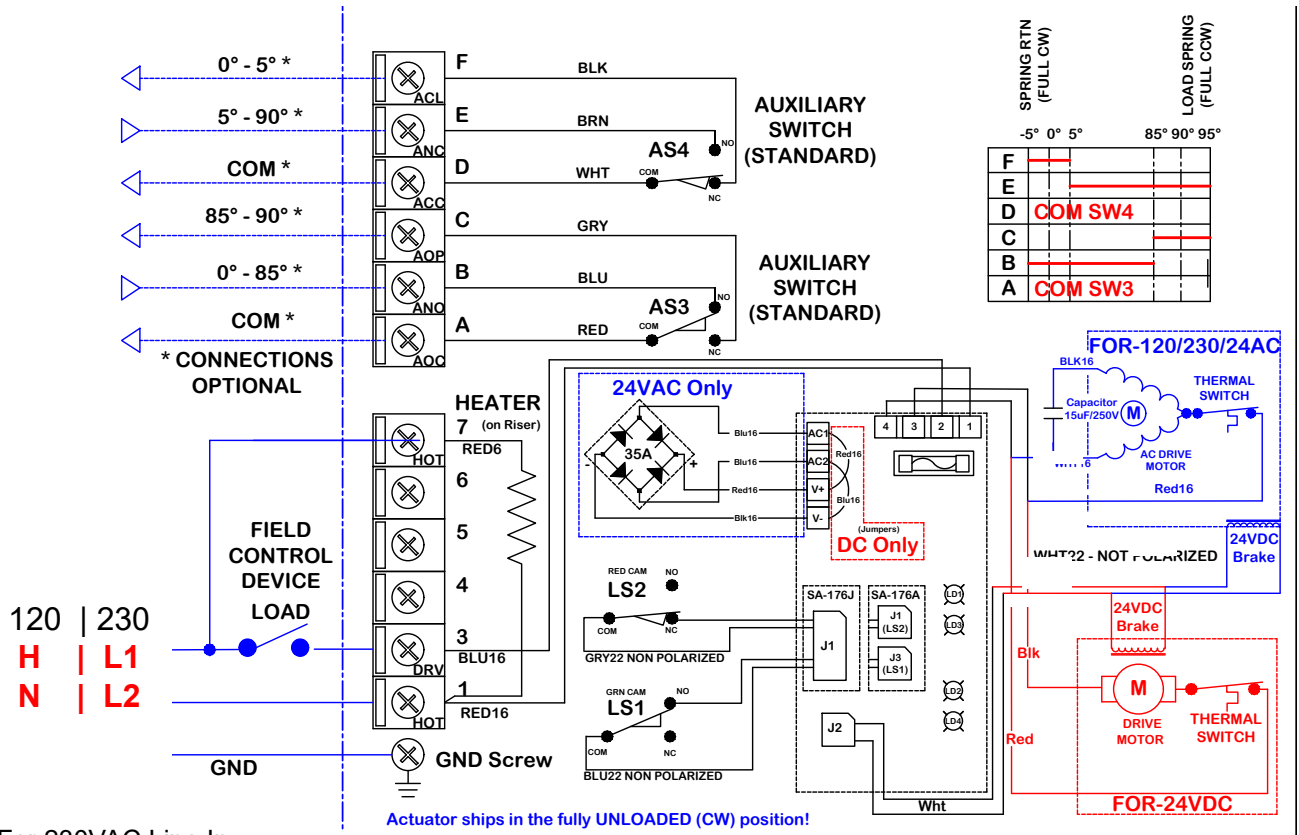

For 230VAC Line In

The potential between L1 and L2 should be 230VAC $\pm 10\%$

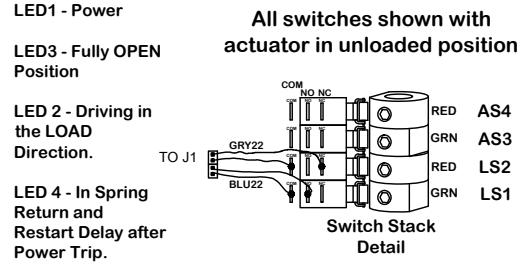

Adjusting Mechanical End-Stop for CW Position (UNLOADED)

This actuator has been factory calibrated to operate between 0 degrees and 90 degrees. Most quarter-turn products will not require recalibration of these settings. The following procedure is a reference for set-up, calibration, testing and use of the Spring Return quarter-turn electric actuators.

Do not make adjustments to this device until you have contacted the factory (+1 352-544-8436) for assistance. Damage to product as a result of incorrect cam and/or mechanical adjustments will VOID WARRANTY

1. Mount the actuator to the valve or damper to be actuated. Remember, the actuator is shipped in the spring return (UNLOADED) position. When viewed from ABOVE the actuator, the spring CW units spring closed (UNLOADED) in a CW direction. Make sure your valve or damper is in the CORRECT fail position before mounting the actuator to it.
2. Once the two components are bolted together, **apply power to the actuator**, HOT (7) and NEUTRAL (1) and generate a control signal to drive the actuator to the CCW (LOADED) position. Then remove power to allow the spring return system to drive the device back to the fail position -- CW (UNLOADED).



Remove adjustment housing cover.
Refer to step 3

Remove Adjustment Housing Cover

3. If it is determined that the CW (UNLOADED) end-stop position is not correctly aligned, it will be necessary to ADJUST the mechanical END STOP. To do this, remove the adjustment housing cover using a 6mm hex key.



Loosen lock nut.
Refer to step 4

Loosen Lock Nut and Adjust End Stop

4. There will be an adjustment nut and a lock nut inside the housing. Loosen the lock nut using a 32mm hex wrench, and while holding the nut, use a 22mm open end wrench to turn the adjustment nut. (CW to move the end stop more towards the LOADED direction, or CCW to move the end stop further AWAY from the LOADED direction). Do NOT turn the adjustment nut more than 5 turns in either direction!



Turn the adjustment nut to adjust UNLOADED position.
Refer to step 4

Tighten Lock Nut and Reattach Adjustment Housing Cover

5. Tighten the 32mm lock nut to secure the adjustment.
6. Reattach the cover removed in step 3.

Adjusting Cam for CW Position (UNLOADED)

Do NOT rotate the cams more than 3 degrees...Serious Damage to the actuator will result if the motor or handwheel is allowed to drive the gear train beyond the recommended spring compression!



Refer to steps 7-9

Adjust Cam 2

7. If new mechanical stop adjustment is made, the electrical travel cam indicating the failsafe position will need to be adjusted. With NO POWER APPLIED and the actuator in its failsage position (unsprung), Loosen the #2 (RED) cam set screw with a 2.5mm hex key. Rotate the cam to the RIGHT (CCW) a few degrees to reset the switch roller arm. Apply slight pressure to the set screw and SLOWLY rotate the hex key and cam to the LEFT (CW) until you hear the "click" on the second switch indicating that correct adjustment has been achieved. Tighten the cam set screw.

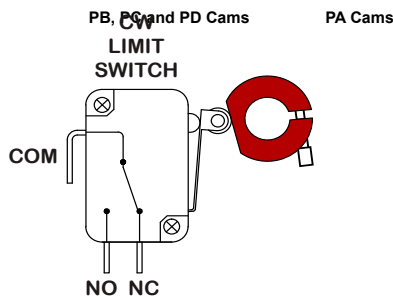

Note that this setting is only for "proof" that the unit has reached the full spring return position. **Adjusting this cam does not affect the spring return travel of the actuator.**

8. **NOTE: Incorrectly adjusted cams will prevent the actuator from running under power.**
9. Apply power and generate a control signal to drive the actuator approximately 20 degrees CCW. Remove power to let the spring return system drive back to the new end adjustment. Check the setting and repeat from step 3 if necessary.

Adjusting Cam for CCW Position (LOADED)

DO NOT attempt to adjust the CCW end of travel unless it is absolutely necessary.

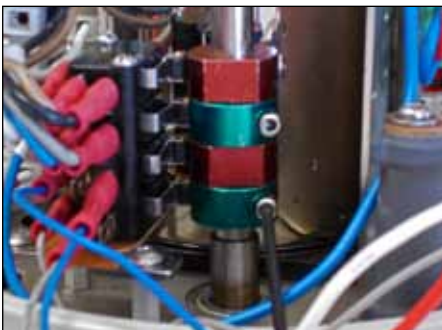

Refer to steps 11-12

10. Again apply power and generate a control signal to drive the actuator to the LOADED position. The actuator will stop and HOLD when it reaches it's end of travel.

DO NOT attempt to adjust the CCW end of travel unless it is absolutely necessary. For units without a handwheel, this can ONLY be done with power applied. If you remove power, the actuator will spring closed, making it impossible to make the adjustment. If you move the cam too far to the LEFT, the motor will drive the geartrain beyond the full compression of the springs. **This will DAMAGE the spring system and VOID THE WARRANTY. USE EXTREME CAUTION IF ADJUSTMENT IS NEEDED.**

For actuators equipped with a handwheel, the power may be turned off to use the handwheel to rotate to the CCW position. DO NOT fully compress the springs. This will DAMAGE the spring system and VOID THE WARRANTY. Rotate the handwheel to the freewheeling position prior to restoring power.

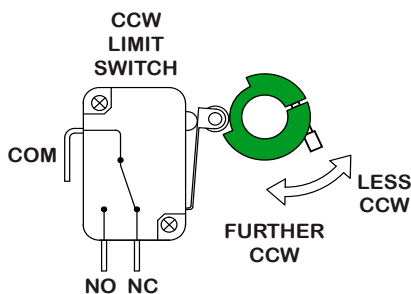

Adjust Cam 1

11. If the STOP point is incorrect, the #1 (GREEN) cam must be adjusted. Use a 2.5mm hex key to loosen the cam set screw. SLOWLY rotate the hex key rotating the cam to the LEFT (CW) to drive FURTHER CCW, or to the RIGHT (CCW) to drive LESS CCW.

12. Tighten the cam set screw.

Adjusting the actuator Auxiliary Switches



Cam 4

Adjust Cam 4

1. The fourth (RED) cam is the CW auxiliary switch adjustment. Spring return the actuator to its CW position. Then use a 2.5mm hex key to free up the cam set screw. Once it is free, rotate the hex key to the RIGHT a few degrees to reset the switch roller arm. Then snug the set screw up against the camshaft until slight pressure is felt. Then SLOWLY rotate the hex key and cam to the LEFT until you hear the “click” on the fourth switch. Continue to rotate the cam between 3 and 5 degrees to the LEFT to make sure the auxiliary cam switch changes state before the actuator reaches its end of travel electrically. Tighten the cam set screw.



Cam 3

Adjust Cam 3

1. The THIRD (GREEN) cam is the CCW auxiliary switch adjustment. Drive the actuator to its CCW position. Then use a 2.5mm hex key to free up the cam set screw. Once it is free, rotate the hex key to the LEFT a few degrees to reset the switch roller arm. Then snug the set screw up against the camshaft until slight pressure is felt. Then SLOWLY rotate the hex key and cam to the RIGHT until you hear the “click” on the third switch. Continue to rotate the cam between 3 and 5 degrees to the RIGHT to make sure the auxiliary cam switch changes state before the actuator reaches its end of travel electrically. Tighten the cam set screw.

Failsafe and Handwheel Alignment



Check to insure that the top indicator matches the failsafe (unsprung) position of the flow control device it is being assembled to. Typically actuator will indicate the failsafe position is CLOSED. If the flow control device is fail OPEN, the top indicator must be rotated 90 degrees to agree with the failsafe OPEN position



The rotation indicator tag on the handwheel (if present) must match the rotation of the actuator to the CLOSE position of the flow control device. Check to insure Handwheel rotates in the proper direction for the flow control device.

If the rotation to the CLOSE position does not match the rotation needed to move to the CLOSE position, remove the indicator tag and reinstall to the correct rotation direction. The rotation to the CLOSE position may be against the spring direction.

Mechanical Data

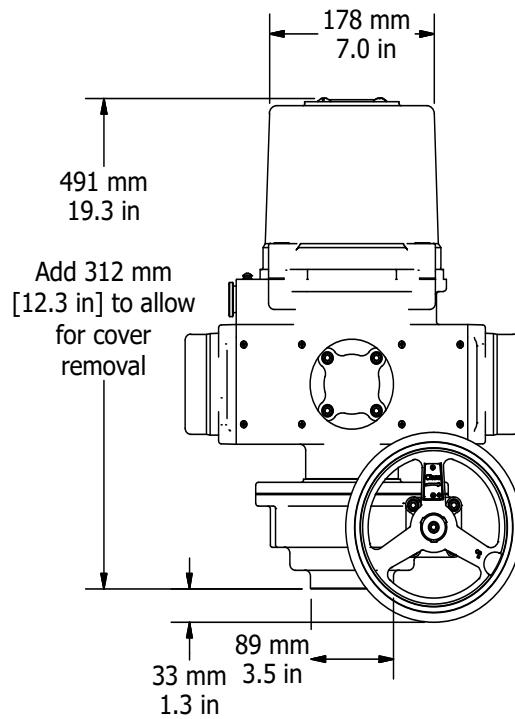
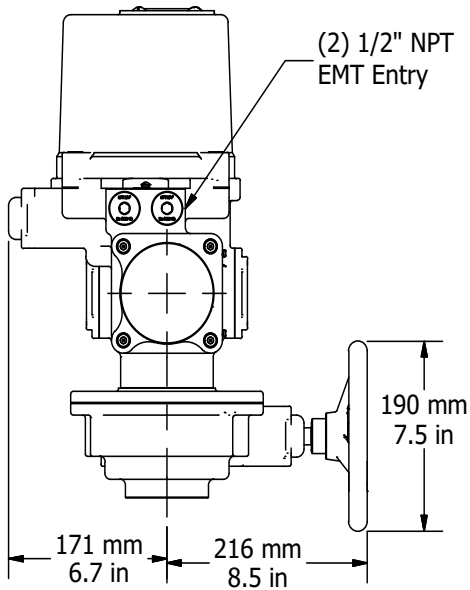
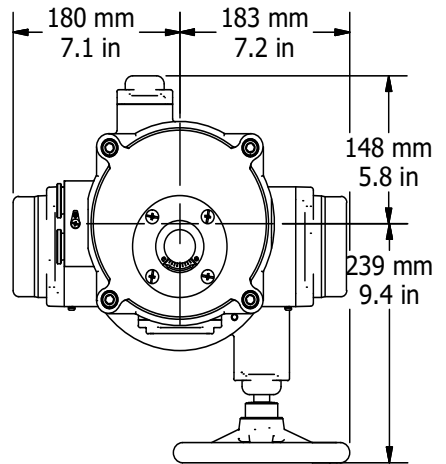
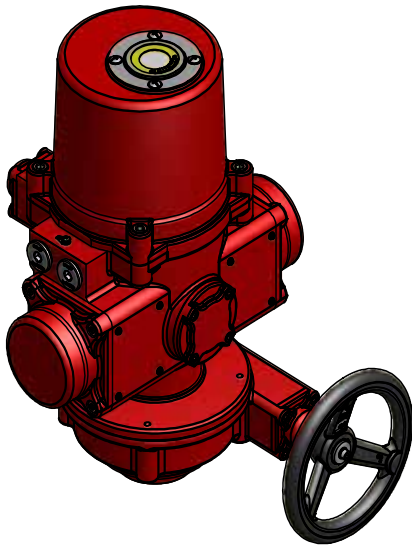

Drive Coupling Fabrication Data

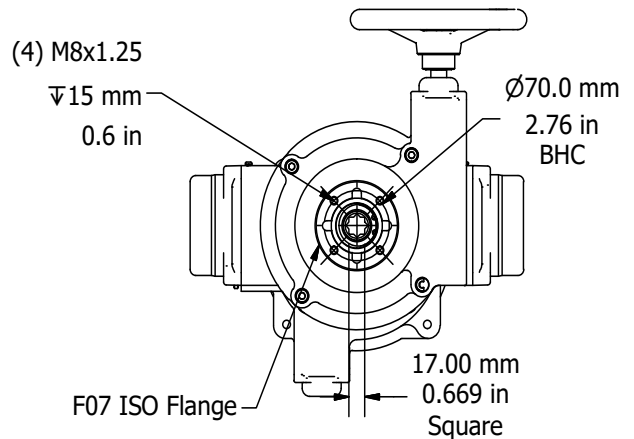
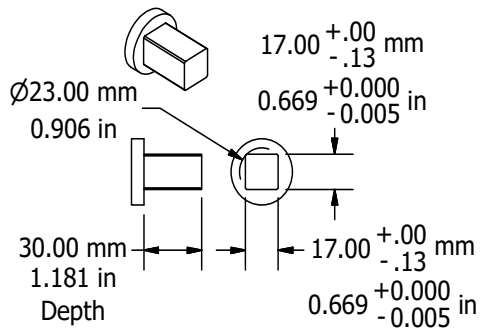

Mechanical Data

Spring Return Series Exploded View

(PAO-CW-1202S4 unit is shown)

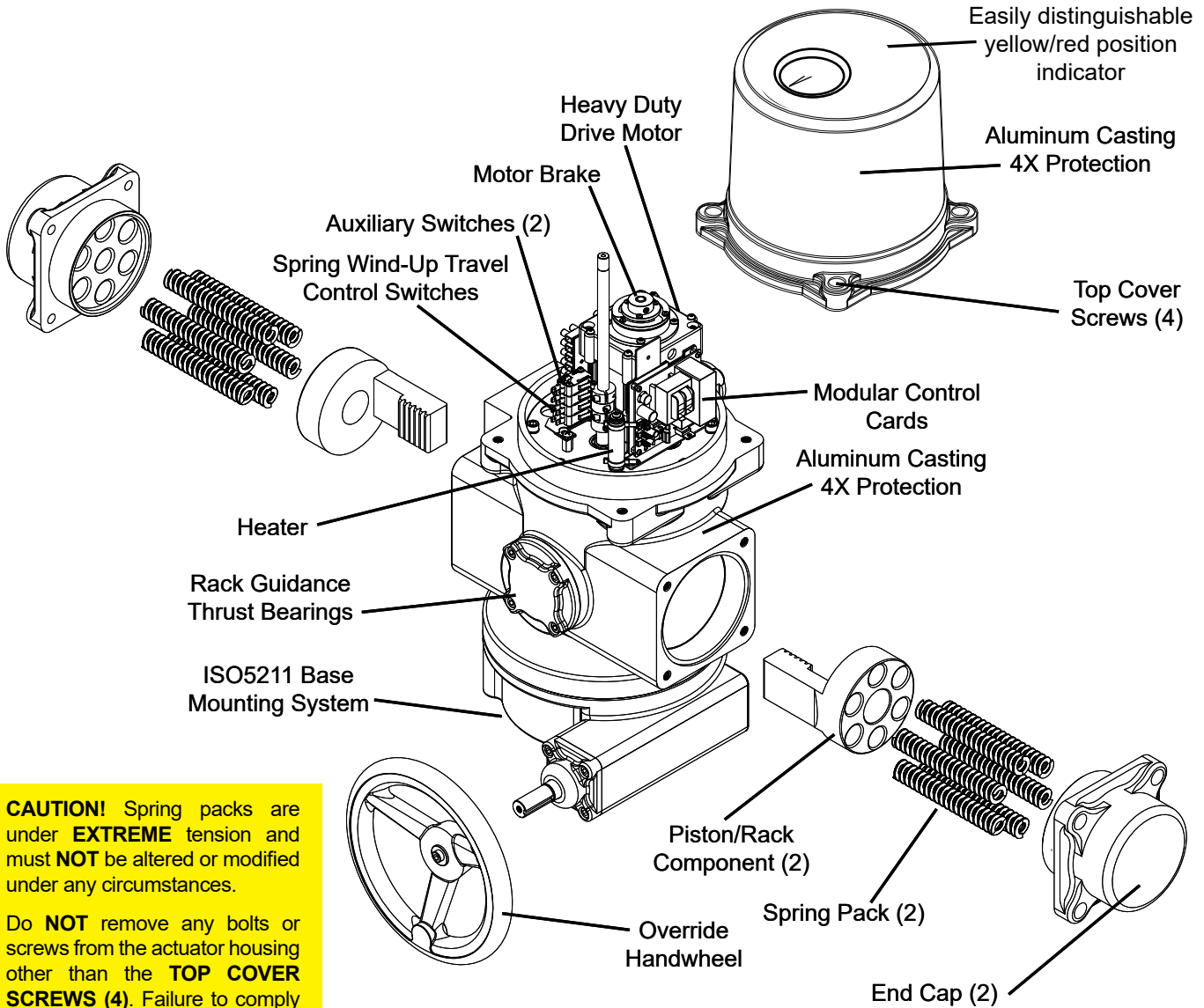

CAUTION! Spring packs are under **EXTREME** tension and must **NOT** be altered or modified under any circumstances.

Do **NOT** remove any bolts or screws from the actuator housing other than the **TOP COVER SCREWS (4)**. Failure to comply with this warning could cause **severe bodily injury**.

Switch Logic Map and Switch/Cam Arrangement

Switch sequencing data is provided in the table to show the change-of-state points during the rotation of the actuator from CCW to CW and back again. The red bar shows when that terminal makes with its respective common.

Switches 1 and 2 are set at the factory and should **NOT** be changed. The INCLUDED auxiliary switches SW3 & SW4 are for terminals A thru F and those set points may be modified if need be.

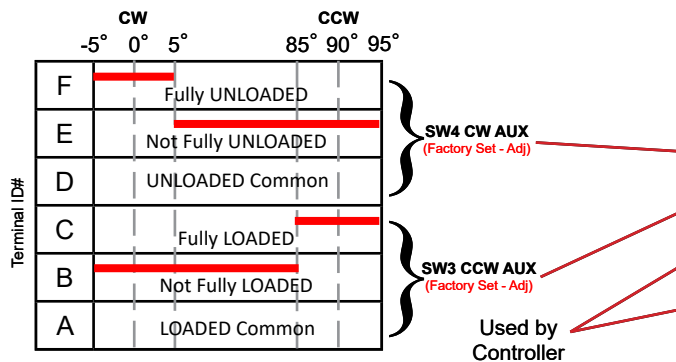

Commissioning

After completing all mounting and wiring procedures and main power is available, it is now possible to commission the actuator.

1. For units with a handwheel, utilize the handwheel to rotate the actuator and damper, valve or other connected device through its full travel from UNLOADED to LOADED and back again to check for any possible interference. Check to insure Handwheel rotates in the proper direction for the flow control device.
Do NOT utilize any mechanical advantage devices to rotate the handwheel (pipes, wrenches, extension bars, etc.). The spring will drive the device CW, following the rotation of the handwheel.
2. A fail CW actuator is typically used for a fail close device. However, by rotating the mounting 90 degrees on a valve or changing the linkage in a damper, a CW actuator could fail open.
3. Apply correct power to the unit.
4. Measure correct power on terminals 7 & 1 on the switch board.
5. Command the field device to generate a signal to drive the actuator towards the LOADED position.
The actuator rotates in a CCW direction (as viewed from above).
6. Actuator will stop when it reaches it's LOADED position.
7. Command the field device to generate a signal to drive the actuator towards the UNLOADED position.
The actuator spring returns in a CW direction (as viewed from above).
8. Actuator will stop when it reaches it's UNLOADED position and the handwheel (if equipped) is not blocking the full spring return positioning.
9. Actuator is now commissioned and operational.



Configurations of handwheel rotation indicator. Always check handwheel rotation with flow control device fail position.

CW Spring Return Actuator shown with handwheel and rotation indicator

Troubleshooting

Spring Return Actuator UNLOADED position and not restarting on power-up

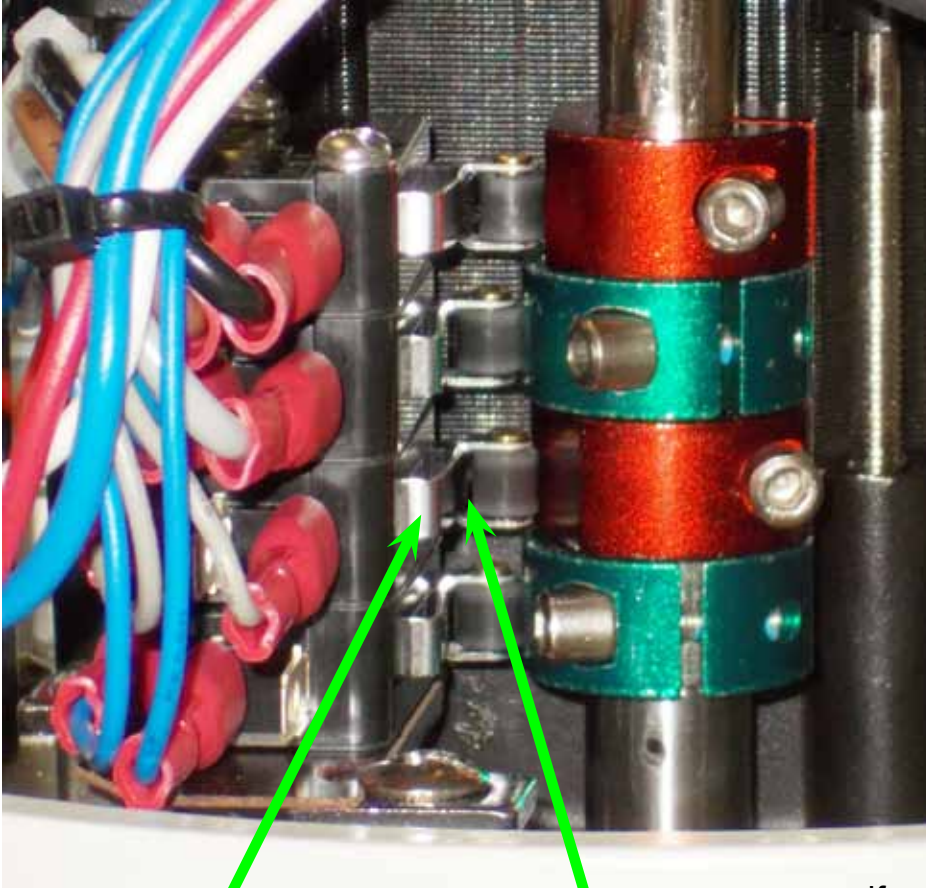

#2 Cam switch lever.

Press towards black switch body to hear "click". The switch will also click as it releases.

#2 Cam switch.

At actuator UNLOADED position you should be able to depress the #2 switch LEVER and hear it "click".

If no "click" is heard and the actuator is in fact UNLOADED, the cam is in the wrong position and is keeping the switch from changing state. Use a 2.5mm hex key and rotate the RED #2 cam SLIGHTLY CW until "click" is heard. Lightly resecure the cam in position to test. Secure fully after testing.

#2 Cam Positions: UNLOADED

Incorrect

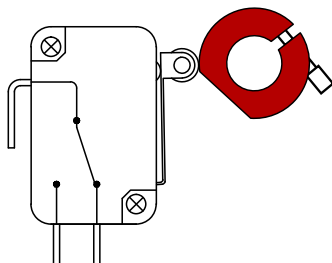

Lower RED cam position showing the switch roller riding high on the cam lobe. In this position, you cannot press on the switch roller lever and hear the switch "click". In this position, the actuator will NOT restart after a power failure.

Correct

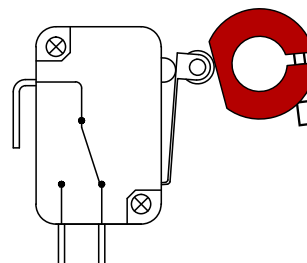

Lower RED cam position showing the switch roller sitting in the CORRECT position at the full spring return end of travel.

With the switch roller positioned as shown, the switch will "click" when the switch roller lever is pressed and the controller WILL restart after a power failure.

Spring Return Manual Override Orientation -CW

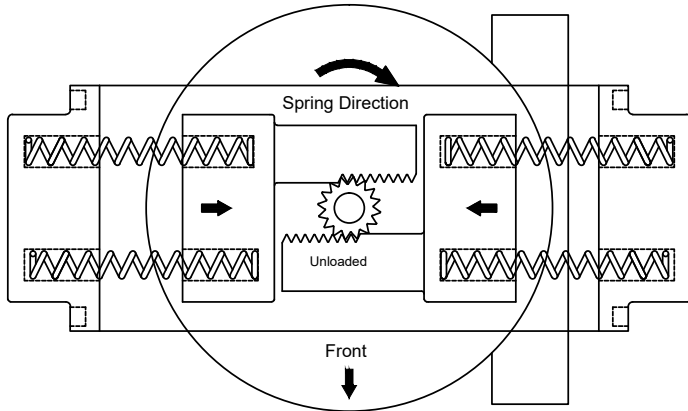

Actuator viewed from ABOVE

Default Configuration is Spring CW (from above).
Left side rack is in back, Right side rack is in front.

Diagrams describing the inner mechanical actions of a typical spring return actuator with manual override (OVD) system.

Graphic depicts the interaction of the unloading spring action to the racks which translate to rotation in the direction shown.

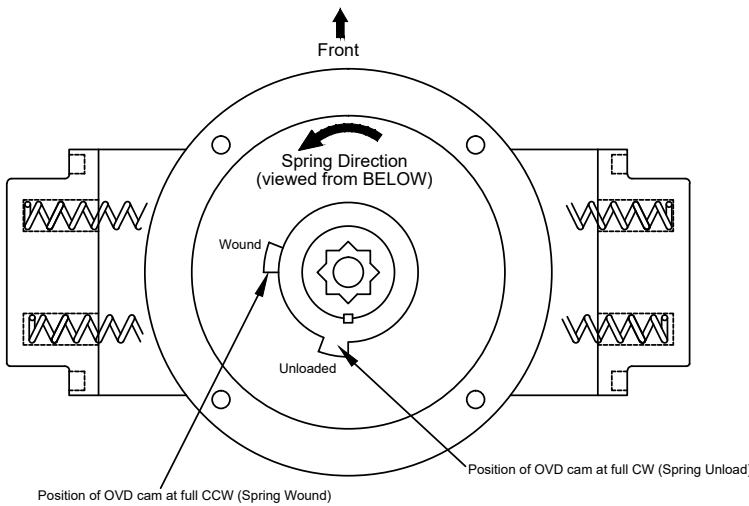

Actuator viewed from BELOW with OVD system removed

Graphic depicts the rotation of the output drive portion of the actuator as seen from below.

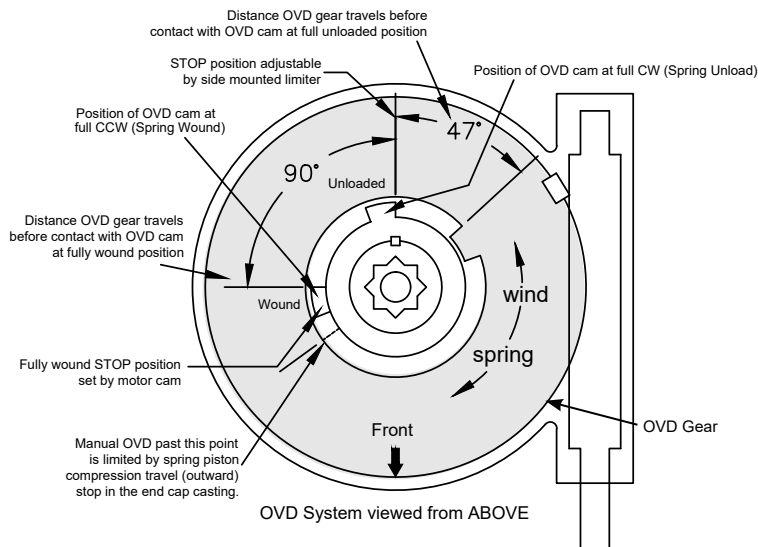

OVD System viewed from ABOVE

Graphic depicts the rotation of the override mechanism (OVD) as it relates to the output drive from above.

It shows the amount of rotational travel the OVD Gear makes (47°) before contacting the OVD cam (freewheeling) and the amount of rotational travel it makes (an additional 90°) while compressing the springs on the way to it's LOADED position.