

# PROMATION ENGINEERING

*Precision Actuation for Industry*

## Installation & Operation Manual

This IOM is for the following  
ProMation Engineering Products:

PX1.A-120N7

PX1.A-230N7



### Division System

CAN/CSA-C22.2 No. 0-10, CSA C22.2 No. 30-M1986, CSA C22.2 No. 25-17, FM 3600, FM 3615, FM 3616

Class I Division 1 Groups C,D T4

Ambient Temperature - 30 °C to + 70 °C ( - 22 °F to + 158 °F )

Class II Division 1 Groups E,F,G T130°C

Ambient Temperature - 30 °C to + 70 °C ( - 22 °F to + 158 °F )

### Zone System

CAN/CSA-C22.2 No. 0-10, CAN/CSA-C22.2 No. 60079-0, CAN/CSA-C22.2 No. 60079-1,

CAN/CSA-C22.2 No. 60079-31, UL 60079-0, UL 60079-1, UL 60079-31

Class I, Zone 1, AEx db IIB Gb T4

Class II Zone 21, AEx tb IIIC T130°C



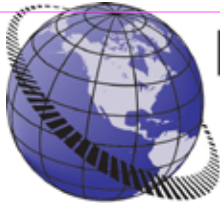

**Table of Contents**

2 ..... **Product Specifications**

3 ..... **Hazardous Location Notes**

5 ..... **Shipping and Handling**

5 ..... **Product Mounting and Setup**

5 ..... **Installation Notes**

6 ..... **Wiring Diagram**

7 ..... **Check End of Travel Settings**

7 ..... **Adjusting the actuator CCW and CW positions**

8 ..... **Adjusting the actuator Auxiliary Switches**

9 ..... **Mechanical Dimensions**

10 ..... **Mechanical Data**

11 ..... **Commissioning**

FM19\_PX1.A HV NZ Ver A\_111519



## Product Specifications

Actuator Specifications	PX1.A	
Torque "lb/Nm	445"lbs/50Nm	
Supply Voltage	120vac	230vac
Max Inrush Current	0.8A	0.4A
Running Current	0.6A	0.3A
Motor	AC Capacitor Type	
Runtime (90°@60Hz/vdc)	20 sec	
Runtime (90°@50Hz)	20 sec	
Duty Cycle	30%	
Motor Starts	1200 per hour	
Weight	5lbs/3kg	
Mechanical Connections	ISO5211 F07 8pt 17mm	
Electrical Entry	(2) 1/2" NPT	
Electrical Terminations	14-18ga	
Environmental Rating	NEMA 7/IP68	
Manual Override	8mm Socket Drive	
Control	On/Off/Jog	
Actuator Case material	Aluminum Alloy, Red Powder coated	
Motor Protection	230°F/110°C Thermal F* Class *Totally Enclosed Non-Ventilated Motors	
Ambient Temperature	-22°F to +158°F	
Operating Range	-30°C to +70°C.	

## Introduction

The following procedure is to be followed for set-up, calibration, testing and use of the P Series quarter-turn electric actuators. Each unit is shipped from the factory with initial calibration of cams and switches completed for 0-90 degree operation. However, these are general settings and serve as a starting point for proper calibration of the actuator in its real-world application. There are no mechanical stops on this model.

## Safety

Safety is a basic factor any time you maintain and operate mechanical equipment. Use of proper handling methods, tools and clothes can help prevent serious accidents -- accidents which can cause injuries to you or a fellow worker. This manual was created to enable a trained user to install, adjust and troubleshoot your ProMation P Series actuator.

Only competent and trained personnel should install, maintain and repair ProMation Actuators. Any work related to this Actuator must be carried out in accordance with this manual and related codes and regulations. Local workplace health and safety rules should always be followed.

## Duty cycle

Duty cycle is the percent of time that an actuator spends running as a fraction of the total time. Duty Cycle is directly related to heat; overusing an actuator typically results in motor overheating which can permanently damage it. Overheating also consumes more electricity. Generally speaking, the hotter a motor becomes, the longer 'rest' it needs to cool down so it runs efficiently.

# **Hazardous Location Actuators**

## **1 General Information**

- **Failure to follow safety instructions may cause serious injury, equipment damage, or void warranty**

### **1.1 Safety Instructions**

- Installation, maintenance and repair must be performed by trained personnel.
- The handling shall follow the safety and warning instructions contained in this manual.
- The user should read and follow instructions contained in this operation manual. Failure to do this may result in damages and void warranty. ProMation Engineering is not liable for damages due to operator negligence or misuse.
- All national, regional and local health and safety codes are to be followed when in installing and operating equipment.
- The surface temperature may exceed 60°C (140°F). Please check the surface temperature before operation, using an appropriate thermometer and protective clothing before operation.

### **1.2 Installation Notices**

- **Mount, calibrate, and test actuators only during non-hazardous conditions.**
- **All electrical connections must be to national, state, and local codes and in accordance with hazardous location specifications for which this actuator is to be used.**

#### **1.2.1 Hazardous Location Information**

- DO NOT install in ambient temperatures that exceed 70 °C (158 °F).
- DO NOT, under any circumstances, remove the cover of the actuator while in a hazardous location when the power is still live inside the actuator. This could cause ignition of a hazardous atmosphere.
- DO NOT, under any circumstances, use an explosion-proof electric actuator in a hazardous location that does not meet the specification which the actuator was designed for.
- When removing the actuator, care must be taken not to scratch, scar or deform the flame path of the cover or base of the actuator. That will negate the protection rating of the enclosure in a hazardous location.
- The explosion proof electric actuator is shipped with matched mating surfaces of the cover and base. When assembling or disassembly the cover from the actuator, match the mating number (QA code) of the top with the bottom. to assure hazardous location protection.
- Please read operation manual and wiring diagram carefully before installation.
- Verify that supply voltage is in accordance with the data on nameplate to prevent electrical component damage caused by incorrect power input.
- Turn power off before performing any installation, wiring or maintenance procedures.
- There are grounding devices both inside and outside of the actuator. Ground wires should be connected properly.
- The metal plugs in conduit entries are for transit only. For long term protection fit suitable flameproof cable gland and power cable should be with a minimum withstand temperature 105 °C (221°F).

## Hazardous Location Information (Continued)

- Do not touch any components on the PCB with metal tools or bare hands to avoid functional failure caused by static electricity discharge.
  - Do not parallel wire multiple actuators together without using isolation relay(s).
  - Use proper techniques when installing conduit and properly seal the connection. Do not mount the actuator with conduit entries in such a position that allows condensation to enter the unit.
  - Actuator should be installed in an upright or horizontal position. Do not mount upside down or below a horizontal position.
  - Periodically inspect actuator enclosure to prevent water intrusion and dust accumulation.
  - Check the marking and certificate number to see if it conforms to the indicated application.
  - All the parts of the housing are assembled in the right manner and fastened. USE FASTENERS WITH YIELD STRESS  $\geq 700\text{MPa}$ .
- 
- **KEEP COVER TIGHT WHILE CIRCUITS ARE ALIVE. AFTER DE-ENERGIZING, DELAY 10 MINUTES BEFORE OPENING THE COVER.**
  - **SEAL REQUIRED WITHIN 18 INCHES (450 mm) OF ENCLOSURE (for Divisions only).**
  - **SEAL REQUIRED WITHIN 2 INCHES (50 mm) OF ENCLOSURE (for Zones only).**
- 
- The actuator is delivered with two conduit entries plugged by metal plugs. Use cable glands rated for the corresponding hazardous location designation. The electrical supply cable must be suitable for power rating and with a temperature rating of greater than 105 °C (221 °F).

### CSA Testing

- Atmospheric pressure : 80 - 106 kPa.
- Ambient temperature: -30 °C to +70 °C (-22 °F to +158 °F).
- Air with normal oxygen content: 21 % (Volume).

## Shipping and Handling

1. This actuator is shipped in the FULLY CW (position indicator shows "CLOSE") position.
2. **NOTE, THIS ACTUATOR MUST HAVE WATER TIGHT HAZARDOUS LOCATION EMT FITTINGS WITH CONDUIT DRAINAGE INSTALLED AND POWER SUPPLIED TO UNIT TO KEEP THE HEATER WARM AT THE TIME OF INSTALLATION.**
3. **Storage: This unit should NOT be stored outside unless it is powered up and has proper conduit terminations. When NOT powered up, it should be stored in a clean, dry environment at all times.**
4. This actuator has been **factory calibrated to operate between 0 degrees and 90 degrees. Most quarter-turn products will not require recalibration of these settings.** If any travel adjustment is necessary, please refer to pages



The actuator is shipped from the factory in its fully CW position.

## Product Mounting and Setup

1. Fully CLOSE the valve or damper to which the actuator is to be mounted.
  - Keep in mind this actuator rotates CW (as viewed from above the unit) when driving CLOSED.
2. Assemble necessary linkage components and attach the actuator to the driven device.
3. Tighten mounting bolts, making sure actuator is centered on the device drive shaft.
4. Utilize the manual override (8mm hex output drive on side of actuator) to check for unobstructed manual operation from fully CW to fully CCW positions BEFORE applying power to the unit.

**NOTE: The P1.A main output drives 90° while the indicator rotates 180° in the opposite direction.**

**Warning: DO NOT operate manual override when power is present. Geartrain damage and personal injury may occur.**

**Do not use powered tools to turn the manual override -- it will DAMAGE the gear train or motor and VOID the warranty.**

5. Make the electrical connections per wiring diagram on page 6.
  - For operation only four connections are needed. The balance of the connections are used for options and features.
  - Terminals A-F on the switch card are for the (adjustable) aux switches. They are dry type Form C rated 3A @ 250vac MAX.
  - Terminals A, B & C are an aux switch for the open position (adjustable).
  - Terminals A, E & F are an aux switch for the closed position (adjustable).
  - Both Switches above share a common terminal "A".
6. Do NOT apply power at this time.

## Installation Notes

- There are no mechanical stops on this model.
- These actuators are designed to be used in either a horizontal or upright position. Do NOT mount the assembly with the actuator top below a horizontal position.
- When installing conduit, use proper techniques for entry into the actuator. Use drip loops to prevent conduit condensate from entering the actuator.
- Both NPT conduit ports MUST use proper equipment to protect the hazardous location integrity of the housing.
- The internal heater is to be used in ALL applications.
- Do NOT install the actuator outdoors or in humid environments unless it is powered up and the heater is functioning.
- Use proper wire size to prevent actuator failure (see chart on page 4 for proper wire sizing).
- All terminals accept 14-18AWG solid/stranded wire.
- **Do NOT parallel wire multiple actuators together without utilizing isolation relays! If this is your intention, please contact ProMation Engineering for a multiple actuator parallel wiring diagram.**



# Wiring Diagram

## On/Off/Jog Control

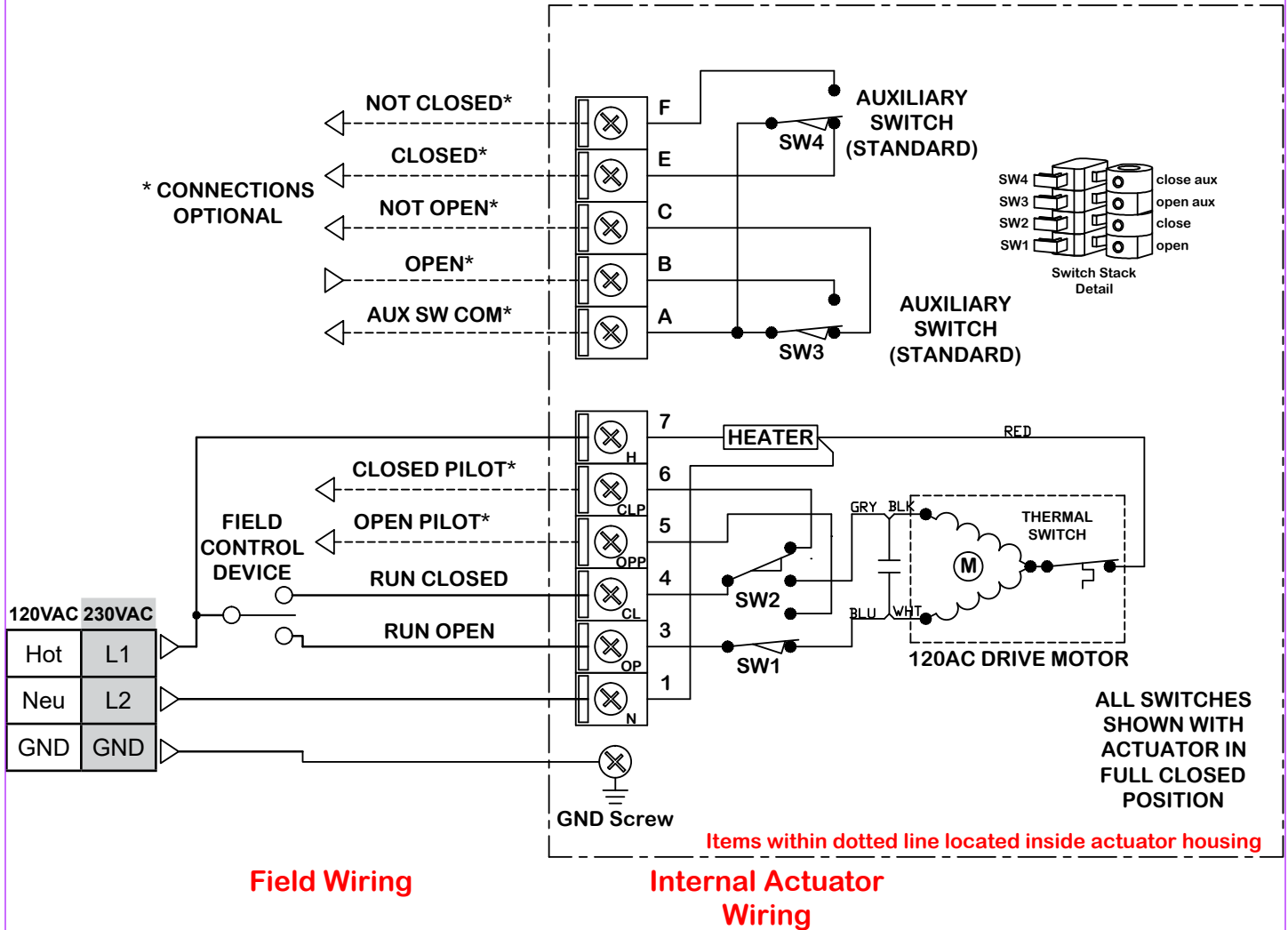

### Wire Sizing Chart

MAX. Distance between Actuator and Supply (feet)	MAX. Amps between Actuator and Supply (amps)	
Actuator/Voltage	P1.A 12VAC/DC	P1.A 24VAC/DC
Amps	0.5A	0.9A
Wire Gage		
18	1537	184
16	2865	289
14	3447	466

Wire sizing data is provided in the Wire Sizing Data table to assist in the selection of the proper wire size for ProMation P1.A Series actuators using various wire sizes over distance.

Please make sure to reference the correct voltage and do not exceed the indicated length of the wire run for each model.





## Check End of Travel Settings

The actuators are tested, calibrated and shipped in the Full CW position and End of Travel cams are set at 90 degrees from each other.

- A. Set the control device (valve or damper) to the closed position.
- B. Mount the actuator to the device to be controlled (valve or damper).
- C. Insure that the CW End of Travel cam trips the CW End of Travel switch at the correct CW point.
  - C.1. If the switch does not change state at the correct CW position, adjust CAM 2 per instructions below.
- D. Manually move (see Manual Override on page 6) the actuator so the valve or damper is in the fully CCW position.
- E. Insure that the CCW End of Travel cam trips the CCW End of Travel switch at the correct CCW point.
  - E.1. If the switch does not change state at the correct CCW position, adjust CAM 1 per instructions below.

## Adjusting the actuator CCW and CW positions (Cam adjustment)

**Remove power from this device BEFORE making any End of Travel cam adjustments.**



### Cam 1 Adjustment

1. The lower cam is Cam 1, the CCW end-of-travel adjustment. Once the actuator is at its required CCW position, with POWER OFF, use a 2.5mm hex key to free up the cam set screw. Once it is free, rotate the hex key to the RIGHT 10-15 degrees to reset the switch roller arm. Then snug the set screw up against the camshaft (CW) until slight pressure is felt. Then SLOWLY rotate the hex key pushing the cam to the LEFT until you hear the “click” on the bottom switch indicating that correct adjustment has been achieved. Tighten the cam.

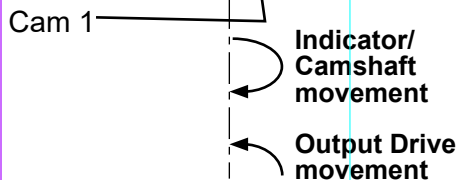
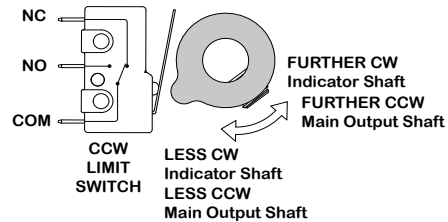

2. Apply power to the actuator and drive CW at least 15-20 degrees. Then drive the actuator CCW until the cam stops the electrical travel. Check to be sure this is the correct CCW position you require. Repeat step 1 if further adjustment is needed.
3. If using the Auxiliary Switches, adjust Cam 3 per instructions on page 6.

**NOTE: The P1.A main output drives 90° while the indicator/camshaft rotates 180° in the opposite direction.**

### Cam 2 Adjustment

1. The second cam is Cam 2, the CW end of travel adjustment. Once the actuator is at its required CW position with POWER OFF, use a 2.5mm hex key to free up the cam set screw. Once it is free, rotate the hex key to the LEFT 10-15 degrees to reset the switch roller arm. Then snug the set screw up against the camshaft (CW) until slight pressure is felt. Then SLOWLY rotate the hex key to the RIGHT until you hear the “click” on the second switch indicating that correct adjustment has been achieved. Tighten the cam set screw.
2. Apply power to the actuator and drive CCW at least 15-20 degrees. Then drive the actuator CW until the cam stops the electrical travel. Check to be sure this is the correct CW position you require. Repeat step 1 if further adjustment is needed. Remove power from the actuator.

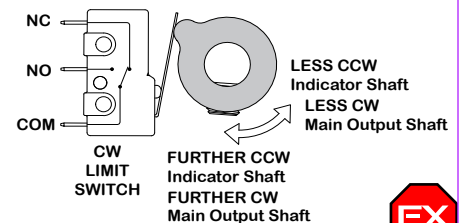

Cam 2

3. If using the Auxiliary Switches, adjust Cam 4 per instructions on page 6.



## Adjusting the actuator Auxiliary Switches

**Remove power from this device BEFORE making any End of Travel cam adjustments.**

### Cam 3 Adjustment

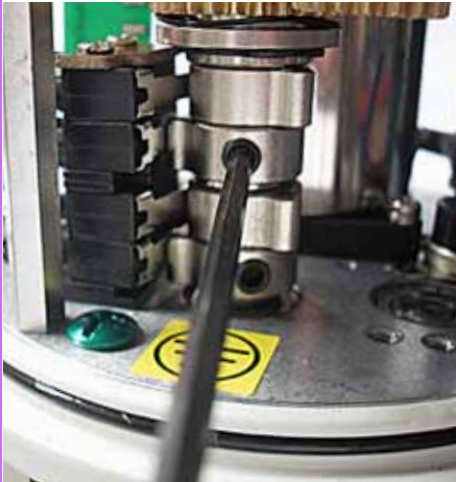

Cam 3

1. The third cam is Cam 3, the CCW auxiliary switch adjustment. Drive the actuator to its CCW position. Then use a 2.5mm hex key to free up the cam set screw. Once it is free, rotate the hex key to the RIGHT 10-15 degrees to reset the switch roller arm. Then snug the set screw up against the camshaft (CW) until slight pressure is felt. Then SLOWLY rotate the hex key and cam to the LEFT until you hear the “click” on the third switch. **Continue to rotate the cam between 3 and 5 degrees to the LEFT to make sure the auxiliary cam switch changes state before the actuator reaches its end of travel electrically.** Tighten the cam set screw.



Cam 4

### Cam 4 Adjustment

1. The fourth cam is Cam 4, the CW auxiliary switch adjustment. Drive the actuator to its CW position. Then use a 2.5mm hex key to free up the cam set screw. Once it is free, rotate the hex key to the LEFT 10-15 degrees to reset the switch roller arm. Then snug the set screw up against the camshaft (CW) until slight pressure is felt. Then SLOWLY rotate the hex key to the RIGHT until you hear the “click” on the fourth switch. **Continue to rotate the cam between 3 and 5 degrees to the RIGHT to make sure the auxiliary cam switch changes state before the actuator reaches its end of travel electrically.** Tighten the cam set screw.

**Warning: DO NOT operate manual override when power is present. Geartrain damage and personal injury may occur.**

**Do not use powered tools to turn the manual override -- it will DAMAGE the gear train or motor and VOID the warranty.**



Manual Override

# Mechanical Data

# PX1.A Series Dimensional Data

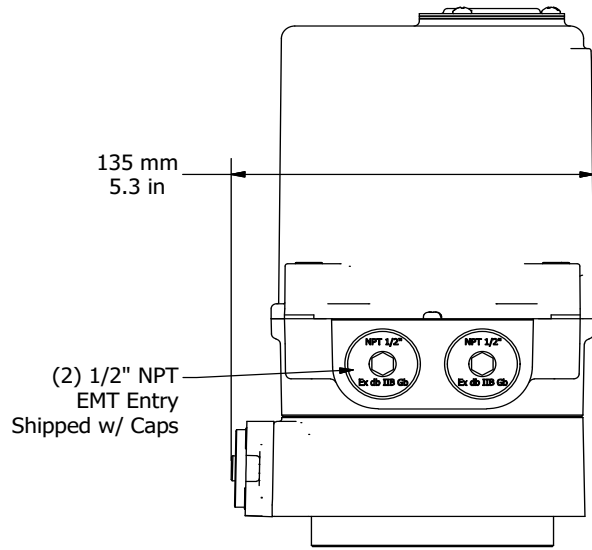
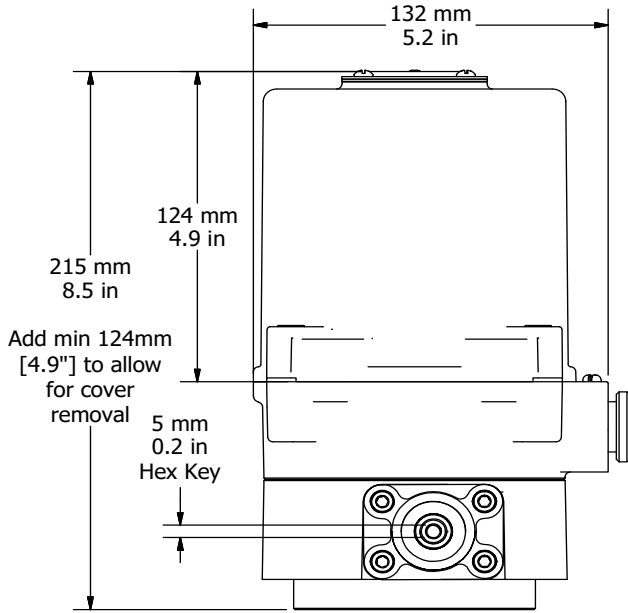
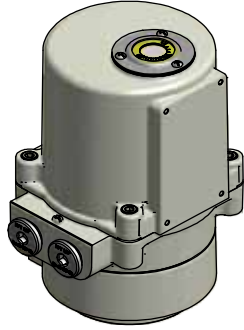

### Drive Coupling Fabrication Data

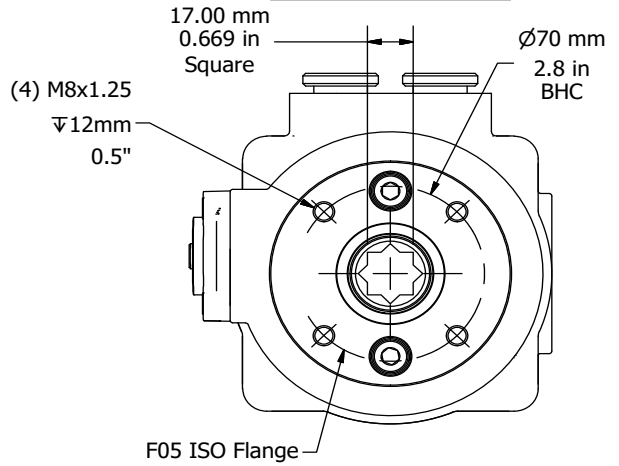
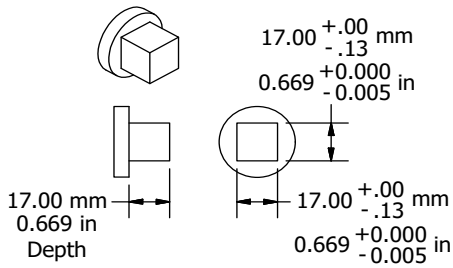

FM19\_PX1.A HV NZ Ver A\_111519



# Mechanical Data

## PX1.A Exploded View

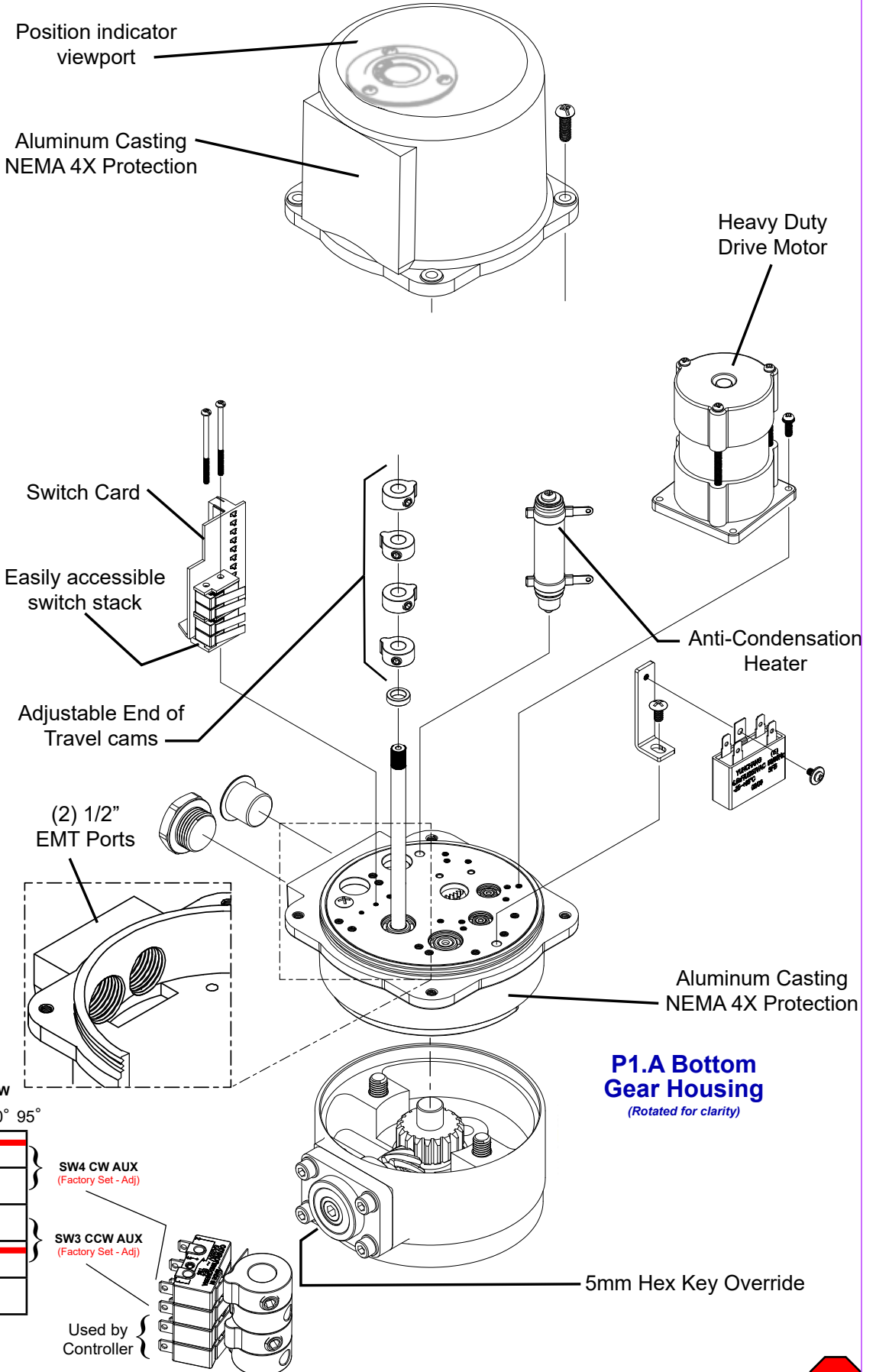

### Switch Logic Map and Switch/Cam Arrangement

Switch sequencing data is provided in the table below to show the change-of-state points during the rotation of the actuator from CCW to CW and back again. The red bar shows when that terminal makes with its respective common.

Switches 1 and 2 are set at the factory and should NOT be changed. The INCLUDED auxiliary switches SW3 & SW4 are for terminals 7 thru 12 and those set points may be modified if need be.

	CW			CCW		
	-5°	0°	5°	85°	90°	95°
F	Not Closed					
E	Closed					
C	Not Open					
B	Open					
A	Common Switch Terminal					

SW4 CW AUX  
(Factory Set - Adj)

SW3 CCW AUX  
(Factory Set - Adj)

Used by  
Controller

FM19\_PX1.A HV N7 Ver A\_111519



## Commissioning

This procedure will assume that the actuator is installed correctly both mechanically and electrically with correct power.

1. Apply the correct supply power to the actuator.
  - NOTE - Power is measured at terminals marked 1 & 7 on the actuator.
- 1.A NORMAL OPERATION
  - I. Power applied to terminals marked 1 & 3 will cause the actuator to run CCW.
  - II. Power applied to terminals marked 1 & 4 will cause the actuator to run CW.
2. Test Full CW and CCW Positions
  - 2.A Apply power to terminals marked 1 & 3
    - I. The actuator OUTPUT shaft will drive to the **full CCW** position while the INDICATOR/cam shaft rotates to the full CW position (as viewed from ABOVE the actuator).
    - II. If this is NOT the correct stop position, refer to Adjusting the actuator CCW position instructions for CAM 1 on Page 5 in this document.
  - 2.B Apply power to terminals marked 1 & 4
    - I. The actuator OUTPUT shaft will drive to the **full CW** position while the INDICATOR/cam shaft rotates to the full CCW position (as viewed from ABOVE the actuator).
    - II. If this is NOT the correct stop position, refer to Adjusting the actuator CW position instructions for CAM 2 on Page 5 in this document.



# Industrial Applications

ProMation Engineering actuators have been installed to operate process controls such as butterfly valves, ball valves, high performance valves, plug valves, gate valves and dampers, in a broad range of demanding industrial applications.

**Power  
Generation**



**Water  
Processes**



**Mining**



**Oil and Gas**



**Agriculture**

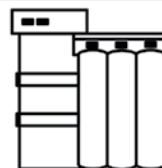

**Chemicals**



## Complete Support

ProMation Engineering is committed to providing superior customer support for your sales, project management and installation teams. Contact us today.

### Full Documentation

We offer complete wiring diagrams, field installation manuals and set up documentation for all our products, both in printed and digital form. We regularly host customized educational webinars for our customers.

### RapidQuote

Most quotes and estimates are generated within hours of the request.

### ProMation Engineering Services

ProMation Engineering can provide design and technical services for OEM's, projects with customized requirements and specialized operations.

ProMation Engineering follows a policy of continual product updates and enhancements. Our website is the best place to obtain the latest product documentation, including the wiring diagrams for these controllers. Visit us at [www.promationei.com](http://www.promationei.com) or use the code to link to the site.



**PROMATION  
ENGINEERING**

*Precision Actuation for Industry*

16138 Flight Path Drive  
Brooksville, FL 34604

Phone (352) 544-8436 Fax (352) 544-8439  
email: [sales@promationei.com](mailto:sales@promationei.com)