

Engineering Change Notice			
REV	Change Date	Description	Name
A			
B	07.09.2013	Transferred file into Inventor format	KHL
C	04.15.2014	Added tolerance on drive coupling data	KHL
D	10.07.2014	Pushed square dimension to three decimal places	KHL
E	04.08.2015	Added Isometric view of Drive Coupling and "Depth" tag for clarity	KHL
F			

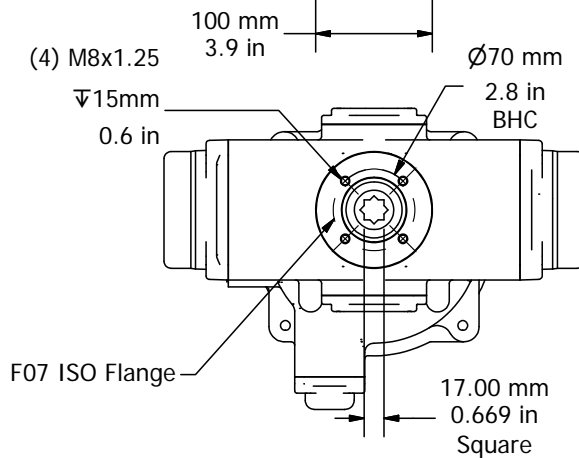
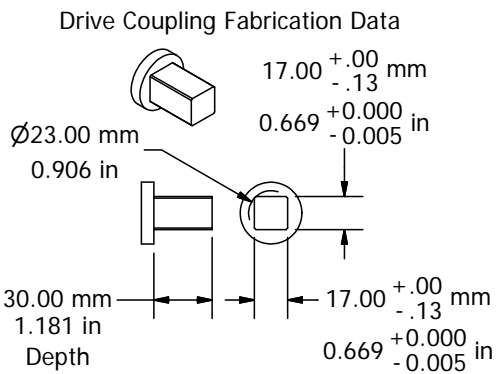
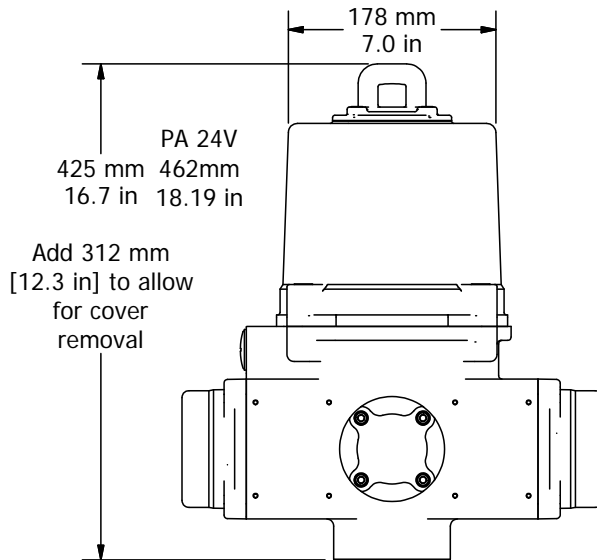
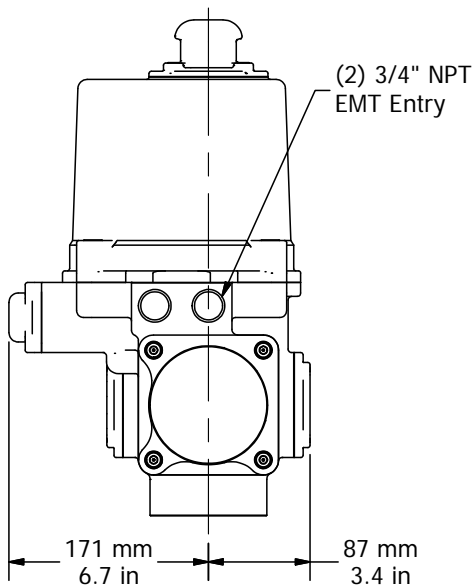
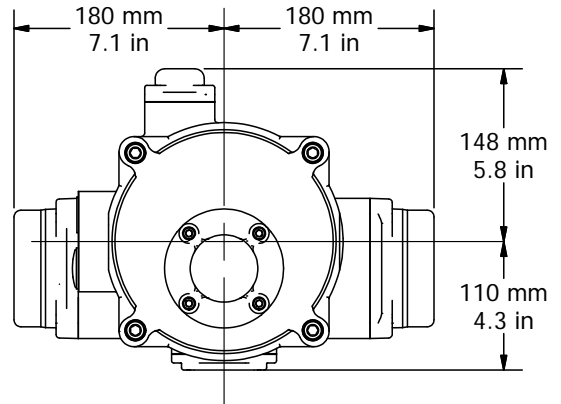
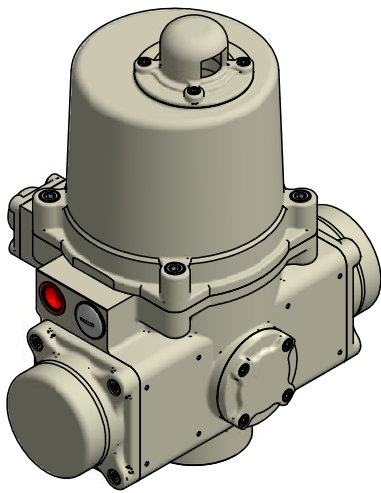

Drawn By KHL	Created: 7/9/2013	Part No.	<b>ProMaton Engineering, Inc.</b>	
Checked By KHL	Last Checked: 4/8/2015	This Document is the property of ProMaton Engineering, Inc. Distribution of this document without the written consent of the owner is Strictly forbidden. Failure to comply will incur a liability for Damages.		
Material Finish	Promation Engineering Inc. 16138 Flight Path Drive Brooksville, FL 34604 Phone: 352-544-8436 Fax: 352-544-8439		PA-CW Dim Data	Rev. E
Dimensional Tolerances (Unless Otherwise Noted): X ± 2.5mm [X.X ± .1] X.X ± .3mm [X.XX ± .01"] X.XX ± .13mm [X.XXX ± .005"] ALL TOLERANCE FEATURES IN mm			Dimensional Data for PA-CW Spring Return Actuators	
			NO SCALE	Sheet Number: 1