

Engineering Change Notice

REV	Change Date	Description	Name
A			
B			
C	09.06.2013	Transferred Dim Data drawing from AutoCAD to Inventor	KHL
D	05.14.2014	Added "Coupling Hardware NOT Shown" note	KHL
E			
F			

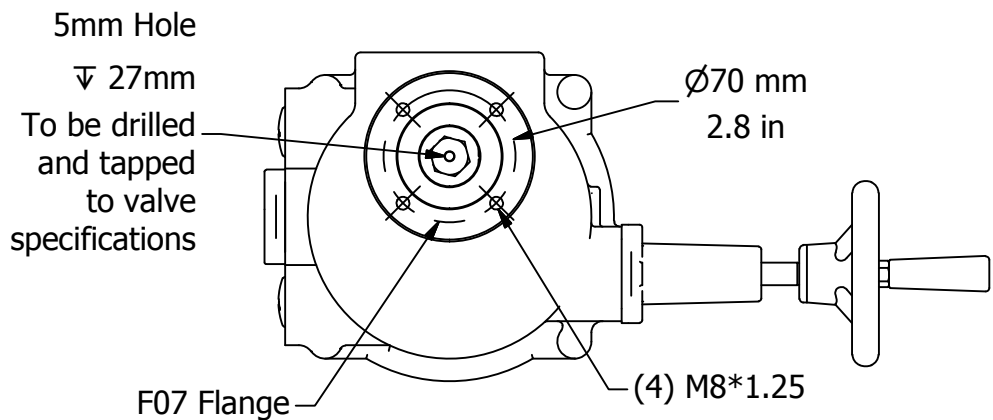
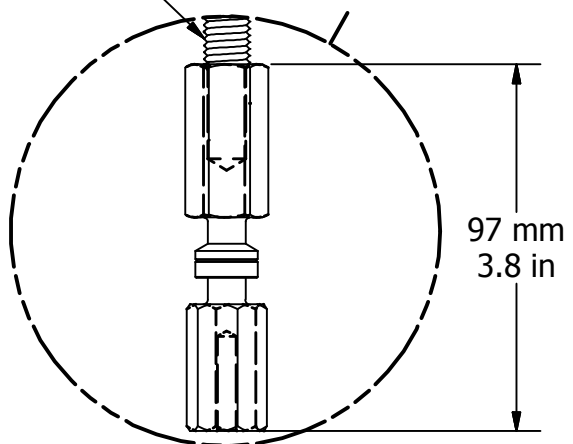
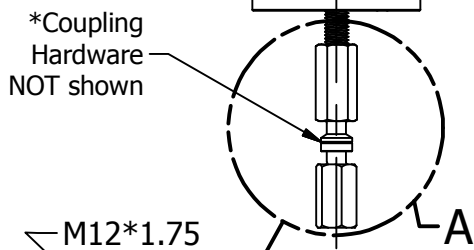
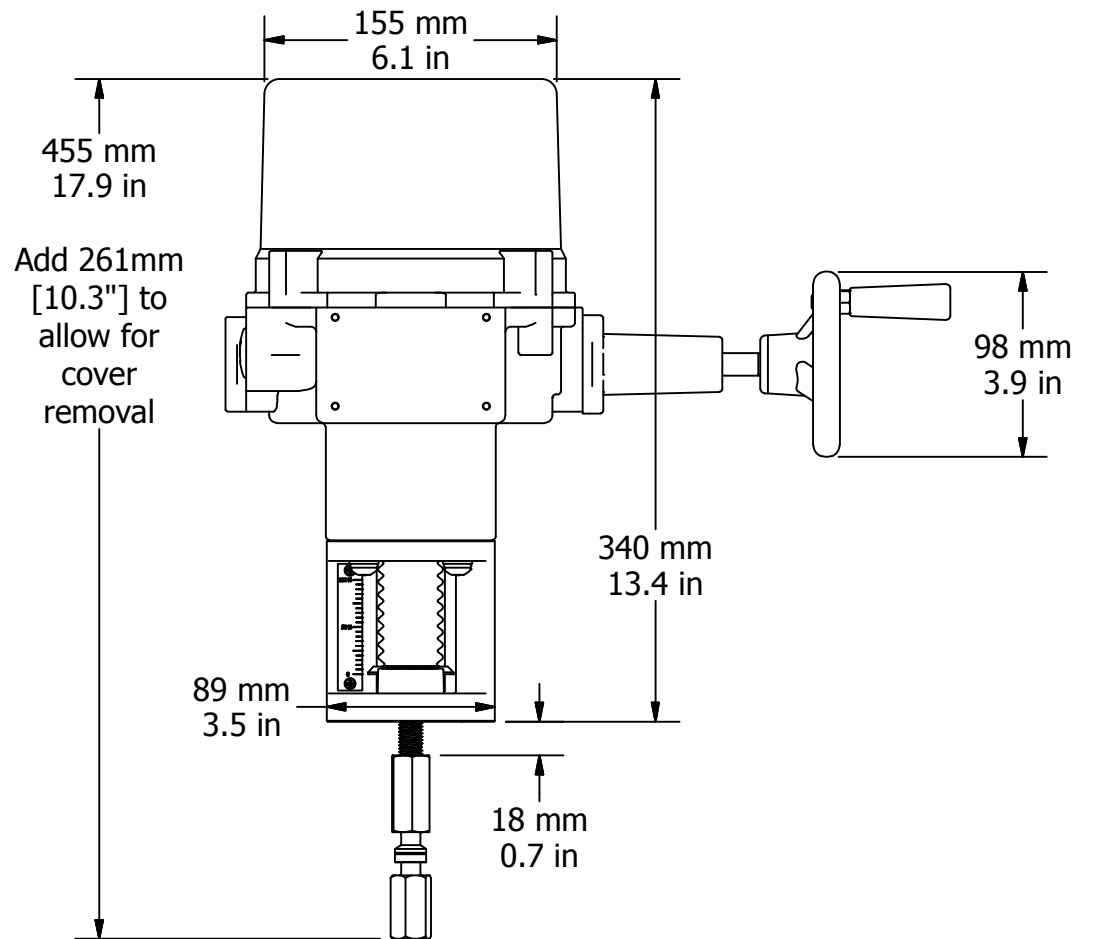
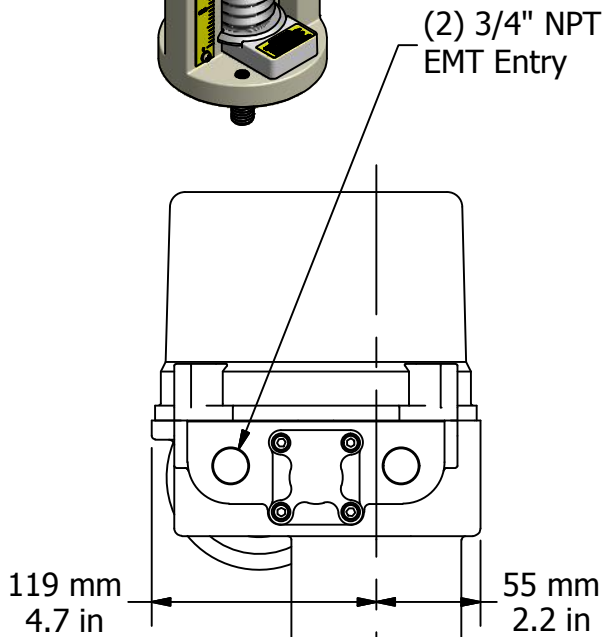
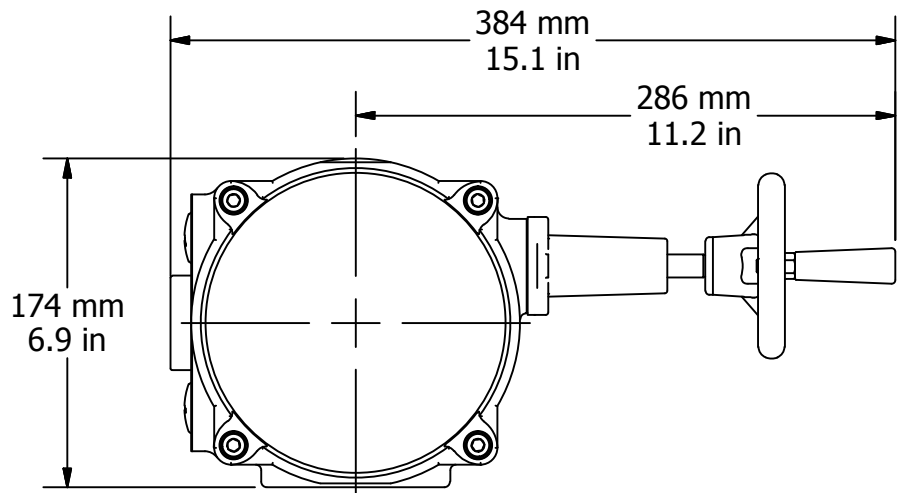
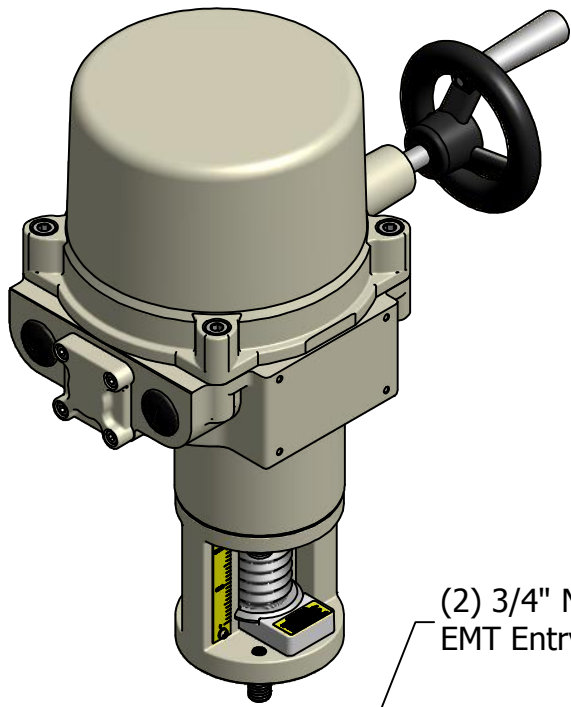

Drawn By KHL	Created: 9/6/2013
Checked By KHL	Last Checked: 5/14/2014
Material	Finish
Dimensional Tolerances (Unless Otherwise Noted): X.X ± .3 [X.XX ± .01] X.XX ± .13 [X.XXX ± .005] ALL TOLERANCE FEATURES IN mm	

Part No.	This Document is the property of ProMation Engineering, Inc. Distribution of this document without the written consent of the owner is Strictly forbidden. Failure to comply will incur a liability for Damages.
Promation Engineering Inc. 16138 Flight Path Drive Brooksville, FL 34604	
Phone: 352-544-8436 Fax: 352-544-8439	

ProMation Engineering, Inc.	
Dwg. Name	PL550_1100 Dim Data.idw
PL550/1100 Dim Data	Rev. D
Dimensional Data for PL550/1100 Actuators	
NO SCALE	Sheet Number: 1