

PZ, P1 & P1.A Dimensional Data

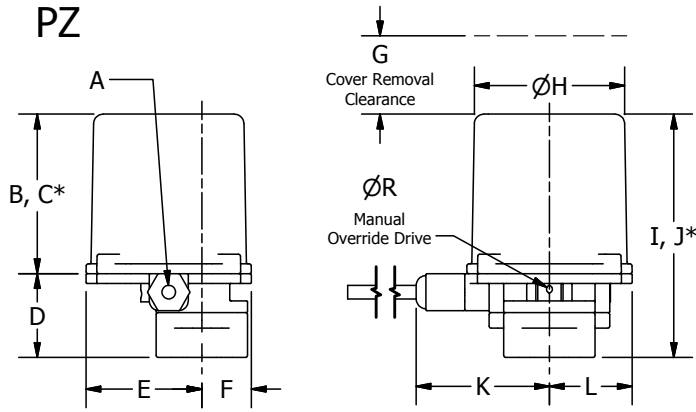

Drive Coupling Fabrication Data

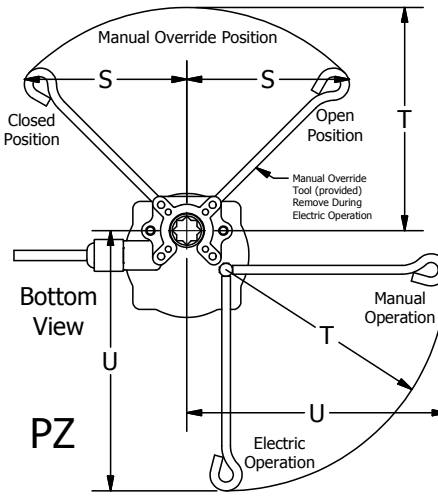
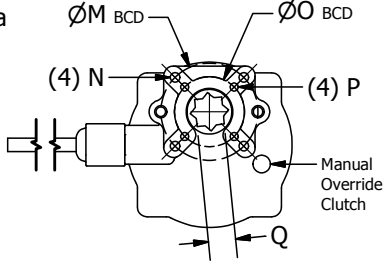
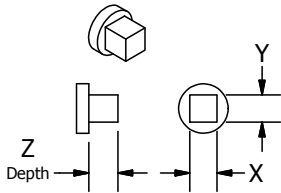

Manual Overrides

P1, P1.B, P1.C

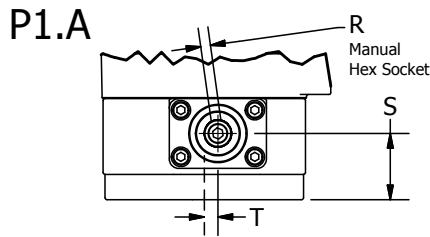
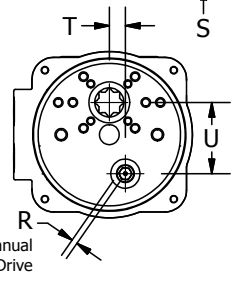
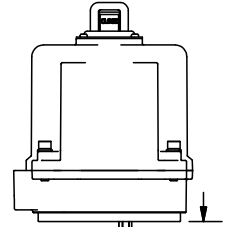

P1, P1.B, P1.C

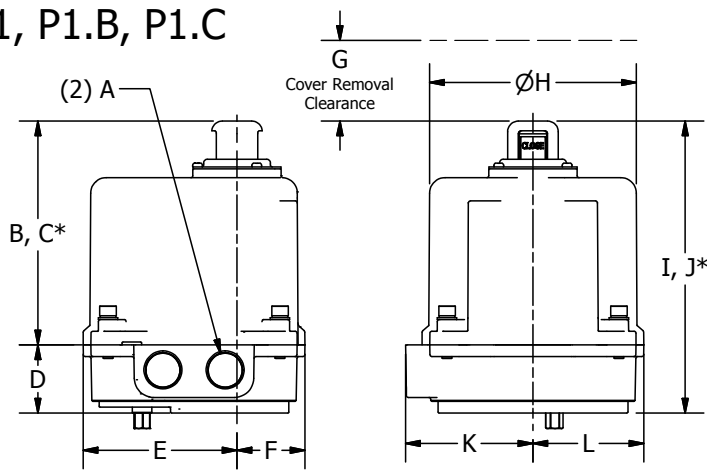

Drive Coupling Fabrication Data

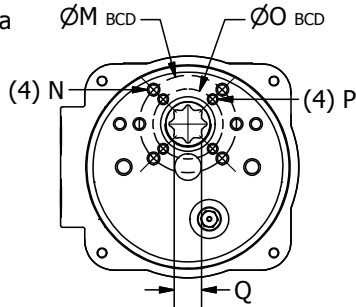
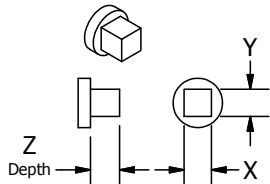

P1.A

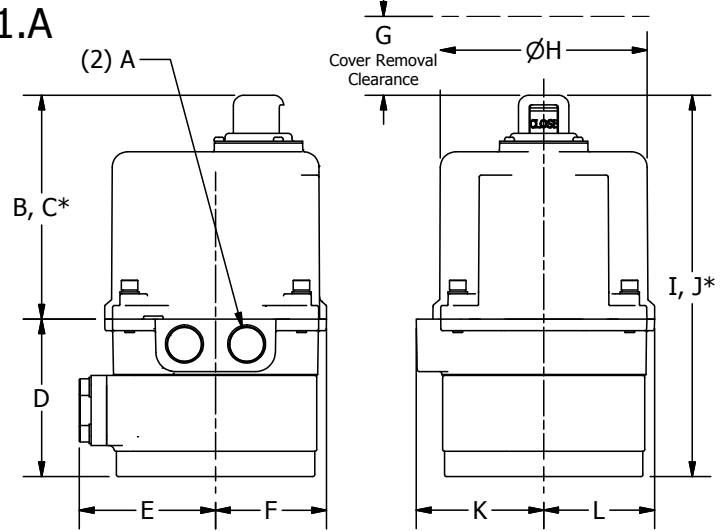

Drive Coupling Fabrication Data

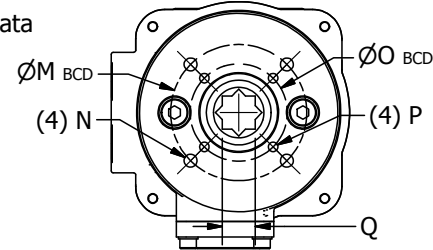
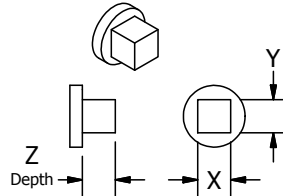

| Actuator | Torque (lb-in) | ISO 5211 Mount | Dimensions - in (mm) | | | | | | | | | | |
|----------------|----------------|----------------|----------------------|-----------|-----------|----------|----------|----------|-----------|-----------|-----------|-----------|----------|
| | | | A | B | C* | D | E | F | G | H | I | J* | K |
| PZ | 55-135 | F03/F05 | 3.3ft (1.0m) Cable | 3.2 (82) | 4.4 (113) | 1.7 (43) | 2.3 (60) | 1.0 (26) | 4.5 (114) | 3.0 (77) | 4.9 (125) | 6.1 (156) | 2.7 (69) |
| P1, P1.B, P1.C | 135-300 | F03/F05 | 1/2"-14 NPT | 4.5 (115) | 5.8 (148) | 1.4 (35) | 3.1 (79) | 1.4 (35) | 6.0 (152) | 4.2 (106) | 5.9 (150) | 7.2 (183) | 2.6 (66) |
| P1.A | 445 | F05/F07 | 1/2"-14 NPT | 4.5 (115) | 5.8 (148) | 3.2 (81) | 2.8 (70) | 2.2 (57) | 6.0 (152) | 4.2 (106) | 7.7 (196) | 9.0 (229) | 2.8 (70) |

| Actuator | Dimensions - in (mm) | | | | | | | | | | | | |
|----------------|----------------------|----------|----------------|----------|---------------|-----------|---------|-----------|-----------|-----------|---------------|---------------|---------------|
| | L | M | N | O | P | Q | R | S | T | U | X** | Y** | Z |
| PZ | 1.7 (42) | 2.0 (50) | M6-1.0 x 15mm | 1.4 (36) | M5-0.8 x 15mm | 0.55 (14) | 0.2 (4) | 4.4 (111) | 6.0 (152) | 7.0 (178) | 0.551 (14.00) | 0.551 (14.00) | 0.591 (15.00) |
| P1, P1.B, P1.C | 2.2 (57) | 2.0 (50) | M6-1.0 x 10mm | 1.4 (36) | M5-0.8 x 8mm | 0.55 (14) | 0.3 (8) | 0.3 (8) | 0.4 (11) | 1.9 (46) | 0.551 (14.00) | 0.551 (14.00) | 0.591 (15.00) |
| P1.A | 2.2 (57) | 2.8 (70) | M8-1.25 x 12mm | 2.0 (50) | M6-1.0 x 10mm | 0.67 (17) | 0.2 (5) | 1.3 (34) | 0.3 (7) | - | 0.669 (17.00) | 0.669 (17.00) | 0.669 (17.00) |

*Dimension for 24v PZ Actuators or Proportional P1, P1.A Actuators

**Tolerance +0.000 -0.005 (+0.00 -0.130)