



PROMATION ENGINEERING

Precision Actuation for Industry

24 Volt Low End Torque PZ-15, P1, P1.A, P1.B, and P1.C quarter-turn electric actuators

Get more work done with five ultra
compact or compact 24 volt actuators
spanning 3 torque ranges



**PZ15-24N4-AC Series
Actuator with linkage kit on
3/4" stainless steel ball valve**

For ball or butterfly valves or dampers
requiring 135 in lb through 445 in lbs
break torque.

Cam Controlled - Four total cams installed which may be set to any position in the 90 degree travel of the actuator. The two auxiliary cams have hot outputs which allow options for control programming or for control of external devices.

Precision SPDT Switches - Dry contact switches rated at 10A @ 250vac maximum.

24 volt Power* - PZ15~P1.C available for 24 volt installations.

- P1, P1.A, P1.B available in 24vac or vdc.
- PZ15 in 24vac only
- P1.C in 24vdc only.

All Metal Construction - Powder coated aluminum alloy enclosures rated NEMA4/4X.

External Indicators - P1, P1.A, P1.B, and P1.C all have easy to read visual indicators.

- PZ15 products have pilot output which can drive indicator lights or provide other functions.
- P1~P1.C products have pilot output AND optional hot outputs for lights or other functions.

* PZ15~P1.B actuators are also available in 120/230vac

Product Details

Available in bulk packs OR call for project pricing.



PZ Actual Height 4.9”
(Actuator only)



P1 Actual Height 5.9”
(Actuator only, On/Off)

SAMPLE DIAGRAMS

Refer to the proper IOM for your actuator for the correct wiring diagram or visit www.promation.com.

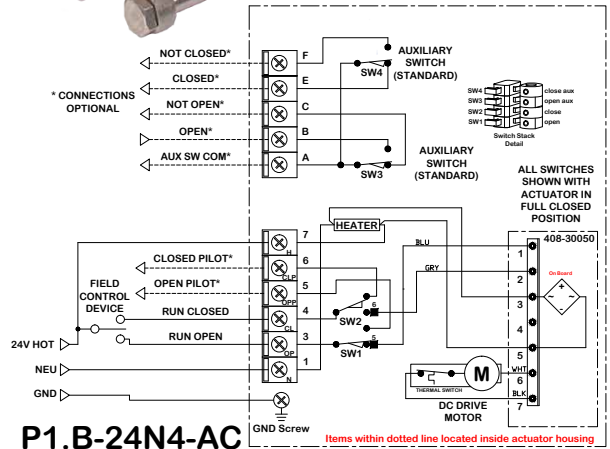
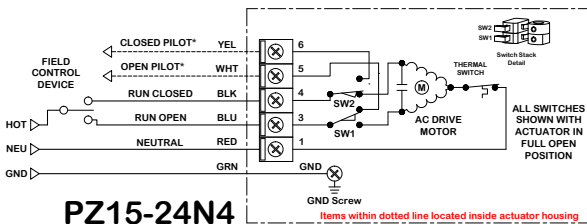

For Product Family	Torque (in lbs)	Speed (Sec for 90°)	Voltage	Max Inrush Current (60Hz)	Duty Cycle	Relative Cost
PZ15-24N4-AC	135	17	24vac	1.5A	25%	\$
P1-24N4-AC	300	15	24vac	1.1A	75%	\$\$\$
P1.A-24N4-AC	445	20	24vac	1.5A	75%	\$\$\$\$
P1.B-24N4-AC	135	8	24vac	1.1A	75%	\$\$\$
P1.C-24N4-DC	135	3	24vdc	5.4A (vdc)	75%	\$\$\$



16138 Flight Path Drive
Brooksville, FL 34604
Phone (352) 544-8436 Fax (352) 544-8439
email: sales@promationei.com



Use your smart phone barcode scanner app here.