



PROMATION ENGINEERING

Precision Actuation for Industry

Data Sheet

PBO Series

w/ Manual Override

ISO5211 F10 8P22

High Temperature Applications (-T59)

Standard, Monitor (-MTC) and Bypass (-BTC) Thermal Circuit Options

Actuator Specifications	PBO		
Torque "lb/Nm	1150"lbs/130Nm		
Supply Voltage	24vac/dc	120vac	230vac
Max Inrush Current	19.0A	11.0A	5.6A
Running Current	9.0A	3.8A	2.1A
Motor	DC Brush Type	Split Phase Capacitor	
Runtime (90°@60Hz/vdc)	8.0 sec	7.0 sec	
Runtime (90°@50Hz)	8.0 sec	9.0 sec	
Runtime (spring)	3.0 sec	8.0 sec	
Duty Cycle	50%		
Motor Starts	300 per hour		
Weight	184lbs / 84kg		
Mechanical Connections	ISO5211 F10 8pt 22mm		
Electrical Entry	(2) 3/4" NPT		
Electrical Terminations	12-16ga		
Environmental Rating	NEMA 4/4X		
Manual Override	11.6" Handwheel		
Control	On/Off	On/Off, Proportional	
Actuator Case material	Aluminum Alloy, Powder coated		
Motor Protection	230°F/110°C Thermal F* Class *Totally Enclosed Non-Ventilated Motors		
Ambient Temperature	-22°F to +149°F		
Operating Range	-30°C to +65°C		



This version has a manual override

ProMation Engineering SPRING RETURN electric actuators with the -T59 suffix are specifically designed for use in tunnel applications. They have been third party tested for use up to two hours at 250°C (482°F) with a thermal protection blanket and up to one hour at 150°C (302°F). The actuator comes standard with two auxiliary switches (Form C) and internal low power heater.

The standard version has a thermal protection circuit that interrupts power to the motor when the internal wiring temperature reaches 125°C. The motor resumes operation after the internal temperature drops below 115°C.

The -MTC configuration uses a form C thermo-switch to monitor the temperature and will change state from normally closed at 125°C returning to normally closed when the motor temperature drops below 115°C. The motor will not cease functioning at high temperatures. Catastrophic damage to the motor can then occur. Motors are not warranted in the -MTC configuration.

The -BTC configuration has a form C bypass circuit in parallel with the motor thermo-switch. When the bypass circuit is open, the motor thermal protection circuit is functional and interrupts power to the motor when the motor temperature reaches 125°C. The motor resumes operation after the internal temperature drops below 115°C. When the bypass circuit is closed, the motor thermal protection circuit is not functional and the motor will not cease functioning at high temperatures. Catastrophic damage to the motor can then occur. Motors are not warranted in the -BTC configuration.

Theory of Operation

While power is present, the actuator will respond to drive control signals depending on the model chosen.

A2 position (on/off) unit will drive until it reaches the full end of travel setting opposite the spring return direction.

A Proportional control unit will follow an analog control signal for positioning and will HOLD until a modified control signal is received.

In each of these models a motor brake unit is utilized to HOLD the actuator in position until commanded to move OR a loss of supply voltage.

If power is lost or removed at any time, the brake is released and the mechanical spring mechanism returns the actuator to its normal (unloaded) position. Once the spring mechanism has been released, the actuator will not drive under power again until all criteria are met:

- The unit has reached its fail stop (unloaded) position,
- Power has been restored to the actuator.
- Initial Power Startup time delay has elapsed



Not all versions of spring return actuators are CSA certified to CSA and UL standards

Application requirements will dictate whether to utilize a CW (clockwise spring return) or CCW (counter-clockwise spring return) model.

Spring return direction is NOT changeable and actuator must be configured for spring return direction at time of order.

* Duty cycle is affected by ambient temperature, supply voltage and control signal stability

PBO Series Dimensional Data

Spring Return Series Exploded View *(Override Unit, Typical)*

CAUTION! Internal Springs are under **EXTREME** compression and must **NOT** be altered or modified under any circumstances. **DO NOT REMOVE END CAP SCREWS.** Failure to comply with this warning could cause **severe bodily injury and voids any liability or warranty**

MISE EN GARDE! Les ressorts internes sont soumis à une compression **EXTRÊME** et ne doivent en aucun cas être modifiés ou modifiés. **N'ENLEVEZ PAS LES VIS DE CAPUCHON.** Le non-respect de cet avertissement peut causer des blessures corporelles graves et annule toute responsabilité ou garantie

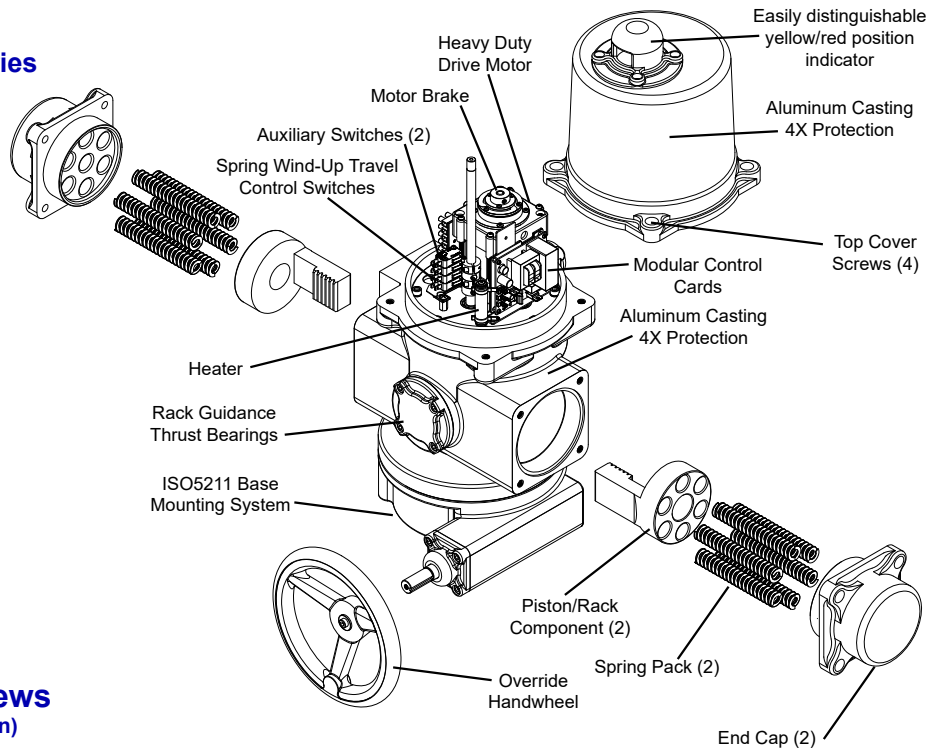

PBO Series Views *(CW Version shown)*

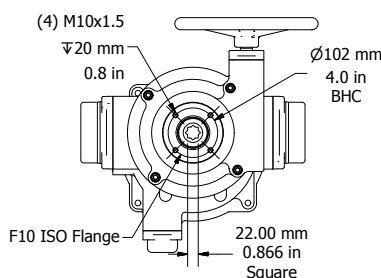
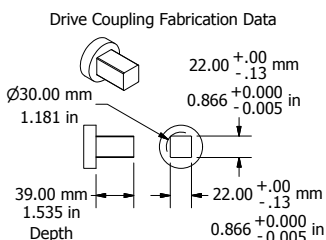
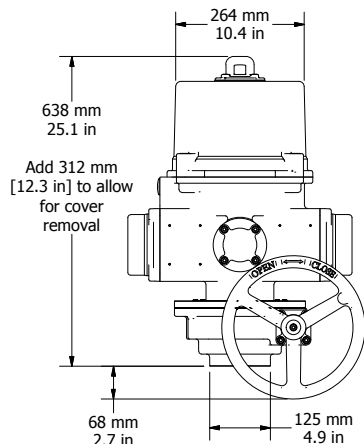
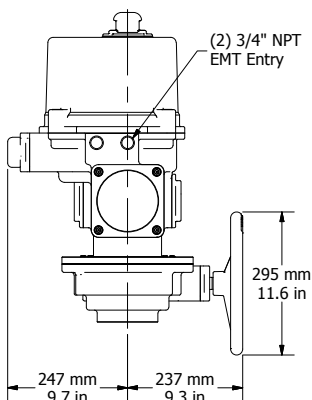
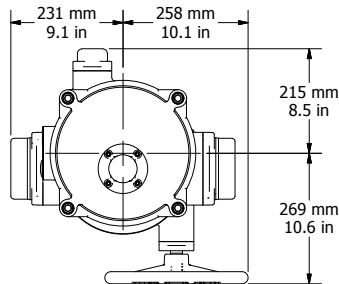
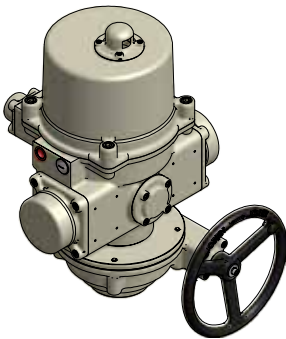

Application Notes:

1. These actuators are designed to be used between a horizontal or upright position. Do NOT mount the actuator with the top below a horizontal position.
2. When installing conduit, use proper techniques for entry into the actuator. Use drip loops to prevent conduit condensate from entering the actuator.
3. Both NPT conduit ports MUST use proper equipment to protect the NEMA 4X integrity of the housing.
4. The internal heater is to be used in ALL applications.
5. Do NOT install or store the actuator outdoors or in humid environments unless it is powered up and the heater is functioning.
6. Use proper wire size to prevent actuator failure (see chart below for proper wire sizing).
7. Mechanical travel stops are factory calibrated for 90 degree operation. These stops are NOT designed to adjust mechanical rotation by more than +/- 3 degrees.

Spring Pack Notes:

A modular cast aluminum housing incorporates the mechanical drive train, the spring pack and rack assemblies, the output drive shaft, motor and control section.

The spring pack is NOT field serviceable. Spring failure direction mode (CW or CCW) must be selected at time of order.

Wiring Diagrams for PBO Series

On/Off Control

Standard Configuration

On/Off (2 Position) control is used for damper or valve applications where the requirement is for either fully open or fully closed positioning.

This actuator must drive to its end of travel opposite the spring fail position. Loss of control signal or power before reaching its end of travel will cause the unit to spring return.

- Field Control Device may be relay contact, Switch or Triac type.
- Pilot device 10A MAX.
- Auxiliary switches are rated 10A @ 250vac MAX.
- Terminals A-F are dry type Form C.
- Terminals accept 12-16ga solid/stranded wire.

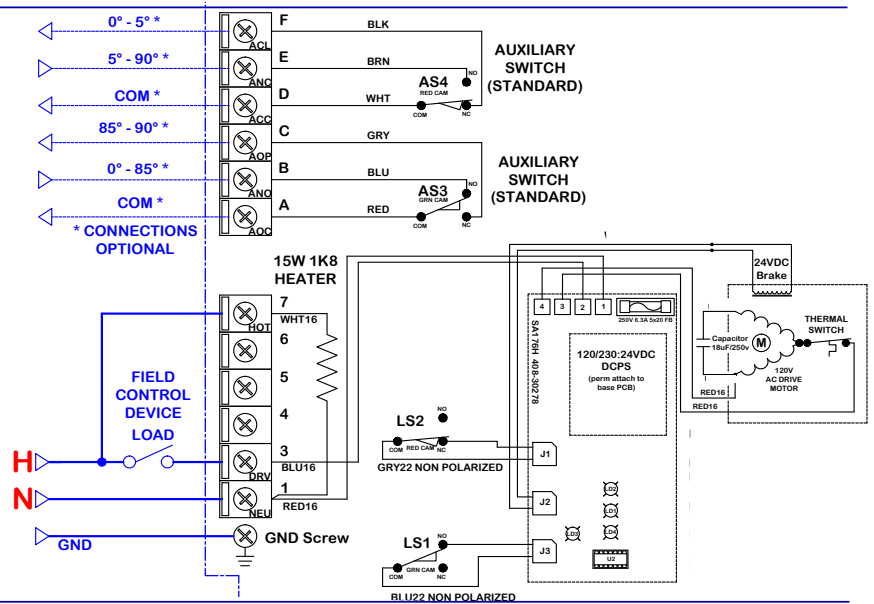

-MTC Configuration

Terminals 6 and 5 are dry type Form C contacts that monitor the motor temperature. The motor thermo-switch is normally closed and will change state to open at 125°C. The contact returns to closed when the motor temperature drops below 115°C. The motor will not cease functioning at high temperatures. Catastrophic damage to the motor can then occur.

Motors are not warranted in the -MTC configuration.

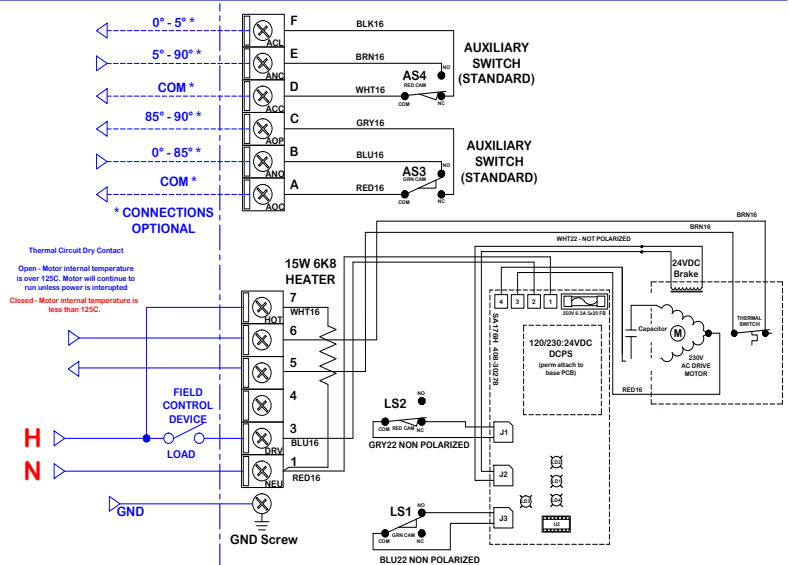

-BTC Configuration

Terminals 6 and 5 are dry type Form C contacts that are in parallel with the motor thermo-switch. When the bypass circuit is open, the motor thermal protection circuit is functional and interrupts power to the motor when the motor temperature reaches 125°C. The motor resumes operation after the internal temperature drops below 115°C. When the bypass circuit is closed, the motor thermal protection circuit is not functional and the motor will not cease functioning at high temperatures. Catastrophic damage to the motor can then occur.

Motors are not warranted in the -BTC configuration.

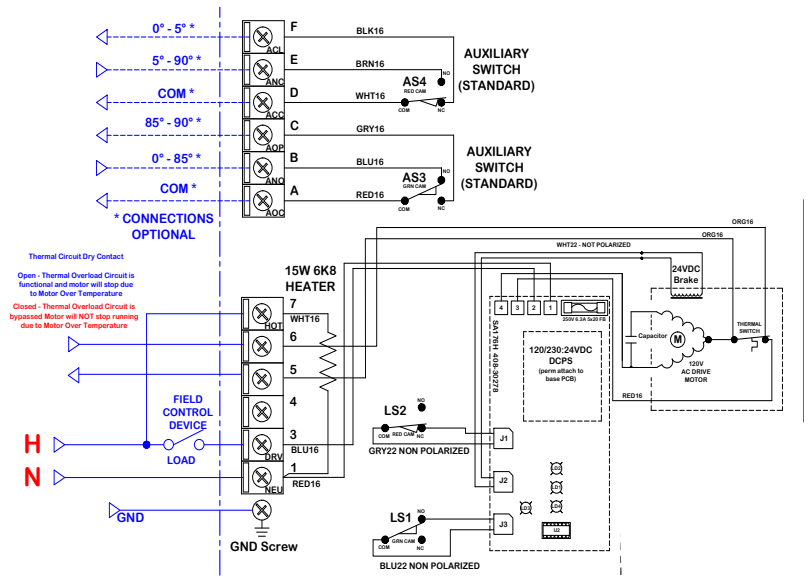

SD15_PADO-T59 Ver A_010318



Wire Sizing Chart

	MAX distance between Actuator and Supply (feet)		
Actuator/ Voltage	PBO 24VAC	PBO 120VAC	PBO 230VAC
Amps	19.0A	11.0A	5.6A
Wire Gage			
16	-	-	444
14	-	191	718
12	34	292	1098
10	57	496	1867
8	86	740	2786

Wire sizing data is provided in this table to assist in the selection of the proper wire size for ProMation Spring Return actuators using various wire sizes over distance.

Please make sure to reference the correct voltage and do not exceed the indicated length of the wire run for each model.

Motor thermal circuits do not impact wire sizing

Product Ordering Example:

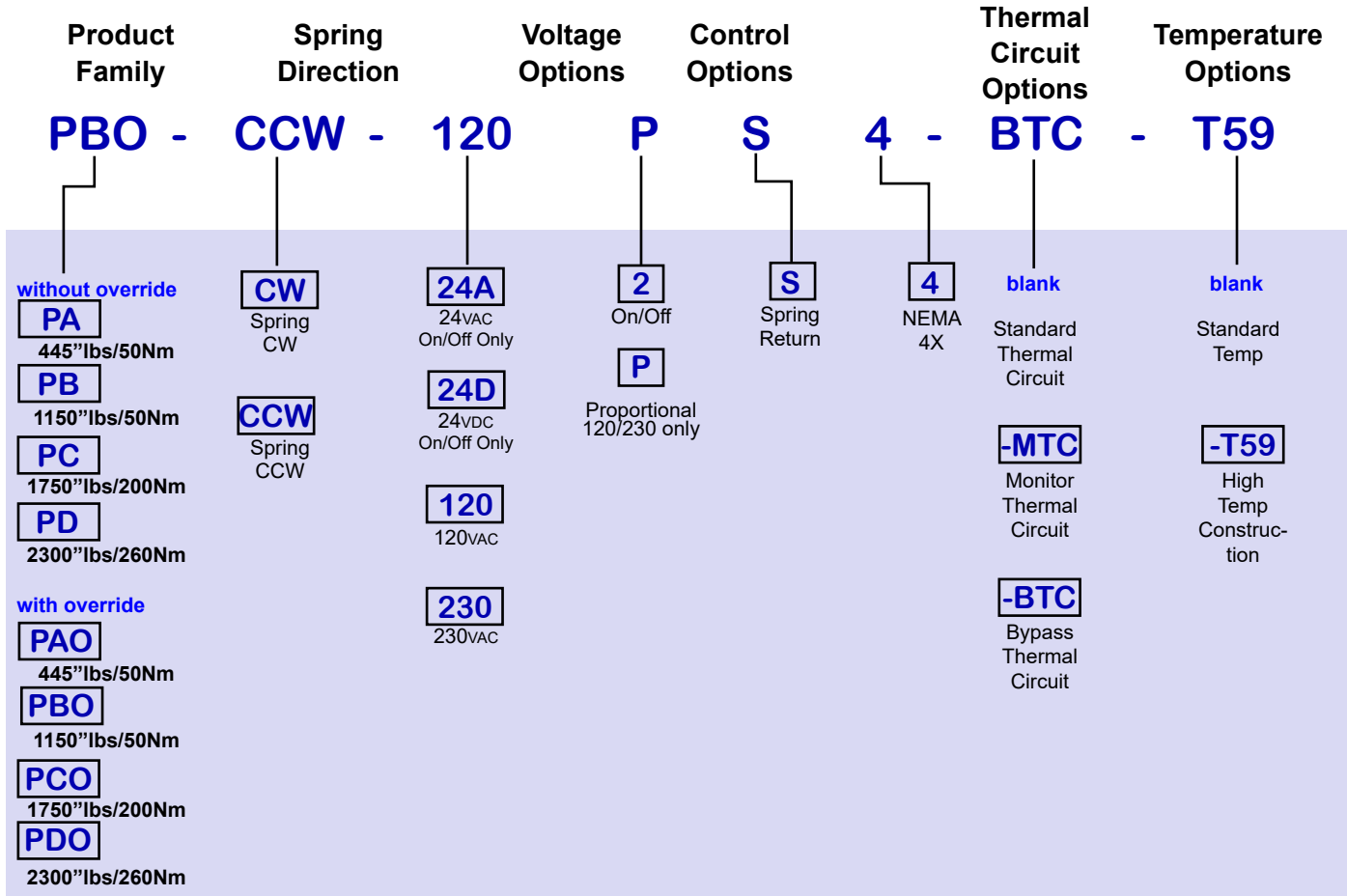

SD15_PADO_T59_Ver A_010318

ProMation Engineering follows a policy of continual product updates and enhancements. Our website is the best place to obtain the latest product documentation, including the wiring diagrams for these controllers. Visit us at www.promationei.com or use the QR code below to link to the site.



**PROMATION
ENGINEERING**
Precision Actuation for Industry

16138 Flight Path Drive
Brooksville, FL 34604
Phone (352) 544-8436 Fax (352) 544-8439
email: sales@promationei.com



Use your smart phone
barcode scanner app here.