



PROMATION ENGINEERING

Precision Actuation for Industry

Data Sheet

PDO Series w/ Manual Override ISO5211 F12 8P27

Actuator Specifications	PDO		
Torque "lb/Nm	2300"lbs/260Nm		
Supply Voltage	24vac/dc	120vac	230vac
Max Inrush Current	19.0A	11.0A	5.6A
Running Current	9.0A	3.8A	2.1A
Motor	DC Brush Type	Split Phase Capacitor	
Runtime (90°@60Hz/vdc)	17.0 sec	14.0 sec	
Runtime (90°@50Hz)	17.0 sec	17.0 sec	
Runtime (spring)	3.0 sec	12.0 sec	
Duty Cycle	50%		
Motor Starts	300 per hour		
Weight	297lbs / 135kg		
Mechanical Connections	ISO5211 F12 8pt 27mm		
Electrical Entry	(2) 3/4" NPT		
Electrical Terminations	12-16ga		
Environmental Rating	NEMA 4/4X		
Manual Override	297lbs / 135kg		
Control	On/Off	On/Off, Proportional	
Actuator Case material	Aluminum Alloy, Powder coated		
Motor Protection	230°F/110°C Thermal F* Class *Totally Enclosed Non-Ventilated Motors		
Ambient Temperature	-22°F to +149°F		
Operating Range	-30°C to +65°C		



This image shows a CW actuator.

A SPRING RETURN electric actuator designed for load requirements up to **2300"lbs**. The actuator comes standard with two auxiliary switches (Form C), an internal low power heater, a NEMA 4X environmental rating, and in 120/230VAC or 24VAC/DC (On/Off only) supply voltages. The PDO Series mechanical connections utilize an ISO5211 mounting system, size F12 with an 8 point 27 mm female drive. The PDO Series is offered in two different control modes....On/Off (2 position control), or Proportional (modulating control).

Application requirements will dictate whether to utilize a CW (clockwise spring return) or CCW (counter-clockwise spring return) model.

Spring return direction is NOT changeable and actuator must be configured for spring return direction at time of order.

Theory of Operation

While power is present, the actuator will respond to drive control signals depending on the model chosen.

A 2 position unit will drive until it reaches the full end of travel setting opposite the spring return direction.

A Proportional control unit will follow an analog control signal for positioning and will HOLD until a modified control signal is received.

In each of these models a motor brake unit is utilized to HOLD the actuator in position until commanded to move OR a loss of supply voltage.

If power is lost or removed at any time, the brake is released and the mechanical spring mechanism returns the actuator to its normal (unloaded) position. Once the spring mechanism has been released, the actuator will not drive under power again until all criteria are met:

- The unit has reached its fail stop (unloaded) position,
- Power has been restored to the actuator.
- Initial Power Startup time delay has elapsed



• Duty cycle is defined as the ratio of run time vs. off time, and is a function of environmental conditions including ambient temperature, supply voltage and control signal stability

* **24V units On/Off Only**

** **3 phase solutions use a single phase transformer in a local control station to power the actuator.**

S2600-110-T(M) S2600-24A-T
S2600-220-T(M) S2600-24D-T

PDO Series Dimensional Data

Spring Return Series Exploded View

(Override Unit, Typical)

CAUTION! Internal Springs are under **EXTREME** compression and must **NOT** be altered or modified under any circumstances. **DO NOT REMOVE END CAP SCREWS.** Failure to comply with this warning could cause **severe bodily injury and voids any liability or warranty**

MISE EN GARDE! Les ressorts internes sont soumis à une compression **EXTRÊME** et ne doivent en aucun cas être modifiés ou modifiés. **N'ENLEVEZ PAS LES VIS DE CAPUCHON.** Le non-respect de cet avertissement peut causer des blessures corporelles graves et annule toute responsabilité ou garantie

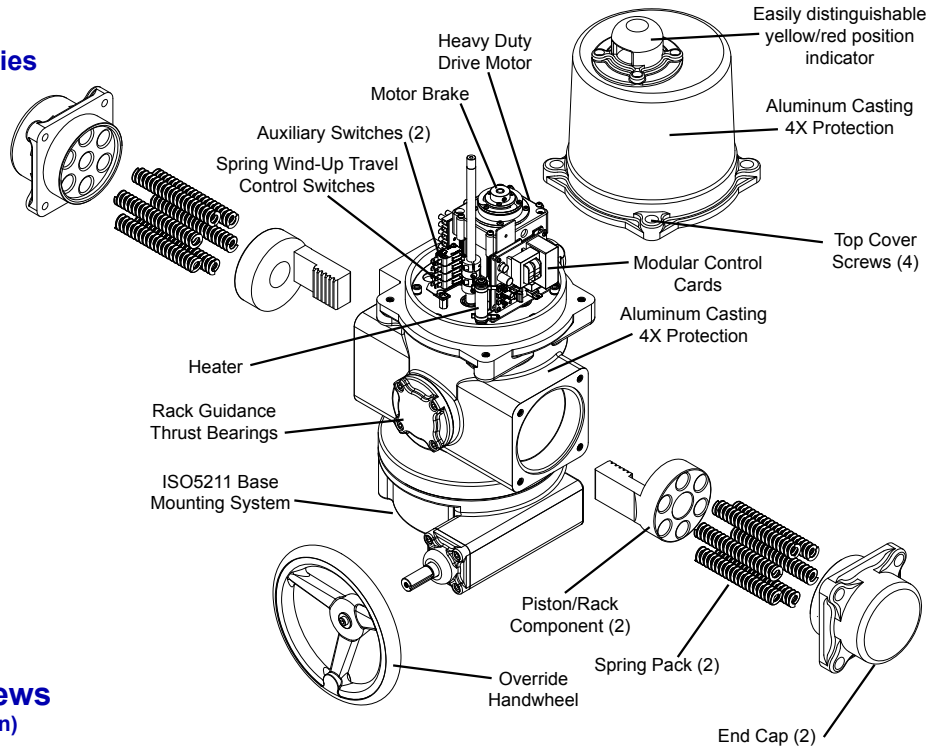

PDO Series Views

(CW Version shown)

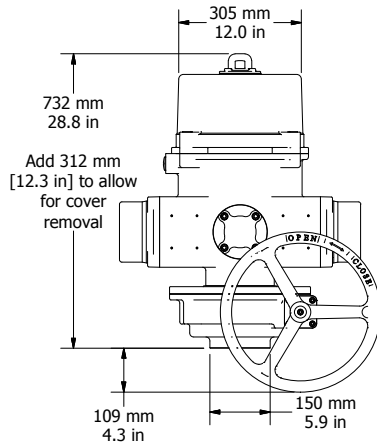
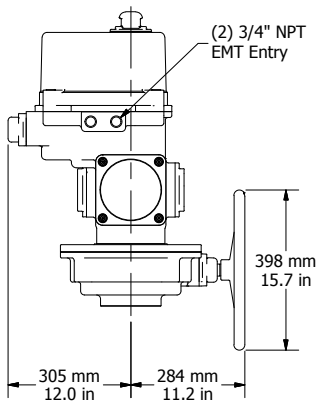
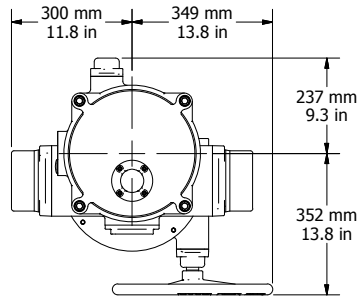
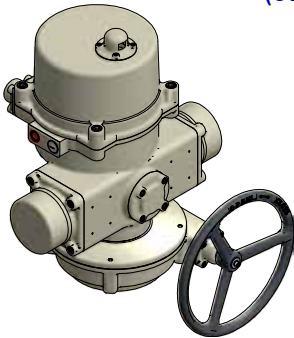

Application Notes:

1. These actuators are designed to be used between a horizontal or upright position. Do NOT mount the actuator with the top below a horizontal position.
2. When installing conduit, use proper techniques for entry into the actuator. Use drip loops to prevent conduit condensate from entering the actuator.
3. Both NPT conduit ports MUST use proper equipment to protect the NEMA 4X integrity of the housing.
4. The internal heater is to be used in ALL applications.
5. Do NOT install or store the actuator outdoors or in humid environments unless it is powered up and the heater is functioning.
6. Use proper wire size to prevent actuator failure (see chart below for proper wire sizing).
7. Mechanical travel stops are factory calibrated for 90 degree operation. These stops are NOT designed to adjust mechanical rotation by more than +/- 3 degrees.

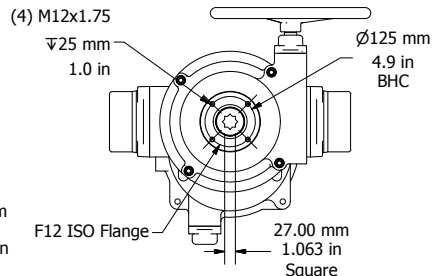
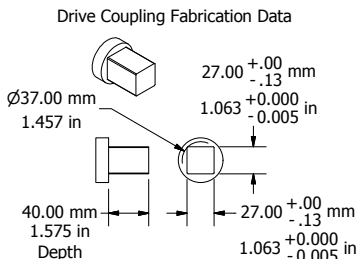

Spring Pack Notes:

A modular cast aluminum housing incorporates the mechanical drive train, the spring pack and rack assemblies, the output drive shaft, motor and control section.

The spring pack is NOT field serviceable. Spring failure direction mode (CW or CCW) must be selected at time of order.

On/Off (2 Position Control)

On/Off (2 Position) control is used for damper or valve applications where the requirement is for either fully open or fully closed positioning.

This actuator must drive to its end of travel opposite the spring fail position. Loss of control signal or power before reaching its end of travel will cause the unit to spring return.

- Field Control Device may be relay contact, Switch or Triac type.
- Pilot device 10A MAX.
- Auxiliary switches are rated 10A @ 250vac MAX.
- Terminals A-F are dry type Form C.
- Terminals accept 12-16ga solid/stranded wire.

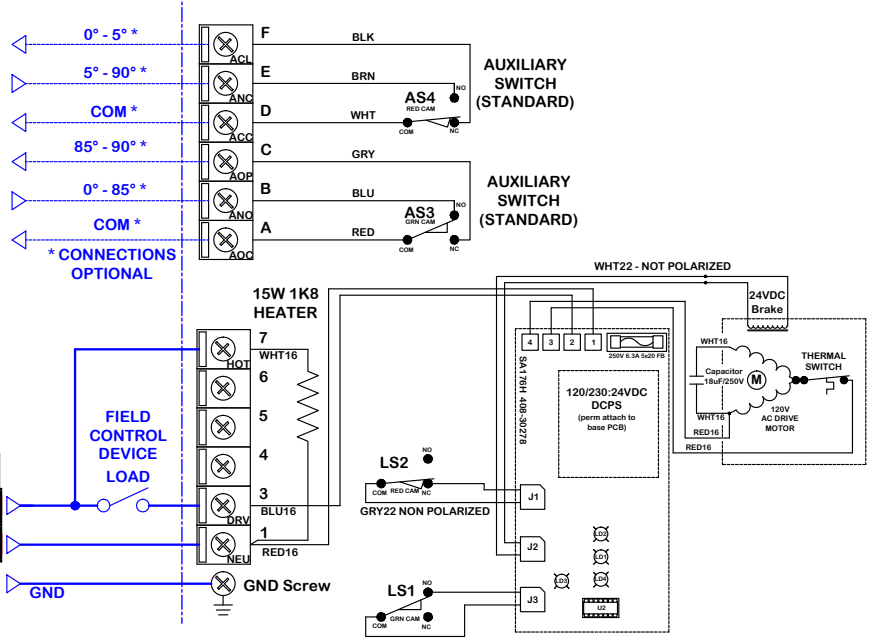

Wire Sizing Chart

		MAX distance between Actuator and Supply (feet)		
		PDO 24VAC	PDO 120VAC	PDO 230VAC
Actuator/ Voltage	Amps	19.0A	11.0A	5.6A
	Wire Gage			
16		-	-	444
14		-	191	718
12		34	292	1098
10		57	496	1867
8		86	740	2786

Wire sizing data is provided in this table to assist in the selection of the proper wire size for ProMation PA-PDO series actuators using various wire sizes over distance. Please make sure to reference the correct voltage and do not exceed the indicated length of the wire run for each model.

Proportional Control

Proportional Control

Proportional control is used for damper or valve applications where the requirement is for the device to follow an analog control signal to provide modulating control of the device.

The unit will accept various control signal inputs (4-20mA, 2-10vdc or 1-5vdc) and also will provide an analog feedback signal for external signal referencing. In this scheme, the motor brake will engage any time the drive motor is NOT moving under power.

Only a loss of supply POWER will cause the spring mechanism to fail-position the actuator. However, a loss of control SIGNAL can be programmed to drive the actuator to either fully open, fully closed or to fail-in-position.

Proportional Control available for 120/230vac applications only.

120VAC	230VAC
Hot	L1
Neu	L2
GND	GND

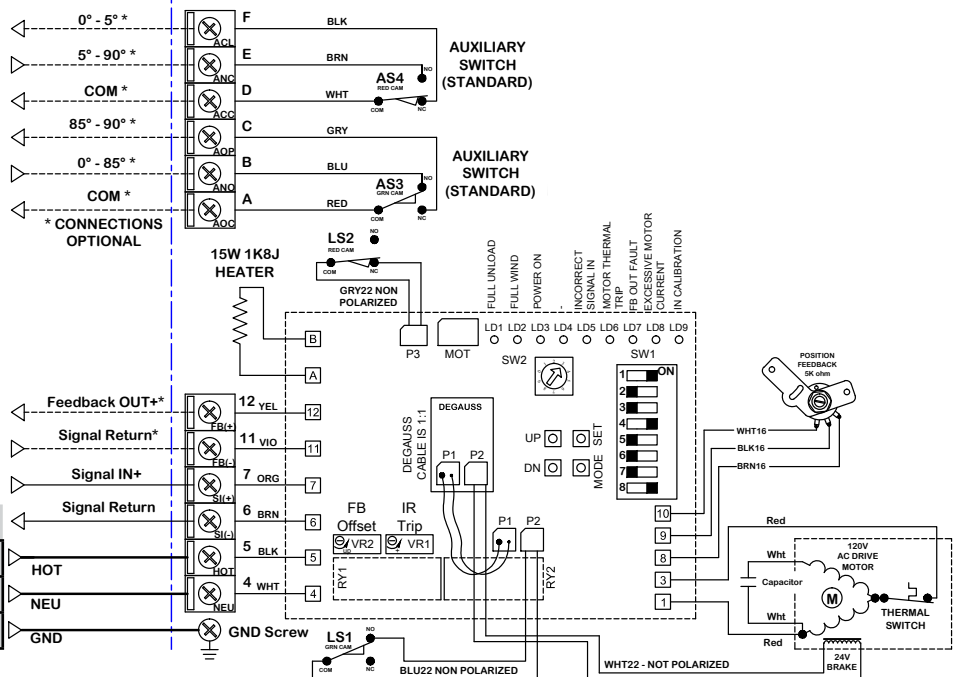

SAMPLE DIAGRAMS

Refer to the proper IOM for your actuator for the correct wiring diagram or visit www.promationei.com.

SD15_PADO Ver Q_111517

AVAILABLE OPTIONS (Factory Installed)

- Premium Proportional Controller Kit. Converts 2 position to proportional control.
- Cold weather auxiliary heater kit. Thermostatically controlled, On 32°F, Off at 50°F, auto reset, hermetically sealed, 24/120/230vac On/Off/Jog type actuators.
- Local Control Station offers “HAND/OFF/AUTO” Switch and OPEN/OFF/CLOSE Switch, No Indicator Lights. (See catalog for additional Local Control Stations)
- Local Control Stations (LCS) are designed to be remotely located or directly mounted to the actuator. Proportional actuators will have different options than On/Off. Available in steel, stainless, or fiberglass enclosures. (See catalog for additional Local Control Selections)
- 3 Phase models utilizing a Local Control Station housing a transformer which supplies single phase power to the actuator.

Product Ordering Example:

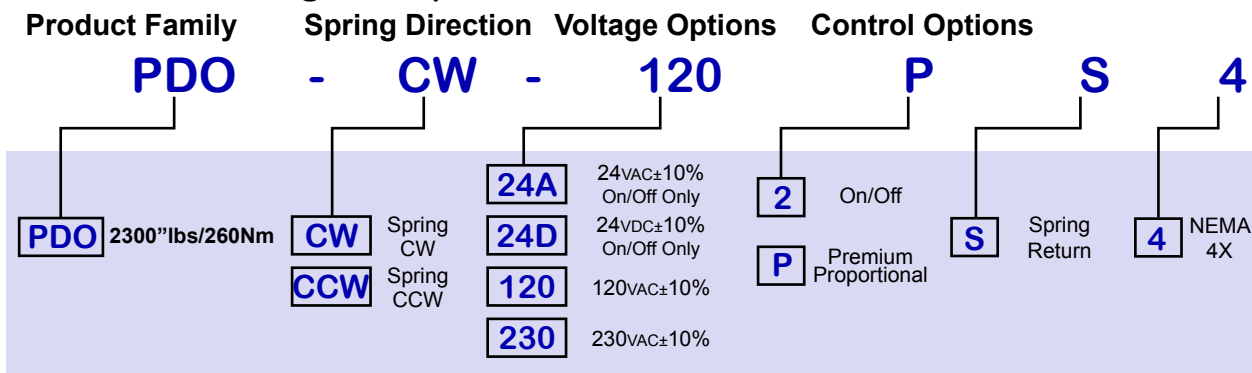

ProMation Product Line



**PL Series
Linear Drive**

Up to 4400lbs down/up force and up to 100mm (4”) stem travel

For globe valves, gate valves and linear travel devices. With override handwheel. Available with On/Off/Jog or Proportional control for 24vac, 24vdc, 120vac & 230vac supplies.



**P Series
Non-Spring Return**

55”lbs through 40,000”lbs. Quarter-Turn, with Manual Override

Available with On/Off/Jog or Proportional control. For 12vac/dc, 24vac/dc, 120vac, 230vac, 230v/3 phase, 380v/3 phase & 460v/3phase supplies.



**PA~PD Series
Spring Return**

445”lbs through 2300”lbs. Quarter-Turn, both with and w/o manual override handwheel.

Spring either CW or CCW. Available with On/Off control for 24vac/dc and On/Off or Proportional control for 120vac & 230vac supplies. Stepdown for 3phase available.



**PBU Battery
Back-Up Systems**

Provides power sufficient to drive P Series actuators to field-selectable fail-safe positions. For P Series & PL Series actuators in On/Off and Proportional control modes. Available for 24/120/230vac actuators. 120vac/230 vac supply.

SD15_PADO Ver Q_111517

ProMation Engineering follows a policy of continual product updates and enhancements. Our website is the best place to obtain the latest product documentation, including the wiring diagrams for these controllers. Visit us at www.promationei.com or use the QR code below to link to the site.



**PROMATION
ENGINEERING**
Precision Actuation for Industry

16138 Flight Path Drive
Brooksville, FL 34604
Phone (352) 544-8436 Fax (352) 544-8439
email: sales@promationei.com



Use your smart phone barcode scanner app here.