

name		dwn by:		Date		material no		ind		Wiring Diagram	
name		Date		Date		material		material		material	
rev change		revision		scale		NONE		NONE		NONE	
rev change		revision		scale		NONE		NONE		NONE	
rev change		revision		scale		NONE		NONE		NONE	
rev change		revision		scale		NONE		NONE		NONE	
rev change		revision		scale		NONE		NONE		NONE	
rev change		revision		scale		NONE		NONE		NONE	
rev change		revision		scale		NONE		NONE		NONE	
rev change		revision		scale		NONE		NONE		NONE	
rev change		revision		scale		NONE		NONE		NONE	
rev change		revision		scale		NONE		NONE		NONE	

Promotion

WD-850-A5A03 A

Use For:

Thermal Circuit Dry Contact

Open - Motor internal temperature is over 125C. Motor will continue to run unless power is interrupted

Closed - Motor internal temperature is less than 125C.

LINE IN 230VAC potential between L1 and L2

FIELD WIRING

INTERNAL ACTUATOR WIRING

OPEN showing in indicator window = FULLY LOADED (CCW)

CLOSED showing in indicator window = FULL SPRING RTN (CW)

Actuator ships in the fully UNLOADED (CW) position!

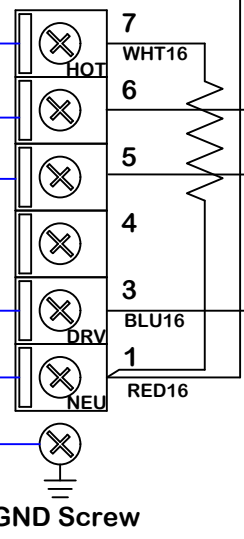
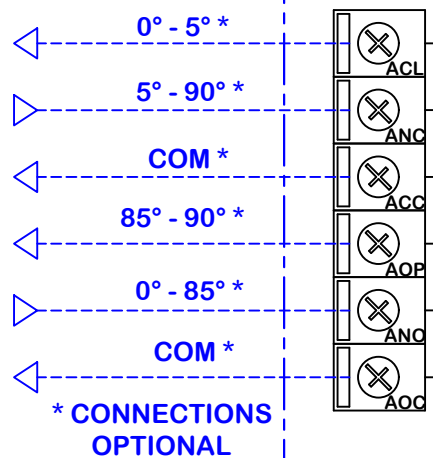

AUXILIARY SWITCH (STANDARD)

AUXILIARY SWITCH (STANDARD)

