

h	.	noming							
g			dwn by:	Date					
f			PMR	8.12.2019					
e									
d									
c									
b									
a									
Change date	09.25.2013	revision	New Document						
rev			PMR						
08.12.19		ProMation		WD-850-AD8A01.dwg		On/Off wiring diagram for 480vac 3Ph PA-PD(O) Series CW Spring Return Actuators		REV <b>A</b>	
Scale		NONE		Material no		Wiring Diagram			

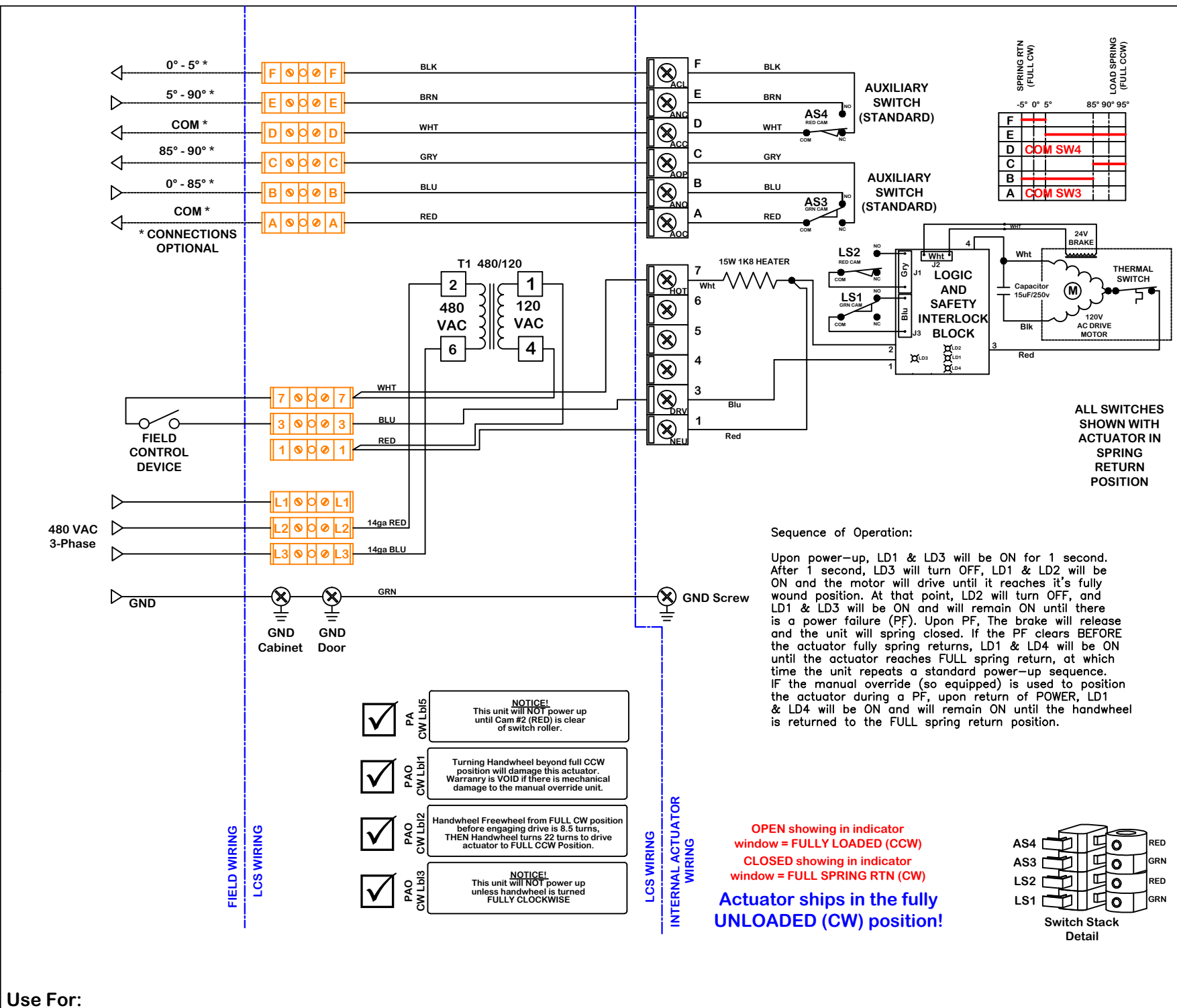

Use For: **PA/PD(O)-CW-4832S4**

This document is the property of ProMation Engineering, Inc. Distribution of this document without the written consent of the owner is strictly forbidden. Failure to comply will incur a liability for damages.