

rev change date	revision	name
f 08.23.12	Formattung edits	KHL
g 10.23.14	Added response board and cam to board stack	KHL
h 09.09.15	120V and 24VDC Spring Return Actuators	TJM
i 11.20.15	120V and 24VDC Spring Return Actuators	TJM
j 03.26.16	Final Rev. No. per ILS1, ILS2, ILS3, ILS4	TJM
k		
l		
m		

dwg by:	Date
BJW	4.19.2012
scale	
NONE	

3/28/2016 4:59 PM	WD-850-D4A01.dwg
On/Off wiring diagram for 120vac PC(O) Series CW Spring Return Actuators.	
REV	J

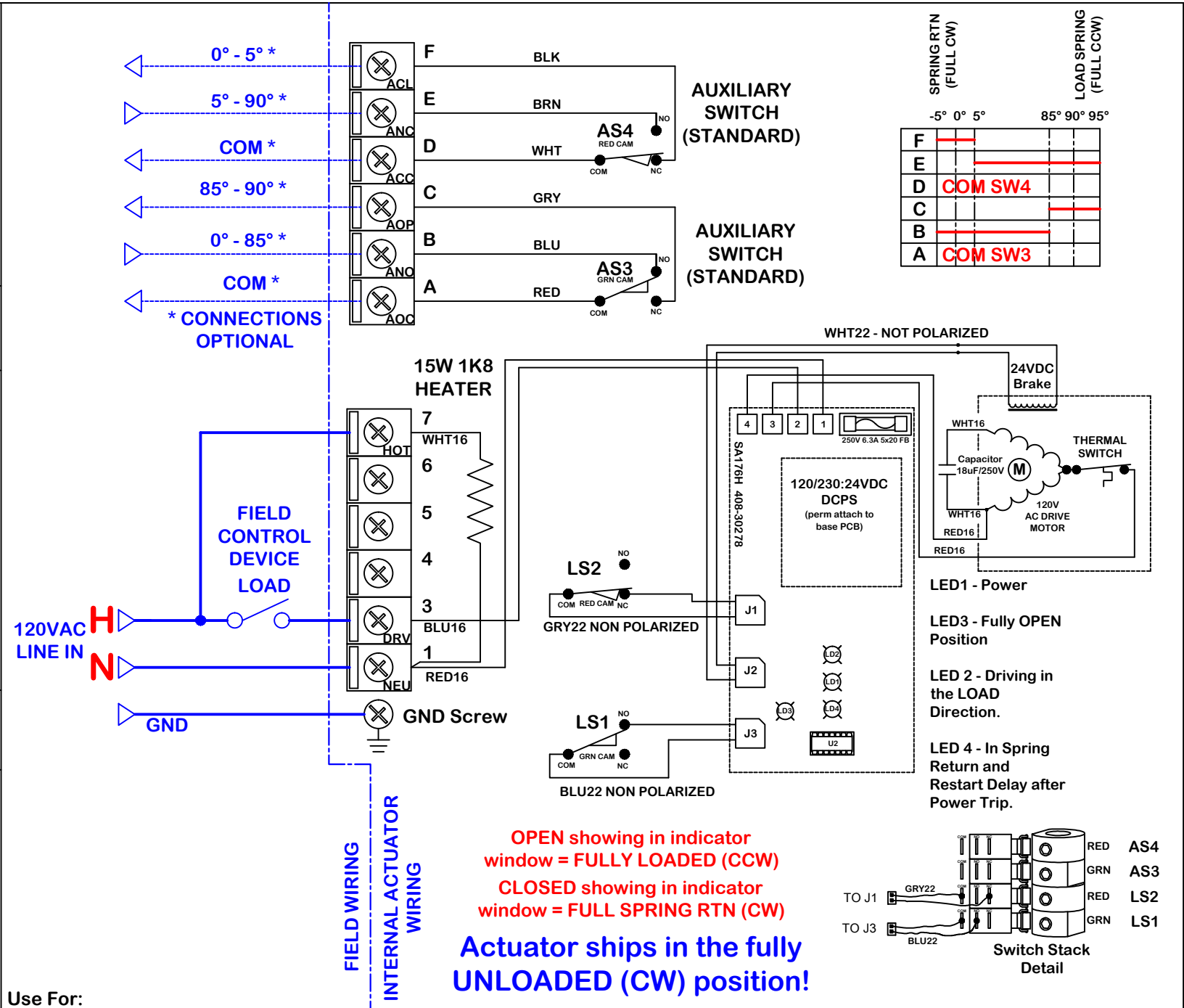

ProMation Engineering, Inc.  
16138 Flight Path Drive  
Brooksville, FL 34604  
Ph:352-544-8436 Fx(352-544-8439

This document is the property of ProMation Engineering, Inc.  
Distribution of this document without the written consent of the owner is strictly forbidden.  
Failure to comply will incur a liability for damages.