

rev	change	date	08/24/12	Forming and detail date	nom	2/14/2019 3:51 PM	WD 875 LB P1 24D D.dwg
c							
d							
e							
f							
g							
h							
i							
j							
naming							
material no							
ind							
Wiring Diagram							
material							
scale			NONE				
dwn by:			PMR				
Date			11.10.2011				
REV			A				
Wiring Diagram for Local Control Station			WD 875 LB P1 24D D				
P1-P1.A Series 24VDC Actuators							
ProMation							

**Description of Operation:**  
 Local / Remote On/Off/Jog control  
 EOT HOT outputs as well as EOT indicator lights.

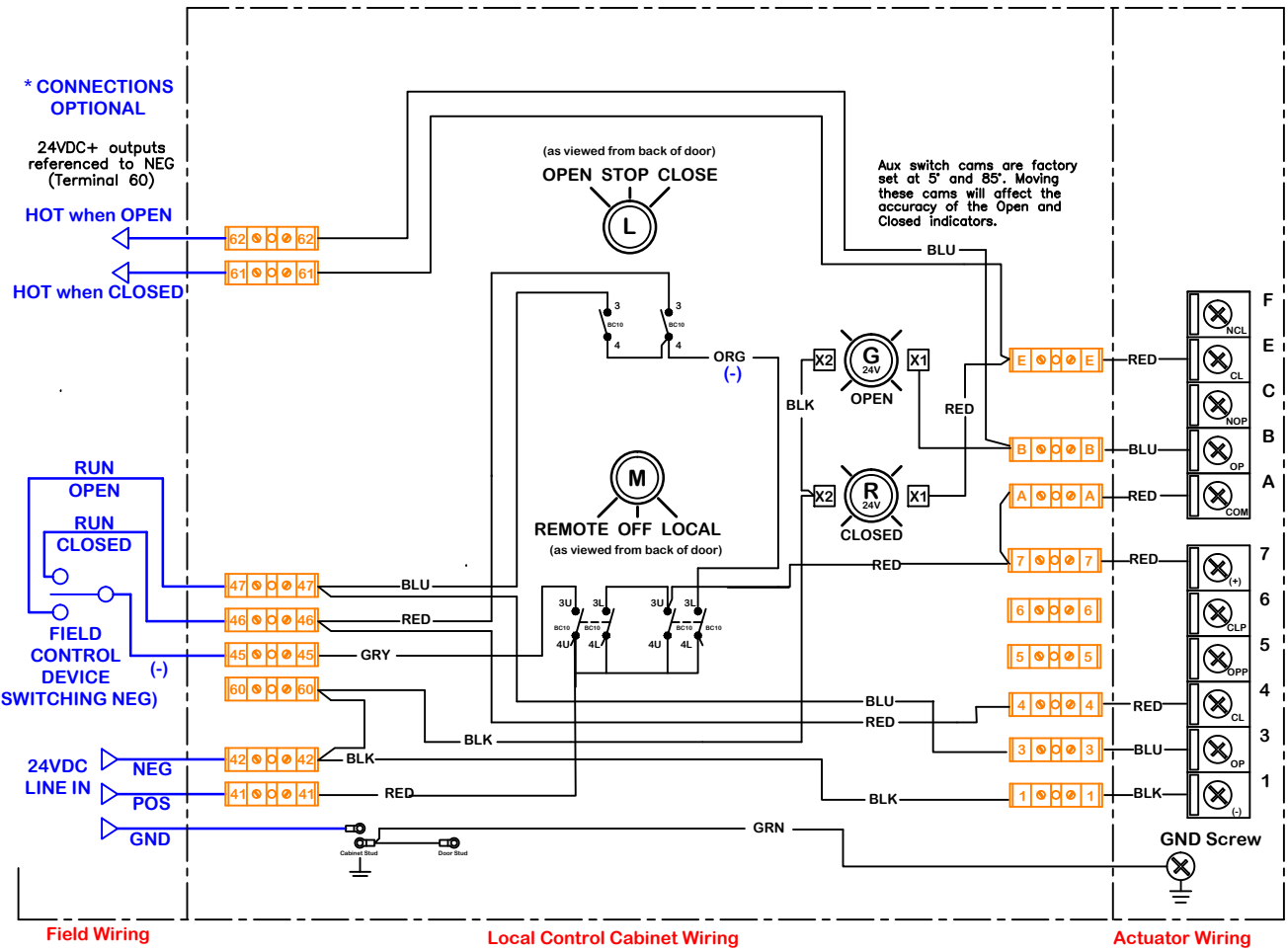

Use For:  
**OPT LCS LB P1 P/S/F 24D D/R**

ProMation Engineering, Inc.  
 16138 Flight Path Drive  
 Brooksville, FL 34604  
 Ph:352-544-8436 Fx(352-544-8439)

This document is the property of ProMation Engineering, Inc.  
 Distribution of this document without the written consent of the owner is strictly forbidden.  
 Failure to comply will incur a liability for damages.