

rev	change	date	description	rev	change	date	description
d	08/24/12		Forming end detail add				
e							
f							
g							
h							
i							
j							
k							
naming				material no			
part no				ind			
drawing				wiring diagram			
dwg by: BJW				date: 11.10.2011			
scale: NONE				material no			
9/18/2012 1009 AM				WD 875 LD 01 120 D.dwg			
Promotion				Wiring Diagram for Local Control Station			
WD 875 LD 01 120 D				P1 Series 120VAC Actuators			
REV D				Use For:			
ProMotion Engineering, Inc. 16138 Flight Path Drive Brooksville, FL 34604 Ph:352-544-8436 Fx(352-544-8439				OPT LCS LD 01 P/S/F 120 D/R			

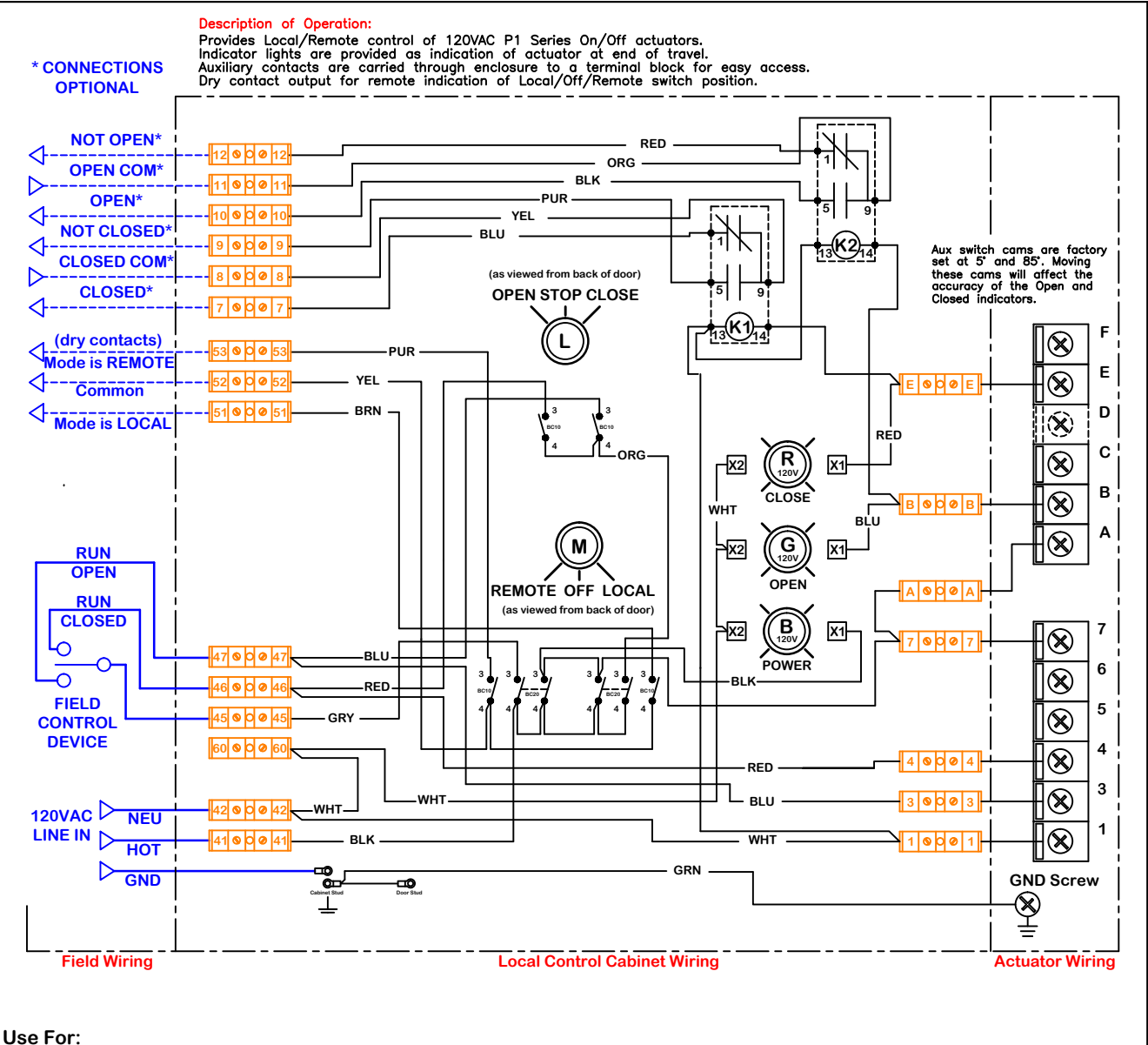

**Term Block**  
 Filename: Altech 875 LD01120D  
 Faceplate  
 Filename: 5 hole 5x5 Steel

**Enclosure front & back hole patterns**

**Door Hole Pattern**      **Back Hole Pattern**

**Notes:**

**Use this solution for:  
 P1 & PL Series**

This document is the property of ProMotion Engineering, Inc. Distribution of this document without the written consent of the owner is strictly forbidden. Failure to comply will incur a liability for damages.