

rev	C	d	e	f	g	h	i	j	noming
change date	09.03.2015								
revision	New Document								
name	KHL								
date	12/11/2017 8:27 AM								
scale	NONE								
material no	WD 875 LK 213-120-Menc								
ind									
material									
REV	F								

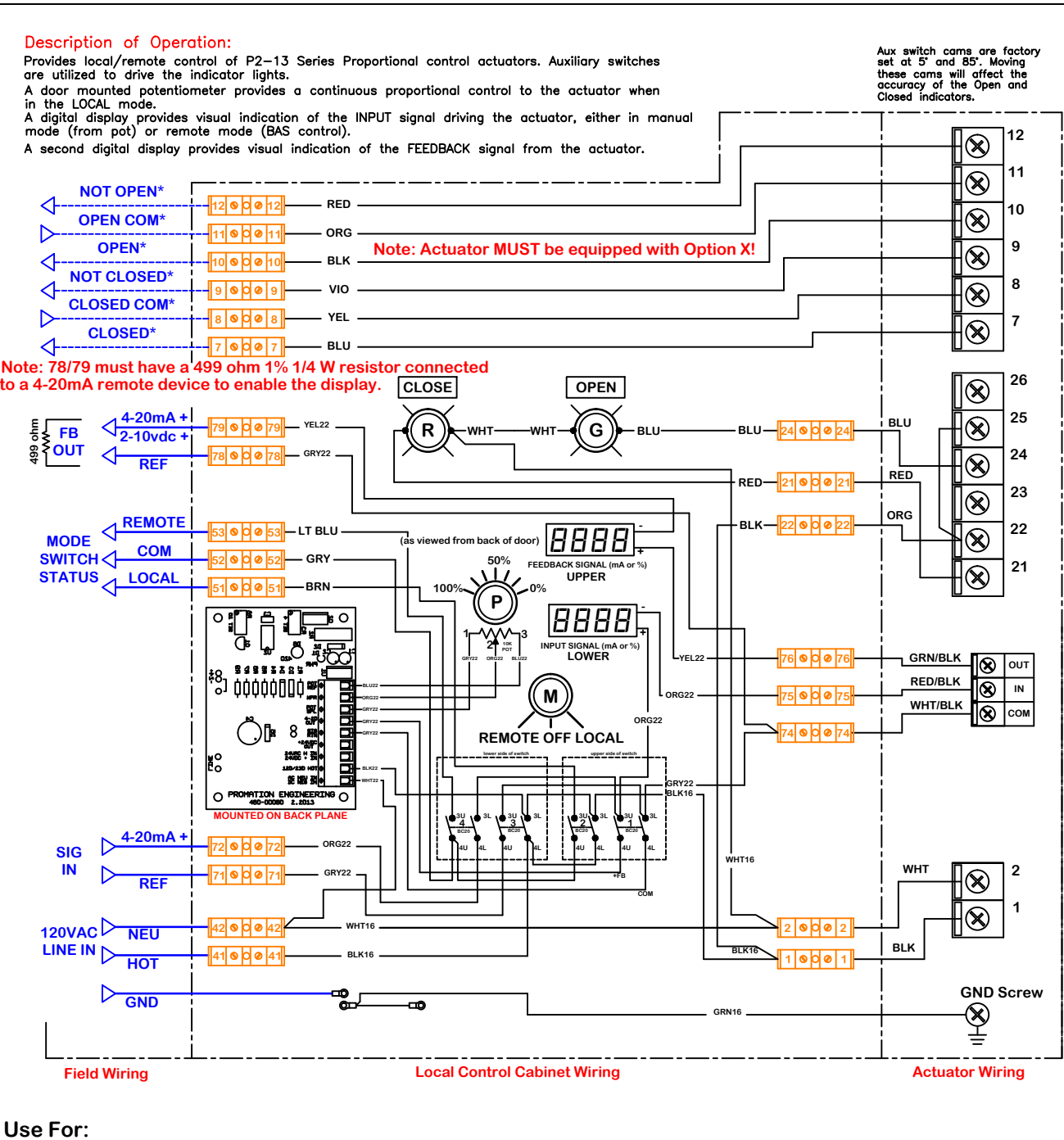

Term Block Filename: Altech 875 LK213P120D

FacePlate Filename: 4 hole 5x7 dual display Steel mA, 4 hole 5x7 dual display Steel mA, See Sales Order

Door Hole Pattern Back Hole Pattern Enclosure front & back hole patterns

Notes: THIS IS AN 8X6X6 ENCLOSURE!

Specify Control:

4-20mA Control

2-10vdc Control

Specify Display

mA or VDC

%

Use this solution for:

P2~13 Series

Use LJ for:

P1, PA & PL Series

Use For: **OPT LCS LK 213 P/S/F 120 D/R**

This document is the property of ProMotion Engineering, Inc. Distribution of this document without the written consent of the owner is strictly forbidden. Failure to comply will incur a liability for damages.