



PROMATION ENGINEERING

Precision Actuation for Industry

Data Sheet

P4/5/6 HV AC Series

On/Off/Jog/Proportional
ISO5211 F10 F12 8P36

Actuator Specifications	P4		P5		P6	
Torque "lb/Nm	3500"lbs/400Nm		4400"lbs/500Nm		5750"lbs/650Nm	
Supply Voltage	120vac	230vac	120vac	230vac	120vac	230vac
Max Inrush Current	7.0A	4.0A	7.0A	4.0A	7.0A	4.0A
Running Current	2.1A	1.1A	2.0A	1.0A	2.4A	1.1A
Motor	Split Phase Capacitor					
Runtime (90°@60Hz/vdc)	19 sec	20 sec	26 sec	26 sec	34 sec	34 sec
Duty Cycle	30%					
Motor Starts	1200 per hour					
Weight	47lbs/22kg (54lbs/24.5kg w/ -TS)					
Mechanical Connections	ISO F10 F12 36mm / Imp 3.25 5in BHC 1.125 in Shaft					
Electrical Entry	(2) ISO 3/4" / Imp 1/2" NPT					
Electrical Terminations	12-16ga					
Environmental Rating	NEMA 4/4X/IP67					
Manual Override	7.6" Handwheel					
Control	On/Off/Jog					
Actuator Case Material	Aluminum Alloy, Powder coated					
Motor Protection	230°F/110°C Thermal F* Class *Totally Enclosed Non-Ventilated Motors					
Ambient Temperature Operating Range	-22°F to +125°F -30°C to +52°C					

Also available in 12VAC/DC or 24VAC/DC or 3 phase supply. Separate spec sheets are available for these configurations.

See www.promationei.com for more information or call ProMation Engineering.



Electric actuators designed for load requirements ranging from **3500"lbs** up to **5750"lbs**. Each actuator comes standard with two auxiliary switches (Form C), an internal low power heater, a NEMA 4X environmental rating, and in 120vac and 230vac supply voltages. The P4/5/6 mechanical connections are ISO5211 compliant. The P4/5/6 Series can be ordered as an on/off (two position) model that can be used in bump/jog applications as well. Models can also be ordered with an internal proportional control card that accepts a wide range of control signals and generates multiple feedback signals for field use.

SD_P213_HV VerR 100Z25

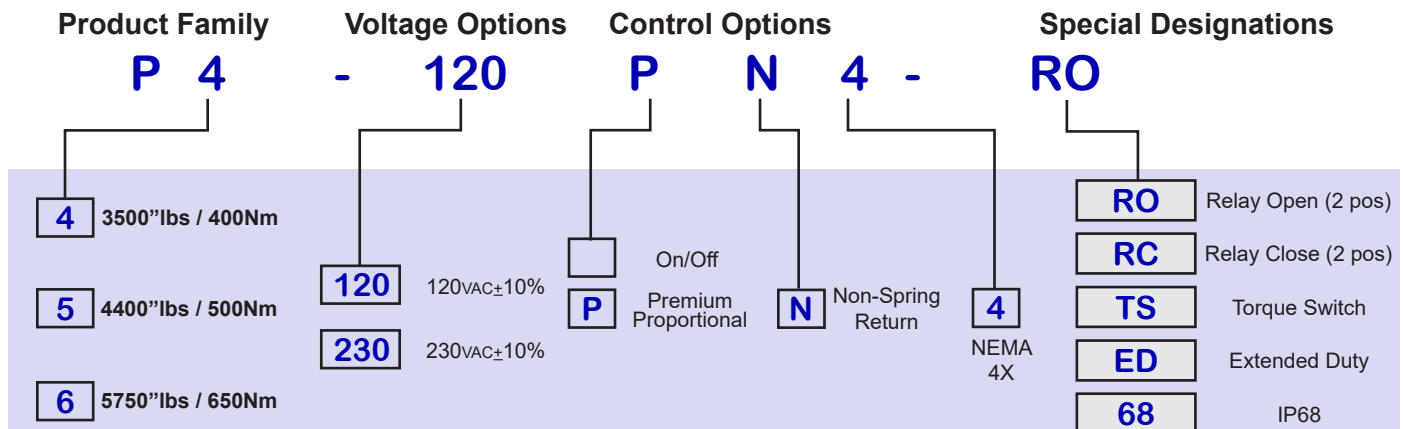

Note: Not all combinations are possible. Please consult factory.

P4/5/6 Series Dimensional Data

P4/5/6 Series Views

(Typical)

P Series Exploded View

(Typical)

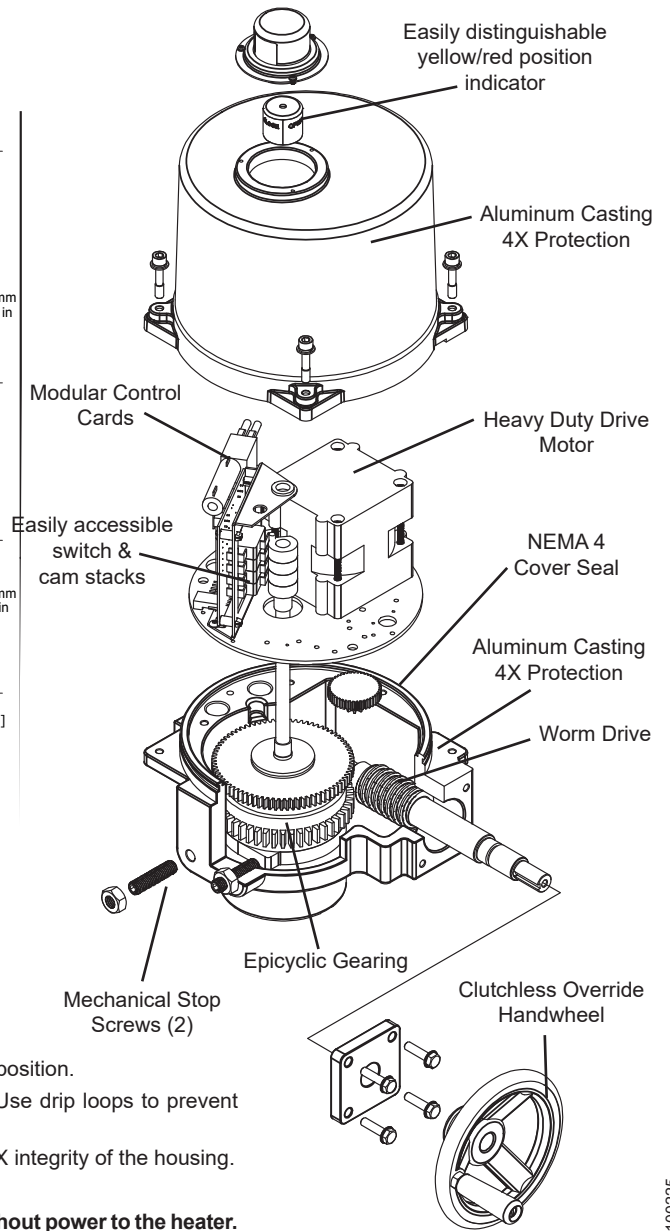
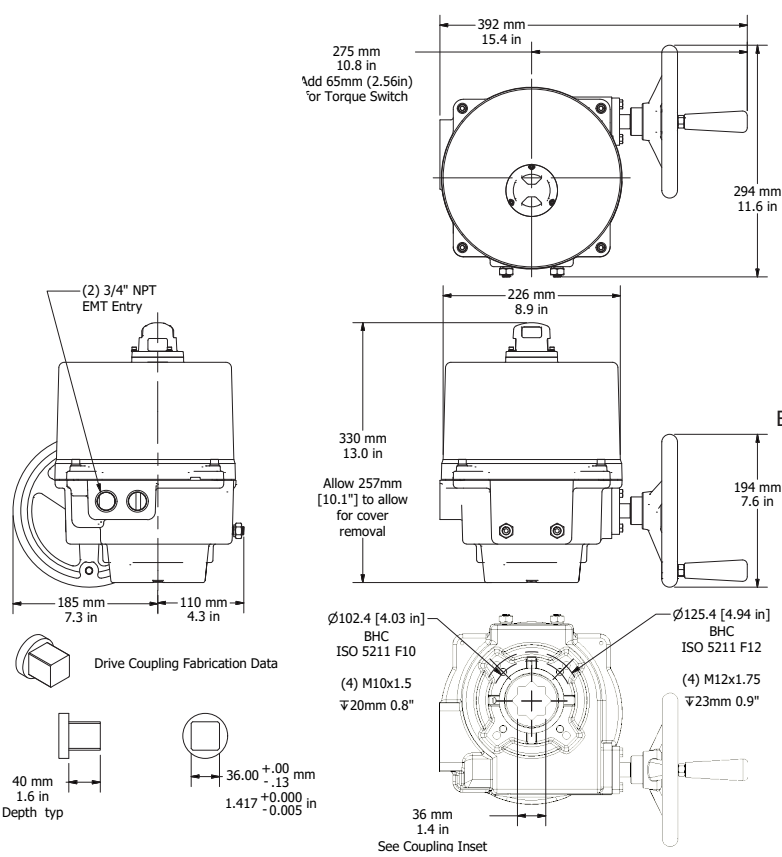

Application Notes:

1. These actuators are to be mounted ONLY between a horizontal and upright position.
2. When installing conduit, use proper techniques for entry into the actuator. Use drip loops to prevent conduit condensate from entering the actuator.
3. Both NPT conduit ports MUST use proper equipment to protect the NEMA 4X integrity of the housing.
4. The anti-condensate heater is to be used in ALL applications.
5. **Do not install or store the actuator outdoors or in humid environments without power to the heater.**
6. Use proper wire size to prevent actuator failure (see wire sizing chart).
7. Mechanical travel stops exist to prevent over-rotation for manual override only. They are not intended to stop motor driven rotation.
8. **Do not parallel wire multiple actuators together without utilizing isolation relays!** If this is your intention, please contact ProMation Engineering for a multiple actuator parallel wiring diagram.

Switch Logic Map and Switch/Cam Arrangement

Switch sequencing data is provided in the table below to show the change-of-state points during the rotation of the actuator from OPEN to CLOSED and back again. The red bar indicates when that terminal makes with it's respective common.

SW1 and SW2 are set at the factory and should NOT be changed. The INCLUDED auxiliary switches SW3 & SW4 are for terminals 7 thru 12 and those setpoints may be modified if need be. When so optioned, SW5 & SW6 auxiliary switches are initially set to function the same as auxiliary switches SW3 & SW4.

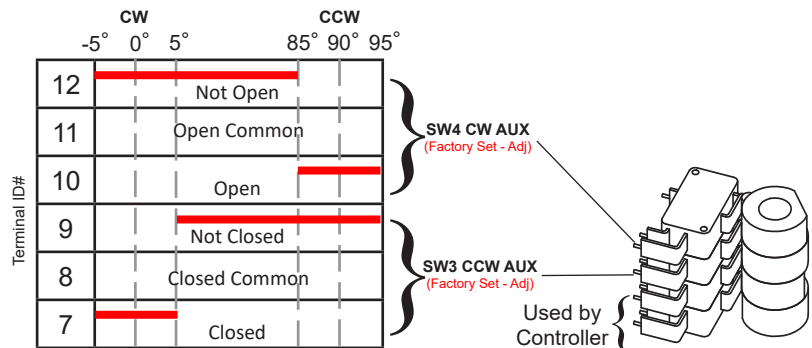

On/Off Switch/Cam arrangement shown

Wiring Diagrams for P4/5/6 Series

On/Off/Jog Control

- Field Control Device may be relay contact, Switch or Triac type.
- Pilot device 10A MAX. Auxiliary switches are rated 10A @ 250vac MAX.
- Terminals 7-12 are dry type Form C.
- Terminals accept 12-16ga solid/stranded wire.

SAMPLE DIAGRAM

Refer to the proper IOM for your actuator for the correct wiring diagram or visit www.promationei.com.

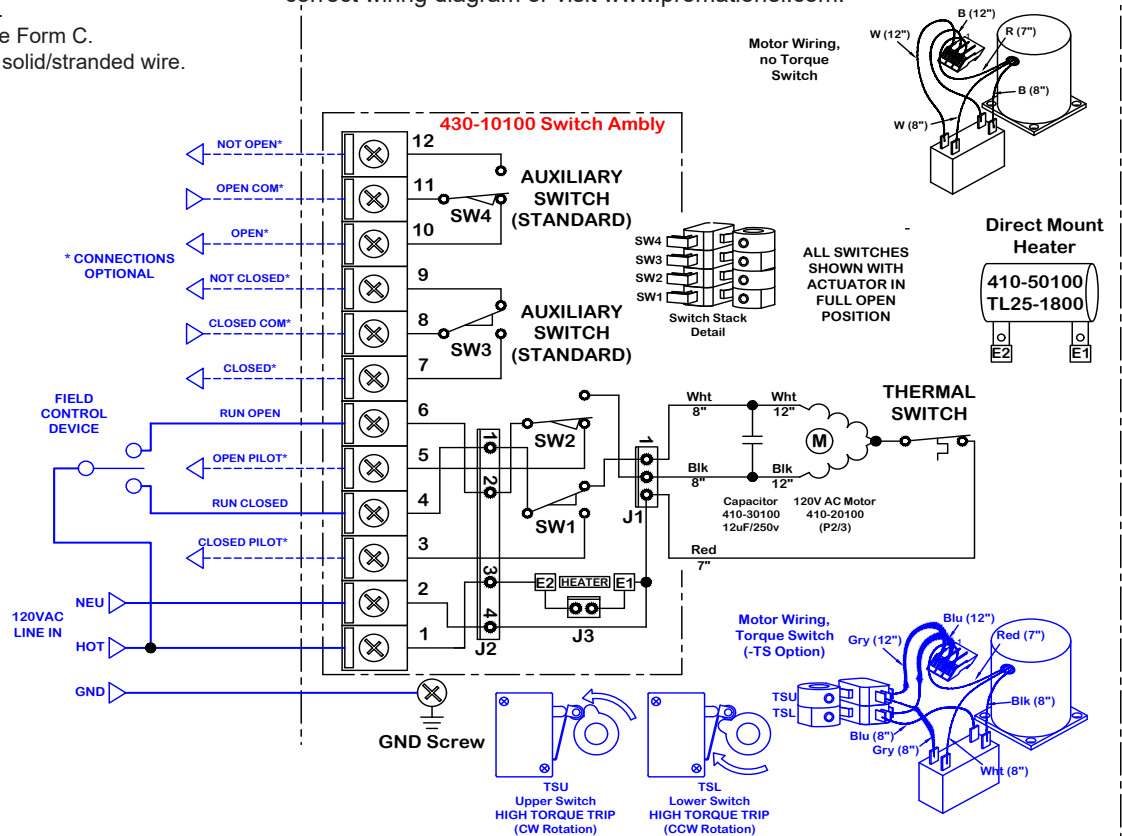

Wire Sizing Chart

Actuator	MAX distance between Actuator and Supply (feet)					
	P4		P5		P6	
Voltage	120VAC	230VAC	120VAC	230VAC	120VAC	230VAC
Amps	2.1A	1.1A	2.0A	1.0A	2.4A	1.1A
Wire Gauge						
16	618	2263	649	2489	541	2263
14	999	3655	1049	4021	874	3655
12	1528	5591	1604	6150	1337	5591

Wire sizing data is provided in the Wire Sizing Chart to assist in the selection of the proper wire size for ProMation P Series actuators using various wire sizes over distance.

Please make sure to reference the correct voltage and do not exceed the indicated length of the wire run for each model.

Proportional Control

ProMation Premium Controller:

The Premium controller offers a full array of features - such as various control and feedback signals, alphanumeric readout, several fault indicators for operational diagnostics,

extensive data logging that provides full proportional control for all industrial applications. ModBus communications are also an option on this controller.

Full Proportional Control Featuring:

- Autocalibration
- Programmable
- High resolution
- Alarm Outputs
- Data logging
- Simple User Interface
- Field Selection Friendly
- Thermal Management



Control Signal Inputs

(selectable using program menu):
0-10vdc, 1-5vdc, 2-10vdc, 4-20mA

Factory set with common isolated from ground. Ground reference is possible.

Feedback Signal Output

(Can be different than input):
0-10vdc, 1-5vdc, 2-10vdc, 4-20mA

Max Load: 250 ohms

Signal	Input Impedance	Sensitivity
0-10vdc	140k ohms	50mV
1-5vdc	250k ohms	20mV
2-10vdc	140k ohms	40mV
4-20mA	250 ohms	80µA

Auxiliary Signal Output

(programmable):
Alarm Contacts allow for signaling of 5 different fault conditions.

2 Position Control

Contacts and capability for 2 position (only) override of the actuator.

AVAILABLE OPTIONS (Factory Installed)

- Premium Proportional Controller Option. Converts 2 position to proportional control.
- Extended Duty Motor - 75% Duty Cycle.
- Single Wire Control Relay (Internal) Units operate NORMALLY CLOSED - ENERGIZE TO OPEN.
- Single Wire Control Relay (Internal) Units operate NORMALLY OPEN- ENERGIZE TO CLOSED.
- Mechanical Torque Switch Assembly. P2~P13 except P2/3 120/230PN4-AC series.
- IP68 Protection, tested to 0.7kgf/cm² for 72 hours. P2~P8 only.
- 0-45-90 degree rotation option.
- 0-90-180 degree rotation option. P2~P8 only.
- 0-180 degree rotation option. No Mid-point position is offered. (On/Off only). P2~P8 only.
- 1k ohm position feedback potentiometer.
- 5k ohm position feedback potentiometer.
- 10k ohm position feedback potentiometer.
- 4-20mA feedback generator for On/Off/Jog actuators.
- Auxiliary Switch set. Provides 3rd and 4th auxiliary switches (Form C x 2).
- Adjustable Timer, Dual Set Point Timer (Duration and Frequency) (Contact factory for application assistance).
- Proportional Control Signal override capability (OPEN OR CLOSED). P2~P13 Series only.
- Integral Thermostat for Heater Control - turns on at 32°F, turns off at 50°F.
- Cold weather auxiliary heater option. Thermostatically controlled, On 32°F, Off at 50°F, auto reset, hermetically sealed, 120/230vac On/Off/Jog type actuators. 175W Internal Heater, 2A power consumption.
- Timer function which slows actuator rotation (cycle time) using an internally mounted octal timer. (Contact factory for application assistance). P2 - P13 series only.
- Chain wheel override for applications where an actuator is mounted some distance from the floor. (Use with LCS).
- Local Control Stations (LCS) ProMation LCSs are designed to be remotely located or directly mounted to the actuator. Proportional actuators will have different options than On/Off. Available in steel, stainless, or fiberglass enclosures. (See catalog for additional Local Control Selections).
- 3 Phase models with or without Motor Control Center.
- Optional SCADA and Modbus compatability.
- Epoxy coating for increased environmental protection.
- Nylon coating for increased environmental protection.
- Stainless Steel enclosure. P1~P6 Only.

ProMation Product Line



**P Series
Non-Spring Return**

**55”lbs through
40,000”lbs.**

Quarter-Turn, with
manual Override



**PA~PD Series
Spring Return**

**445”lbs through
2300”lbs.**

Quarter-Turn, available
with or without manual
override handwheel.



**PBU Battery
Back-Up Systems**

**Provides power
sufficient to drive
P Series actuators**
Electric fail-safe option
for P Series & PL Series

SD_P213_HV VerR_100225

ProMation Engineering follows a policy of continual product updates and enhancements. Our website is the best place to obtain the latest product documentation, including the wiring diagrams for these controllers. Visit us at www.promationei.com or use the QR code below to link to the site.



**PROMATION
ENGINEERING**
Precision Actuation for Industry

16138 Flight Path Drive
Brooksville, FL 34604
Phone (352) 544-8436 Fax (352) 544-8439
email: sales@promationei.com



Use your smart phone
barcode scanner app here.